

- Features :
- Universal AC input/Full range
 - Low leakage current<0.5mA
 - Protections: Short circuit / Overload / Over voltage
 - Cooling by free air convection
 - 100% full load burn-in test
 - Fixed switching frequency at 65KHz
 - 2 years warranty



■ GTIN CODE

MW Search: <https://www.meanwell.com/serviceGTIN.aspx>



SPECIFICATION

MODEL	PT-65A			PT-65B			PT-65C			PT-65D			
OUTPUT	OUTPUT NUMBER	CH1	CH2	CH3	CH1	CH2	CH3	CH1	CH2	CH3	CH1	CH2	CH3
	DC VOLTAGE	5V	12V	-5V	5V	12V	-12V	5V	15V	-15V	5V	12V	24V
	RATED CURRENT	5.5A	2.5A	0.5A	5.5A	2.5A	0.5A	5.5A	2A	0.5A	4A	2A	1A
	CURRENT RANGE	0.4 ~ 7A	0.2 ~ 3.2A	0 ~ 0.7A	0.4 ~ 7A	0.2 ~ 3.2A	0 ~ 0.7A	0.4 ~ 7A	0.2 ~ 2.6A	0 ~ 0.7A	0.5 ~ 5A	0.2 ~ 4A	0.2 ~ 1.3A
	RATED POWER	60W			63.5W			65W			68W		
	OUTPUT POWER (max.)	Rated output power for convection; 72W with 18CFM min. Forced air											
	RIPPLE & NOISE (max.) Note.2	50mVp-p	120mVp-p	50mVp-p	50mVp-p	120mVp-p	100mVp-p	50mVp-p	120mVp-p	100mVp-p	50mVp-p	100mVp-p	200mVp-p
	VOLTAGE ADJ. RANGE	CH1:4.75 ~ 5.5V											
	VOLTAGE TOLERANCE Note.3	±4.0%	±7.0%	±5.0%	±4.0%	±7.0%	±5.0%	±4.0%	±7.0%	±5.0%	±4.0%	±6.0%	±6.0%
	LINE REGULATION	±1.0%	±2.0%	±1.0%	±1.0%	±2.0%	±1.0%	±1.0%	±2.0%	±1.0%	±1.0%	±2.0%	±3.0%
LOAD REGULATION	±3.0%	±4.0%	±1.0%	±3.0%	±4.0%	±1.0%	±3.0%	±4.0%	±1.0%	±2.0%	±5.0%	±5.0%	
SETUP, RISE TIME	800ms, 20ms at full load												
HOLD UP TIME (Typ.)	60ms at full load												
INPUT	VOLTAGE RANGE	90 ~ 264VAC			127 ~ 370VDC								
	FREQUENCY RANGE	47 ~ 440Hz											
	EFFICIENCY(Typ.)	76%			77%			77%			79%		
	AC CURRENT (Typ.)	1.5A/115VAC			0.9A/230VAC								
	INRUSH CURRENT (Typ.)	COLD START 20A/115VAC			40A/230VAC								
LEAKAGE CURRENT	<0.75mA												
PROTECTION	OVERLOAD	73 ~ 95W rated output power									74.8 ~ 98.6W rated output power		
	OVER VOLTAGE	5.75 ~ 6.75VDC on CH1 Protection type : Hiccup mode, recovers automatically after fault condition is removed.											
ENVIRONMENT	WORKING TEMP.	-10 ~ +60°C (Refer to "Derating Curve")											
	WORKING HUMIDITY	20 ~ 90% RH non-condensing											
	STORAGE TEMP., HUMIDITY	-20 ~ +85°C, 10 ~ 95% RH											
	TEMP. COEFFICIENT	±0.04%/°C (0 ~ 50°C) on +5V output											
SAFETY & EMC (Note 4)	SAFETY STANDARDS	UL62368-1, TUV BS EN/EN62368-1, EAC TP TC 004 approved											
	WITHSTAND VOLTAGE	I/P-O/P:3KVAC I/P-FG:2KVAC O/P-FG:0.5KVAC 1min.											
	ISOLATION RESISTANCE	I/P-O/P, I/P-FG, O/P-FG:100M Ohms / 500VDC / 25°C / 70% RH											
	EMC EMISSION	Compliance to BS EN/EN55032 (CISPR32) Class B, BS EN/EN61000-3-2,-3, EAC TP TC 020											
	EMC IMMUNITY	Compliance to BS EN/EN61000-4-2,3,4,5,6,8,11, BS EN/EN55035, light industry level, EAC TP TC 020											
OTHERS	MTBF	3291.3K hrs min. Telcordia SR-332 (Bellcore) ; 456.9K hrs min. MIL-HDBK-217F (25°C)											
	DIMENSION	127*76*42mm (L*W*H)											
	PACKING	0.25Kg; 54pcs/15.9Kg/1.28CUFT											
NOTE	<ol style="list-style-type: none"> 1. All parameters NOT specially mentioned are measured at 230VAC input, rated load and 25°C of ambient temperature. 2. Ripple & noise are measured at 20MHz of bandwidth by using a 12" twisted pair-wire terminated with a 0.1 μ F & 47 μ F parallel capacitor. 3. Tolerance : includes set up tolerance, line regulation and load regulation. 4. The power supply is considered a component which will be installed into a final equipment. All the EMC tests are been executed by mounting the unit on a 360mm*360mm metal plate with 1mm of thickness. The final equipment must be re-confirmed that it still meets EMC directives. For guidance on how to perform these EMC tests, please refer to "EMI testing of component power supplies." (as available on https://www.meanwell.com/Upload/PDF/EMI_statement_en.pdf) 5. Mounting holes M1 and M2 should be grounded for EMI purposes. 6. Heat Sink HS1,HS2 can not be shorted. 7. The ambient temperature derating of 3.5°C/1000m with fanless models and of 5°C/1000m with fan models for operating altitude higher than 2000m(6500ft). <p>※ Product Liability Disclaimer : For detailed information, please refer to https://www.meanwell.com/serviceDisclaimer.aspx</p>												

Mechanical Specification

(Unit: mm , tolerance ± 1 mm)

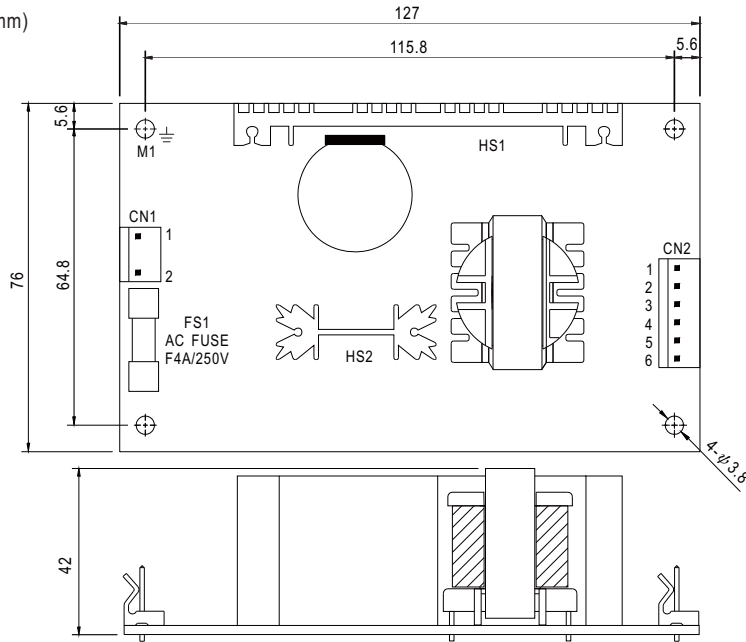

⚠ 1.HS1,HS2 cannot be shorted
2.M1 is safety ground

AC Input Connector (CN1) : Molex 5277-02 or equivalent

Pin No.	Assignment	Mating Housing	Terminal
1	AC/N	Molex 5195 or equivalent	Molex 5194 or equivalent
2	AC/L		

⊥ : Grounding Required

DC Output Connector (CN2) : Molex 5273-06 or equivalent

Pin No.	Assignment	Mating Housing	Terminal
1	V2	Molex 5195 or equivalent	Molex 5194 or equivalent
2,3	+5V		
4,5	COM		
6	V3		

※PIN2: +5V PIN3,4,5: COM only for PT-65D

Block Diagram

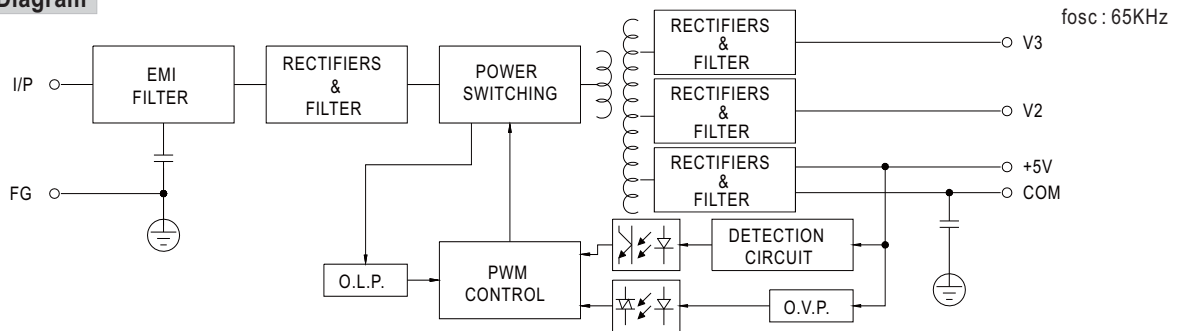

Derating Curve

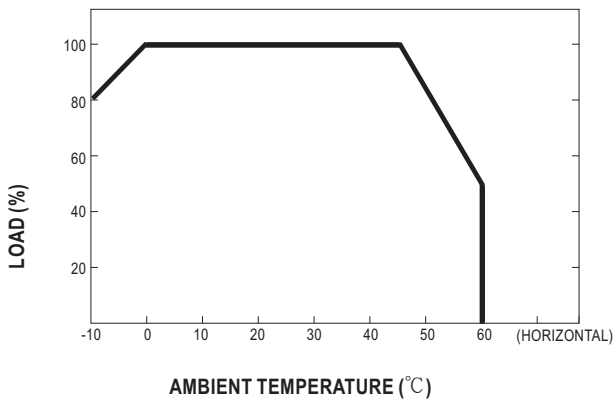

Output Derating VS Input Voltage

