

## 2A 150KHZ DC switching voltage stabilizing circuit

### Summary

LM2595 is a PWM DC-DC stabilized power converter with fixed frequency of 150KHz. It has the characteristics of 2A output current driving capability, high efficiency, low ripple, high linear regulation rate and load regulation rate. The chip adopts PWM modulation mode to adjust the linear range of duty cycle from 0 to 100%.

LM2595 has a built-in fixed frequency oscillator and frequency compensation module, which is simple to use and requires only a few external components. In addition, the chip also has built-in functions such as enabling with hysteresis function, over-temperature protection, over-current protection and stimulation over-current protection. When the secondary overcurrent protection occurs, the chip's built-in frequency reduction function reduces the working frequency from 150KHz to 50KHz.

### Characteristic

- The input voltage range is 4.5V to 40V.
- The regulated output has 3.3V, 5V, 12V and output adjustable versions, and the adjustable range of the output adjustable version is 1.23V to 37v.
- The duty ratio can be adjusted from 0% to 100%
- The minimum saturation pressure drop is 1.5V
- 150KHz fixed working frequency
- 2A Fixed current output capability
- ON-OFF hysteresis switch function
- Built-in over-temperature protection and over-current protection
- Built-in frequency compensation function
- High working efficiency, linear adjustment rate and load adjustment rate

### Application

- Simple High-Efficiency Step-Down (Buck) Regulator
- Efficient Preregulator for Linear Regulators
- On-Card Switching Regulators
- Positive-to-Negative Converter

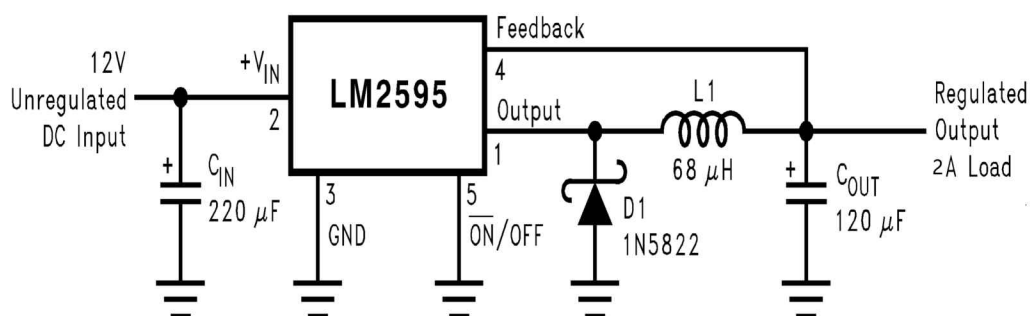

2A 150KHZ DC switching voltage stabilizing circuit

Package Types

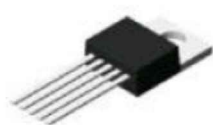

TO220-5L

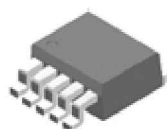

TO263-5L

Pin Assignments

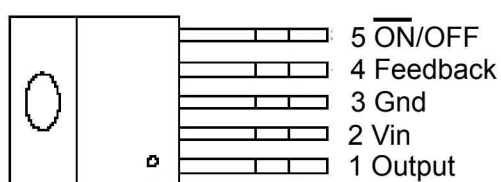

TO220-5L

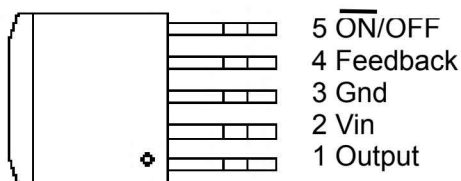

TO263-5L

Pin Descriptions

| Name     | Description                                    |
|----------|--|
| Vin      | Input supply voltage                           |
| Output   | Switching output                               |
| Gnd      | Ground   |
| Feedback | Output voltage feedback                        |
| ON/OFF   | ON/OFF shutdown<br>Active is "Low" or floating |

Pin description

| Pin number | Pin name | I/O | Functional description   |
|------------|----------|-----|--|
| 1          | OUTPUT   | O   | Output pin of power tube. The output pin of the power tube is a switch node, which supplies power to the output load.  |
| 2          | VIN      | I   | Power supply input pin. It is necessary to provide a DC power supply in the range of 4.5V~40V when working. Connect a capacitor with a large capacity in parallel between the power supply pin and the ground to eliminate power supply noise. |
| 3          | GND      | -/O | Ground pin. It is necessary to pay attention to the layout, and this pin should be placed on the path from the output point outside the Schott diode to the ground to prevent the noise caused by the switching current spike.                 |
| 4          | FEEDBACK | I/O | Voltage feedback pin. The voltage feedback terminal monitors and controls the output voltage through a resistor voltage dividing network of ten thousand units. The threshold voltage of the feedback terminal is 1.23V v.                     |
| 5          | ON_OFF   | I   | Enable the switch pin. The switch pin makes the chip work by applying a position: applying a high potential to turn off the chip. When it floats, it defaults to low potential.  |

Internal block diagram

2A 150KHZ DC switching voltage stabilizing circuit

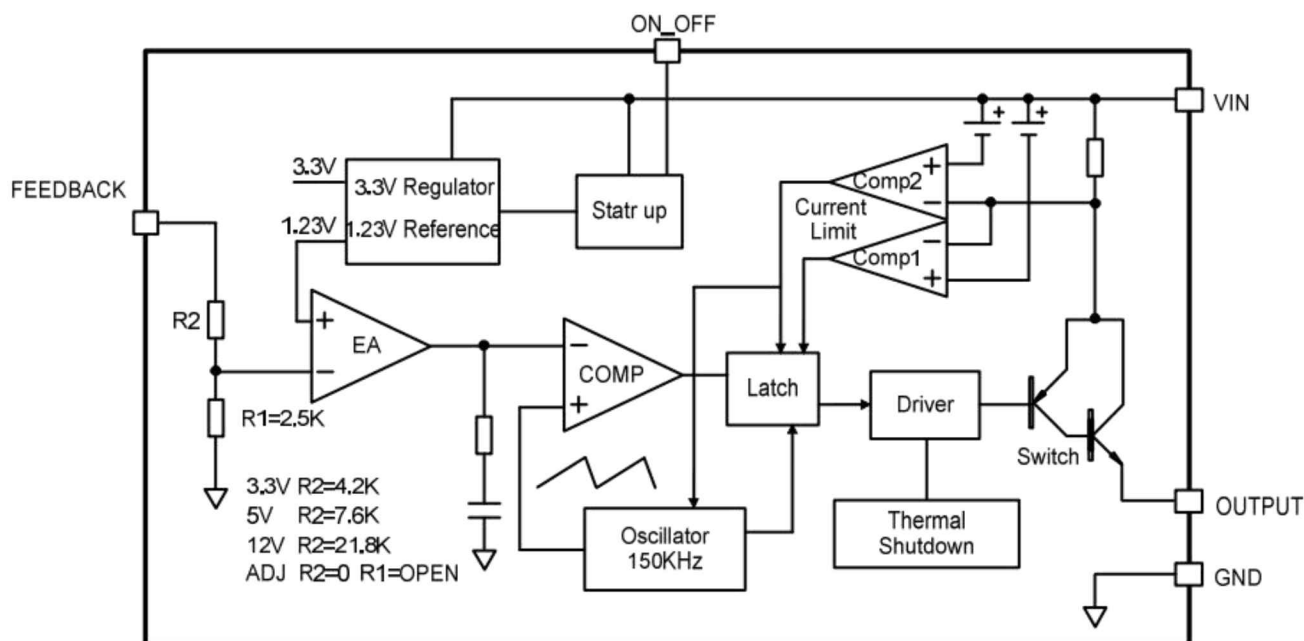

Limit parameter

| parameter                             | symbol        | range                | unit |
|---------------------------------------|---------------|----------------------|------|
| Input power supply voltage LM2595     | $V_{IN}$      | ~40                  | V    |
| Voltage feedback terminal voltage     | $V_{FB}$      | -0.3~ $V_{IN}$       | V    |
| Switching terminal voltage            | $V_{ON\_OFF}$ | -0.3~ $V_{IN}$       | V    |
| Output terminal voltage of power tube | $V_{OUTPUT}$  | -0.3~ $V_{IN}$       | V    |
| power consumption                     | $P_D$         | Internal restriction | m/W  |
| Working temperature saving            | $T_J$         | -40~125              | °C   |
| Storage temperature                   | $T_{STG}$     | -65~150              | °C   |
| Welding wire temperature              | $T_{LEAD}$    | 260                  | °C   |
| ESD capability (human discharge mode) | ESD           | 2000                 | V    |

Note 1: If the value applied to the circuit is greater than the maximum value of the parameters in the above table, it may cause permanent damage to the chip. The reliability of the chip may be affected by operating the chip continuously for several cycles under the above - mentioned limit conditions.

Recommended working conditions

| parameter                            | symbol   | range    | unit |
|--------------------------------------|----------|----------|------|
| Input voltage LM2595                 | $V_{IN}$ | 5~40     | V    |
| Operating junction temperature range | $T_J$    | -40~+125 | °C   |

**2A 150KHZ DC switching voltage stabilizing circuit**

Electrical characteristics (unless otherwise specified, the parameters shown in black font,

 $T_{amb}=25^{\circ}\text{C}$ , normal working junction temperature range  $-40^{\circ}\text{C}\sim 125^{\circ}\text{C}$ )

Electrical characteristics LM2595 -3.3

 $T_a=25^{\circ}\text{C}$ ; Unless otherwise specified.

| parameter                         | symbol    | test condition   | minimum value | typical value | maximum | unit |
|-----------------------------------|-----------|--|---------------|---------------|---------|------|
| System parameters Figure 5        |           |  |               |               |         |      |
| Output regulated value LM2595-3.3 | $V_{OUT}$ | $V_{IN}=4.75\text{V} \sim 40\text{V}$<br>$I_{LOAD}=0.2\text{A} \sim 2\text{A}$ | 3.168         | 3.3           | 3.432   | V    |
| efficiency                        | n         | $V_{IN}=12\text{V}, V_{OUT}=5\text{V}$<br>$I_{LOAD}=2\text{A}$                 |               | 73            |         | %    |

Electrical characteristics LM2595 - 5.0

 $T_a=25^{\circ}\text{C}$ ; Unless otherwise specified.

| parameter                         | symbol    | test condition  | minimum value | typical value | maximum | unit |
|-----------------------------------|-----------|---|---------------|---------------|---------|------|
| System parameters Figure 5        |           |   |               |               |         |      |
| Output regulated value LM2595-5.0 | $V_{OUT}$ | $V_{IN}=7\text{V} \sim 40\text{V}$<br>$I_{LOAD}=0.2\text{A} \sim 2\text{A}$ | 4.8           | 5             | 5.2     | V    |
| efficiency                        | n         | $V_{IN}=12\text{V}, V_{OUT}=5\text{V}$<br>$I_{LOAD}=2\text{A}$              |               | 80            |         | %    |

Electrical characteristics LM2595 -12

 $T_a=25^{\circ}\text{C}$ ; Unless otherwise specified.

| parameter                        | symbol    | test condition   | minimum value | typical value | maximum | unit |
|----------------------------------|-----------|--|---------------|---------------|---------|------|
| System parameters Figure 5       |           |  |               |               |         |      |
| Output regulated value LM2595-12 | $V_{OUT}$ | $V_{IN}=15\text{V} \sim 40\text{V}$<br>$I_{LOAD}=0.2\text{A} \sim 2\text{A}$ | 11.52         | 12            | 12.48   | V    |
| efficiency                       | n         | $V_{IN}=25\text{V}, V_{OUT}=5\text{V}$<br>$I_{LOAD}=2\text{A}$               |               | 90            |         | %    |

Electrical characteristics LM2595 -ADJ

 $T_a=25^{\circ}\text{C}$ ; Unless otherwise specified.

| parameter                         | symbol    | test condition  | minimum value | typical value | maximum | unit |
|-----------------------------------|-----------|---|---------------|---------------|---------|------|
| System parameters Figure 5        |           |   |               |               |         |      |
| Output regulated value LM2595-ADJ | $V_{OUT}$ | $V_{IN}=4.5\text{V} \sim 40\text{V}$<br>$I_{LOAD}=0.2\text{A} \sim 2\text{A}$ | 1.193         | 1.23          | 1.267   | V    |
| efficiency                        | n         | $V_{IN}=12\text{V}, V_{OUT}=3\text{V}$<br>$I_{LOAD}=2\text{A}$                |               | 73            |         | %    |

**2A 150KHZ DC switching voltage stabilizing circuit**
**DC parameters of all electrical appliances**

3.3V, 5V, ADJ version,  $V_{IN}=12V$ ; 12V version,  $V_{IN}=24V$ .  $GND = 0$ , and a  $220\mu F/50V$  capacitor is connected in parallel between  $vin$  and  $gnd$ .

$I_{OUT}=500mA, T_a=25^\circ C$ . Unless otherwise specified.

| parameter  | symbol        | test condition                             | minimum value | typical value | maximum | unit         |
|--|---------------|--|---------------|---------------|---------|--------------|
| Input working voltage  | $V_{IN}$      |  | 4.5           |               | 40      | V            |
| Standby current  | $I_{STBY}$    | $V_{ON\_OFF}=5V$                           |               | 80            | 200     | $\mu A$      |
| Static working current   | $I_Q$         | $V_{ON\_OFF}=0V,$<br>$V_{FB}=V_{IN}$       |               | 2             | 10      | mA           |
| Working frequency  | $F_{OSC}$     |  | 127           | 150           | 173     | kHz          |
| Limit current  | $I_L$         | $V_{FB}=0$                                 | 2.2           | 3             | 4.5     | A            |
| Threshold voltage of switch pin  | $V_{ON\_OFF}$ | Hight (control off)<br><br>low(control on) |               | 1.4<br>0.8    |         | V            |
| Switch pin leakage   | $I_H$         | $V_{ON\_OFF}=2.5V(ON)$                     |               | 5             | 15      | $\mu A$      |
|  | $I_L$         | $V_{ON\_OFF}=2.5V(ON)$                     |               | 0.2           | 5       | $\mu A$      |
| saturation voltage   | $V_{CE}$      | $V_{FB}=0V$<br>$L_{OUT}=3A$                |               | 1.3           | 1.5     | V            |
| Maximum duty cycle   | $D_{MAX}$     | $C_{FB}=0V$                                |               | 100           |         | %            |
| Thermal resistance coefficient (without fins)<br>TO220,TO263<br>Encapsulation) | $R_{JA}$      |  |               | 50            |         | $^\circ C/W$ |

**Functional description**

LM2595 is a voltage-drop regulated DC power converter, whose main function is to convert high-voltage DC voltage with large noise and ripple into low-voltage DC regulated output with small ripple and noise. There are four different versions of LM2595. The four versions are divided into different output regulated values, namely 3.3V, 5V, 12V and adjustable output voltage versions. On-chip provides over-temperature protection function and current limiting protection function.

**2A 150KHZ DC switching voltage stabilizing circuit**
**LM2595 series step-down regulator design program (fixed output)**

| condition          |                  |                           | Inductor (L1)   | Output capacitance (COUT)  |                          |                        |                            |
|--------------------|------------------|---------------------------|-----------------|----------------------------|--------------------------|------------------------|----------------------------|
|                    |                  |                           |                 | Through hole electrolysis  |                          | Surface mount tantalum |                            |
| Output voltage (V) | load current (A) | Maximum input voltage (V) | inductance (uh) | PanasonicHFQ Series (uf/V) | NichiconPL Series (uf/V) | AVX TPS Series (uf/V)  | Sprague 595D Series (uf/V) |
| 3.3                | 2                | 5                         | 22              | 470/25                     | 560/16                   | 330/6.3                | 390/6.3                    |
|                    |                  | 7                         | 22              | 560/35                     | 560/35                   | 330/6.3                | 390/6.3                    |
|                    |                  | 10                        | 22              | 680/35                     | 680/35                   | 330/6.3                | 390/6.3                    |
|                    | 1                | 40                        | 33              | 560/35                     | 470/35                   | 330/6.3                | 390/6.3                    |
|                    |                  | 6                         | 22              | 470/25                     | 470/35                   | 330/6.3                | 390/6.3                    |
|                    |                  | 10                        | 33              | 330/35                     | 330/35                   | 330/6.3                | 390/6.3                    |
|                    |                  | 40                        | 47              | 330/35                     | 270/50                   | 220/10                 | 330/10                     |
| 5                  | 2                |                           | 22              | 470/25                     | 560/16                   | 220/10                 | 330/10                     |
|                    |                  | 10                        | 22              | 560/25                     | 560/25                   | 220/10                 | 330/10                     |
|                    |                  | 15                        | 33              | 330/35                     | 330/35                   | 220/10                 | 330/10                     |
|                    | 1                | 40                        | 47              | 330/35                     | 270/35                   | 220/10                 | 330/10                     |
|                    |                  | 9                         | 22              | 470/25                     | 560/16                   | 220/10                 | 330/10                     |
|                    |                  | 20                        | 68              | 180/35                     | 180/35                   | 100/10                 | 270/10                     |
|                    |                  | 40                        | 68              | 180/35                     | 180/35                   | 100/10                 | 270/10                     |
| 12                 | 2                | 15                        | 22              | 470/25                     | 470/25                   | 100/16                 | 180/16                     |
|                    |                  | 18                        | 33              | 330/25                     | 330/25                   | 100/16                 | 180/16                     |
|                    |                  | 30                        | 68              | 180/25                     | 180/25                   | 100/16                 | 120/20                     |
|                    | 1                | 40                        | 68              | 180/35                     | 180/25                   | 100/16                 | 120/20                     |
|                    |                  | 15                        | 33              | 330/25                     | 330/25                   | 100/16                 | 180/16                     |
|                    |                  | 20                        | 68              | 180/25                     | 180/25                   | 100/16                 | 120/20                     |
|                    |                  | 40                        | 150             | 82/25                      | 82/25                    | 68/20                  | 68/25                      |

**2A 150KHZ DC switching voltage stabilizing circuit**
**LM2595 series step-down regulator design program (adjustable output)**

| Output voltage (V) | Through hole output electrolysis |                          |                         | Surface mount output capacitor |                            |                         |
|--------------------|----------------------------------|--------------------------|-------------------------|--------------------------------|----------------------------|-------------------------|
|                    | Panasonic HFQ Series (uf/V)      | NichiconPL Series (uf/V) | Feedforward capacitance | AVX TPS Series (uf/V)          | Sprague 595D Series (uf/V) | Feedforward capacitance |
| 2                  | 820/35                           | 820/35                   | 33nf                    | 330/6.3                        | 470/4                      | 33nf                    |
| 4                  | 560/35                           | 470/35                   | 10nf                    | 330/6.3                        | 390/6.3                    | 10nf                    |
| 6                  | 470/25                           | 470/35                   | 3.3nf                   | 220/10                         | 330/10                     | 3.3nf                   |
| 9                  | 330/25                           | 330/25                   | 1.5nf                   | 100/16                         | 180/16                     | 1.5nf                   |
| 12                 | 330/25                           | 330/25                   | 1nf                     | 100/16                         | 180/16                     | 1nf                     |
| 15                 | 220/25                           | 220/35                   | 680pf                   | 68/20                          | 120/20                     | 680pf                   |
| 24                 | 220/35                           | 150/35                   | 560pf                   | 33/25                          | 33/25                      | 220pf                   |
| 28                 | 100/50                           | 100/50                   | 390pf                   | 10/35                          | 15/50                      | 220pf                   |

**Schottky diode selection table**

| present | Surface mounting | Through hole installation | VR (same as the maximum input voltage of the system) |        |        |        |        |
|---------|------------------|---------------------------|--|--------|--------|--------|--------|
|         |                  |                           | 20V  | 30V    | 40V    | 50V    | 60V    |
| 1A      |                  | √                         | 1N5817   | 1N5818 | 1N5819 |        |        |
| 3A      |                  | √                         | 1N5820   | 1N5821 | 1N5822 |        |        |
|         |                  | √                         | MBR320   | MBR330 | MBR340 | MBR350 | MBR360 |
|         | √                |                           | SK32   | SK33   | SK34   | SK35   | SK36   |
|         | √                |                           |  | 30WQ03 | 30WQ04 | 30WQ05 |        |
|         |                  | √                         |  | 31DQ03 | 31DQ04 | 31DQ05 |        |
|         |                  | √                         |  | SR302  | SR303  | SR304  | SR305  |

2A 150KHZ DC switching voltage stabilizing circuit

Typical application circuit diagram

3.3V output regulated version

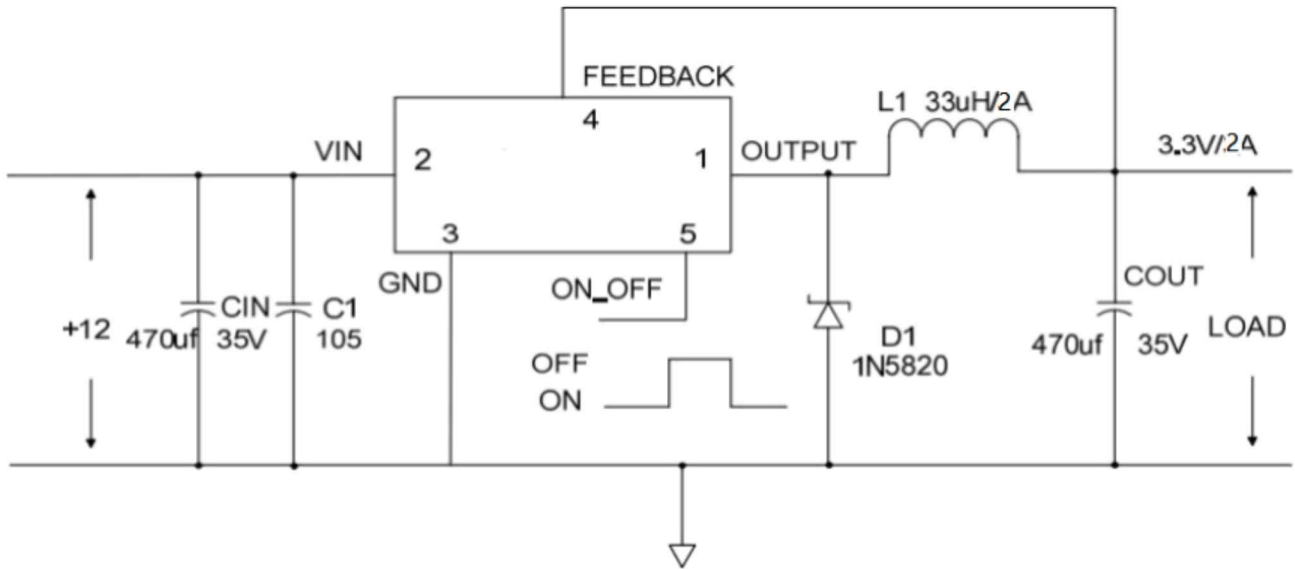

5.0V output regulated version

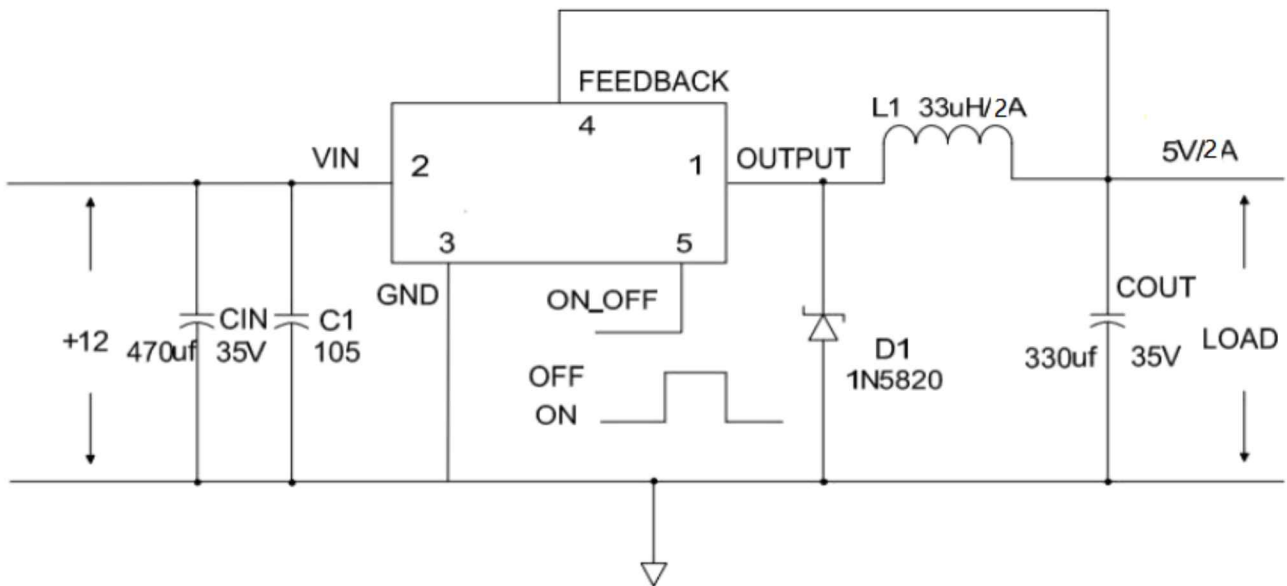

2A 150KHZ DC switching voltage stabilizing circuit

12V output regulated version

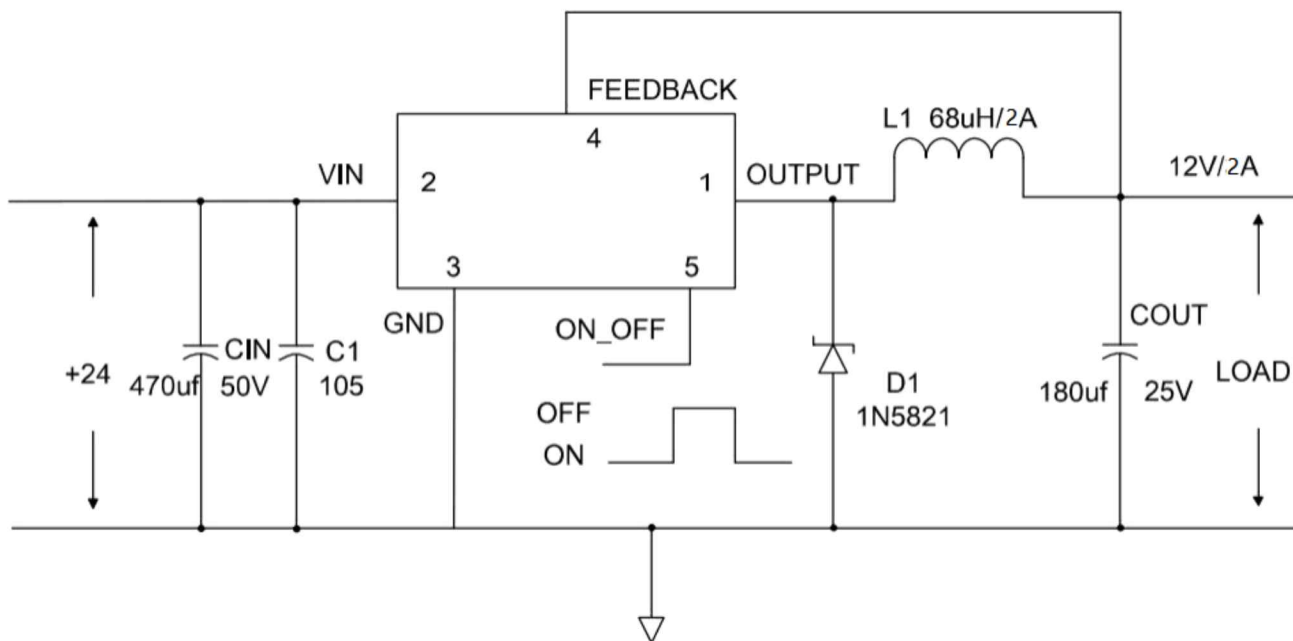

Output adjustable version

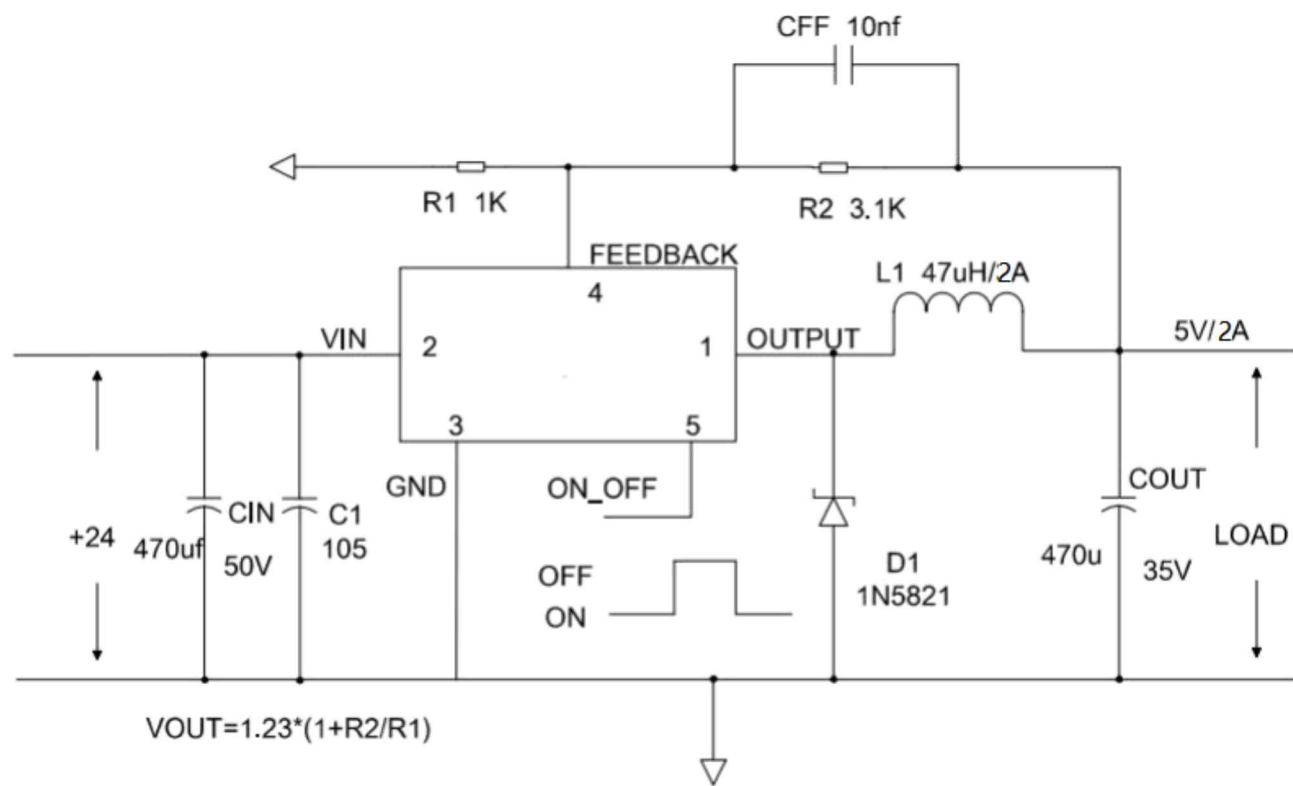

2A 150KHZ DC switching voltage stabilizing circuit

Package external dimension

TO263-5

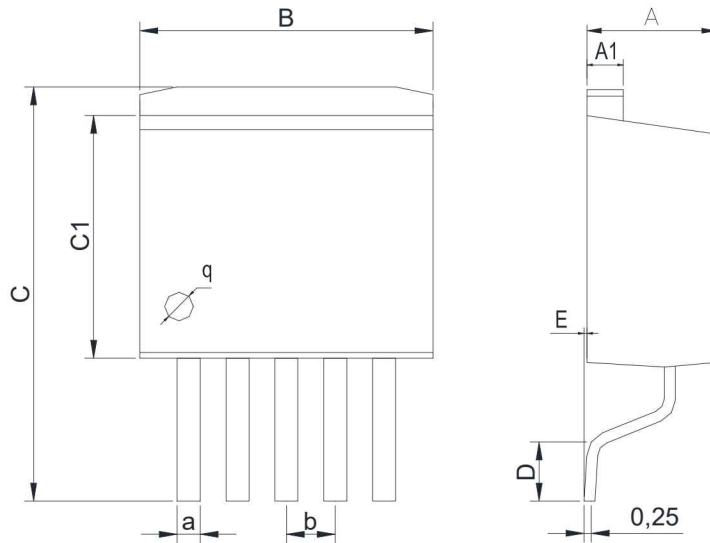

| Dimensions In Millimeters(TO263-5) |      |      |      |      |      |      |      |      |         |
|------------------------------------|------|------|------|------|------|------|------|------|---------|
| Symbol:                            | A    | A1   | B    | C    | C1   | D    | E    | a    | b       |
| Min:                               | 4.45 | 1.22 | 10   | 13.7 | 8.40 | 1.90 | 0    | 0.71 | 1.70BSC |
| Max:                               | 4.62 | 1.32 | 10.4 | 14.6 | 8.90 | 2.10 | 0.20 | 0.97 |         |

TO220-5

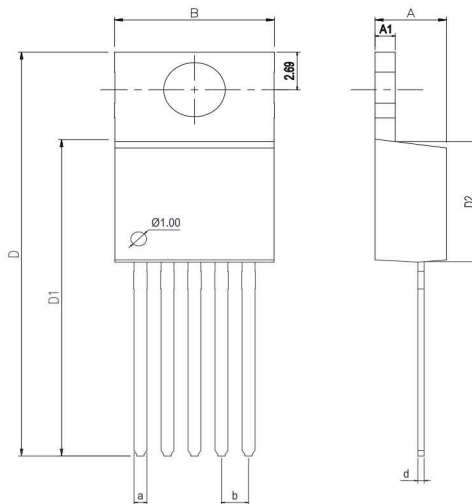

| Dimensions In Millimeters(TO220-5) |      |      |      |      |      |      |      |      |         |
|------------------------------------|------|------|------|------|------|------|------|------|---------|
| Symbol:                            | A    | A1   | B    | D    | D1   | D2   | a    | d    | b       |
| Min:                               | 4.52 | 1.25 | 10   | 28.6 | 22.4 | 8.69 | 1.68 | 0.33 | 1.70BSC |
| Max:                               | 4.62 | 1.29 | 10.3 | 28.8 | 22.6 | 8.79 | 1.77 | 0.42 |         |

**Ordering information**

| Order code      | Package | Baseqty | Deliverymode  |
|-----------------|---------|---------|---------------|
| UMW LM2595S-3.3 | TO-263  | 500     | Tape and reel |
| UMW LM2595S-5.0 | TO-263  | 500     | Tape and reel |
| UMW LM2595S-12  | TO-263  | 500     | Tape and reel |
| UMW LM2595S-ADJ | TO-263  | 500     | Tape and reel |
| UMW LM2595T-3.3 | TO-220  | 1000    | Tube and box  |
| UMW LM2595T-5.0 | TO-220  | 1000    | Tube and box  |
| UMW LM2595T-12  | TO-220  | 1000    | Tube and box  |
| UMW LM2595T-ADJ | TO-220  | 1000    | Tube and box  |