

1 Megabit (128K x8) Page-Mode EEPROM

SST29EE010 / SST29LE010 / SST29VE010



Data Sheet

FEATURES:

- **Single Voltage Read and Write Operations**
 - 5.0V-only for the SST29EE010
 - 3.0-3.6V for the SST29LE010
 - 2.7-3.6V for the SST29VE010
- **Superior Reliability**
 - Endurance: 100,000 Cycles (typical)
 - Greater than 100 years Data Retention
- **Low Power Consumption**
 - Active Current: 20 mA (typical) for 5V and 10 mA (typical) for 3.0/2.7V
 - Standby Current: 10 μ A (typical)
- **Fast Page-Write Operation**
 - 128 Bytes per Page, 1024 Pages
 - Page-Write Cycle: 5 ms (typical)
 - Complete Memory Rewrite: 5 sec (typical)
 - Effective Byte-Write Cycle Time: 39 μ s (typical)
- **Fast Read Access Time**
 - 5.0V-only operation: 90 and 120 ns
 - 3.0-3.6V operation: 150 and 200 ns
 - 2.7-3.6V operation: 200 and 250 ns
- **Latched Address and Data**
- **Automatic Write Timing**
 - Internal V_{PP} Generation
- **End of Write Detection**
 - Toggle Bit
 - Data# Polling
- **Hardware and Software Data Protection**
- **TTL I/O Compatibility**
- **JEDEC Standard**
 - Flash EEPROM Pinouts and command sets
- **Packages Available**
 - 32 Pin PDIP
 - 32-Pin PLCC
 - 32-Pin TSOP (8mm x 20mm, 8mm x 14mm)

PRODUCT DESCRIPTION

The SST29EE010/29LE010/29VE010 are 128K x8 CMOS Page-Write EEPROMs manufactured with SST's proprietary, high performance CMOS SuperFlash technology. The split-gate cell design and thick oxide tunneling injector attain better reliability and manufacturability compared with alternate approaches. The SST29EE010/29LE010/29VE010 write with a single power supply. Internal Erase/Program is transparent to the user. The SST29EE010/29LE010/29VE010 conform to JEDEC standard pinouts for byte-wide memories.

Featuring high performance Page-Write, the SST29EE010/29LE010/29VE010 provide a typical Byte-Write time of 39 μ sec. The entire memory, i.e., 128 KBytes, can be written page-by-page in as little as 5 seconds, when using interface features such as Toggle Bit or Data# Polling to indicate the completion of a Write cycle. To protect against inadvertent write, the SST29EE010/29LE010/29VE010 have on-chip hardware and Software Data Protection schemes. Designed, manufactured, and tested for a wide spectrum of applications, the SST29EE010/29LE010/29VE010 are offered with a guaranteed Page-Write endurance of 10^4 cycles. Data retention is rated at greater than 100 years.

The SST29EE010/29LE010/29VE010 are suited for applications that require convenient and economical updating of program, configuration, or data memory. For all

system applications, the SST29EE010/29LE010/29VE010 significantly improve performance and reliability, while lowering power consumption. The SST29EE010/29LE010/29VE010 improve flexibility while lowering the cost for program, data, and configuration storage applications.

To meet high density, surface mount requirements, the SST29EE010/29LE010/29VE010 are offered in 32-pin TSOP (8mm x 20mm and 8mm x 14mm) and 32-lead PLCC packages. A 600-mil, 32-pin PDIP package is also available. See Figures 1 and 2 for pinouts.

Device Operation

The SST Page-Mode EEPROM offers in-circuit electrical write capability. The SST29EE010/29LE010/29VE010 does not require separate Erase and Program operations. The internally timed write cycle executes both erase and program transparently to the user. The SST29EE010/29LE010/29VE010 have industry standard optional Software Data Protection, which SST recommends always to be enabled. The SST29EE010/29LE010/29VE010 are compatible with industry standard EEPROM pinouts and functionality.

Read

The Read operations of the SST29EE010/29LE010/29VE010 are controlled by CE# and OE#, both have to be low for the system to obtain data from the outputs. CE# is used for device selection. When CE# is high, the



chip is deselected and only standby power is consumed. OE# is the output control and is used to gate data from the output pins. The data bus is in high impedance state when either CE# or OE# is high. Refer to the read cycle timing diagram for further details (Figure 3).

Write

The Page-Write to the SST29EE010/29LE010/29VE010 should always use the JEDEC Standard Software Data Protection (SDP) three-byte command sequence. The SST29EE010/29LE010/29VE010 contain the optional JEDEC approved Software Data Protection scheme. SST recommends that SDP always be enabled, thus, the description of the Write operations will be given using the SDP enabled format. **The three-byte SDP Enable and SDP Write commands are identical; therefore, any time a SDP Write command is issued, Software Data Protection is automatically assured.** The first time the three-byte SDP command is given, the device becomes SDP enabled. Subsequent issuance of the same command bypasses the data protection for the page being written. At the end of the desired Page-Write, the entire device remains protected. For additional descriptions, please see the application notes on “The Proper Use of JEDEC Standard Software Data Protection” and “Protecting Against Unintentional Writes When Using Single Power Supply Flash Memories” in this data book.

The Write operation consists of three steps. Step 1 is the three-byte load sequence for Software Data Protection. Step 2 is the byte-load cycle to a page buffer of the SST29EE010/29LE010/29VE010. Steps 1 and 2 use the same timing for both operations. Step 3 is an internally controlled write cycle for writing the data loaded in the page buffer into the memory array for nonvolatile storage. During both the SDP three-byte load sequence and the byte-load cycle, the addresses are latched by the falling edge of either CE# or WE#, whichever occurs last. The data is latched by the rising edge of either CE# or WE#, whichever occurs first. The internal write cycle is initiated by the T_{BLCO} timer after the rising edge of WE# or CE#, whichever occurs first. The Write cycle, once initiated, will continue to completion, typically within 5 ms. See Figures 4 and 5 for WE# and CE# controlled Page-Write cycle timing diagrams and Figures 14 and 16 for flowcharts.

The Write operation has three functional cycles: the Software Data Protection load sequence, the page load cycle, and the internal write cycle. The Software Data Protection consists of a specific three-byte load sequence that allows writing to the selected page and will leave the SST29EE010/29LE010/29VE010 protected at

the end of the Page-Write. The page load cycle consists of loading 1 to 128 bytes of data into the page buffer. The internal write cycle consists of the T_{BLCO} time-out and the write timer operation. During the Write operation, the only valid reads are Data# Polling and Toggle Bit.

The Page-Write operation allows the loading of up to 128 bytes of data into the page buffer of the SST29EE010/29LE010/29VE010 before the initiation of the internal write cycle. During the internal write cycle, all the data in the page buffer is written simultaneously into the memory array. Hence, the Page-Write feature of SST29EE010/29LE010/29VE010 allow the entire memory to be written in as little as 5 seconds. During the internal write cycle, the host is free to perform additional tasks, such as to fetch data from other locations in the system to set up the write to the next page. In each Page-Write operation, all the bytes that are loaded into the page buffer must have the same page address, i.e. A₇ through A₁₆. Any byte not loaded with user data will be written to FF.

See Figures 4 and 5 for the Page-Write cycle timing diagrams. If after the completion of the three-byte SDP load sequence or the initial byte-load cycle, the host loads a second byte into the page buffer within a byte-load cycle time (T_{BLC}) of 100 μs, the SST29EE010/29LE010/29VE010 will stay in the page load cycle. Additional bytes are then loaded consecutively. The page load cycle will be terminated if no additional byte is loaded into the page buffer within 200 μs (T_{BLCO}) from the last byte-load cycle, i.e., no subsequent WE# or CE# high-to-low transition after the last rising edge of WE# or CE#. Data in the page buffer can be changed by a subsequent byte-load cycle. The page load period can continue indefinitely, as long as the host continues to load the device within the byte-load cycle time of 100 μs. The page to be loaded is determined by the page address of the last byte loaded.

Software Chip-Erase

The SST29EE010/29LE010/29VE010 provide a Chip-Erase operation, which allows the user to simultaneously clear the entire memory array to the “1” state. This is useful when the entire device must be quickly erased.

The Software Chip-Erase operation is initiated by using a specific six-byte load sequence. After the load sequence, the device enters into an internally timed cycle similar to the Write cycle. During the Erase operation, the only valid read is Toggle Bit. See Table 4 for the load sequence, Figure 9 for timing diagram, and Figure 18 for the flowchart.



1 Megabit Page-Mode EEPROM

SST29EE010 / SST29LE010 / SST29VE010

Write Operation Status Detection

The SST29EE010/29LE010/29VE010 provide two software means to detect the completion of a Write cycle, in order to optimize the system write cycle time. The software detection includes two status bits: Data# Polling (DQ₇) and Toggle Bit (DQ₆). The end of write detection mode is enabled after the rising WE# or CE# whichever occurs first, which initiates the internal write cycle.

The actual completion of the nonvolatile write is asynchronous with the system; therefore, either a Data# Polling or Toggle Bit read may be simultaneous with the completion of the Write cycle. If this occurs, the system may possibly get an erroneous result, i.e., valid data may appear to conflict with either DQ₇ or DQ₆. In order to prevent spurious rejection, if an erroneous result occurs, the software routine should include a loop to read the accessed location an additional two (2) times. If both reads are valid, then the device has completed the Write cycle, otherwise the rejection is valid.

Data# Polling (DQ₇)

When the SST29EE010/29LE010/29VE010 are in the internal write cycle, any attempt to read DQ₇ of the last byte loaded during the byte-load cycle will receive the complement of the true data. Once the Write cycle is completed, DQ₇ will show true data. The device is then ready for the next operation. See Figure 6 for Data# Polling timing diagram and Figure 15 for a flowchart.

Toggle Bit (DQ₆)

During the internal write cycle, any consecutive attempts to read DQ₆ will produce alternating 0's and 1's, i.e. toggling between 0 and 1. When the Write cycle is completed, the toggling will stop. The device is then ready for the next operation. See Figure 7 for Toggle Bit timing diagram and Figure 15 for a flowchart. The initial read of the Toggle Bit will typically be a "1".

Data Protection

The SST29EE010/29LE010/29VE010 provide both hardware and software features to protect nonvolatile data from inadvertent writes.

Hardware Data Protection

Noise/Glitch Protection: A WE# or CE# pulse of less than 5 ns will not initiate a Write cycle.

V_{CC} Power Up/Down Detection: The Write operation is inhibited when V_{CC} is less than 2.5V.

Write Inhibit Mode: Forcing OE# low, CE# high, or WE# high will inhibit the Write operation. This prevents inadvertent writes during power-up or power-down.

Software Data Protection (SDP)

The SST29EE010/29LE010/29VE010 provide the JEDEC approved optional Software Data Protection scheme for all data alteration operations, i.e., Write and Chip-Erase. With this scheme, any Write operation requires the inclusion of a series of three byte-load operations to precede the data loading operation. The three byte-load sequence is used to initiate the Write cycle, providing optimal protection from inadvertent write operations, e.g., during the system power-up or power-down. The SST29EE010/29LE010/29VE010 are shipped with the Software Data Protection disabled.

The software protection scheme can be enabled by applying a three-byte sequence to the device, during a page-load cycle (Figures 4 and 5). The device will then be automatically set into the data protect mode. Any subsequent Write operation will require the preceding three-byte sequence. See Table 4 for the specific software command codes and Figures 4 and 5 for the timing diagrams. To set the device into the unprotected mode, a six-byte sequence is required. See Table 4 for the specific codes and Figure 8 for the timing diagram. If a write is attempted while SDP is enabled the device will be in a non-accessible state for ~ 300 μs. SST recommends Software Data Protection always be enabled. See Figure 16 for flowcharts.

The SST29EE010/29LE010/29VE010 Software Data Protection is a global command, protecting (or unprotecting) all pages in the entire memory array once enabled (or disabled). Therefore using SDP for a single Page-Write will enable SDP for the entire array. Single pages by themselves cannot be SDP enabled or disabled.



1 Megabit Page-Mode EEPROM SST29EE010/SST29LE010/SST29VE010

Single power supply reprogrammable nonvolatile memories may be unintentionally altered. SST strongly recommends that Software Data Protection (SDP) always be enabled. The SST29EE010/29LE010/29VE010 should be programmed using the SDP command sequence. SST recommends the SDP Disable Command Sequence not be issued to the device prior to writing.

Please refer to the following Application Notes located at the back of this databook for more information on using SDP:

- Protecting Against Unintentional Writes When Using Single Power Supply Flash Memories
- The Proper Use of JEDEC Standard Software Data Protection

Product Identification

The product identification mode identifies the device as the SST29EE010/29LE010/29VE010 and manufacturer as SST. This mode may be accessed by hardware or software operations. The hardware operation is typically used by a programmer to identify the correct algorithm for the SST29EE010/29LE010/29VE010. Users may wish to use the software product identification operation to identify the part (i.e. using the device code) when using

multiple manufacturers in the same socket. For details, see Table 3 for hardware operation or Table 4 for software operation, Figure 10 for the software ID entry and read timing diagram and Figure 17 for the ID entry command sequence flowchart. The manufacturer and device codes are the same for both operations.

Product Identification Mode Exit

TABLE 1: PRODUCT IDENTIFICATION TABLE

	Byte	Data
Manufacturer's ID	0000 H	BF H
SST29EE010 Device ID	0001 H	07 H
SST29LE010 Device ID	0001 H	08 H
SST29VE010 Device ID	0001 H	08 H

304PGMT1.2

In order to return to the standard read mode, the Software Product Identification mode must be exited. Exiting is accomplished by issuing the Software ID Exit (reset) operation, which returns the device to the Read operation. The Reset operation may also be used to reset the device to the Read mode after an inadvertent transient condition that apparently causes the device to behave abnormally, e.g. not read correctly. See Table 4 for software command codes, Figure 11 for timing waveform and Figure 17 for a flowchart.

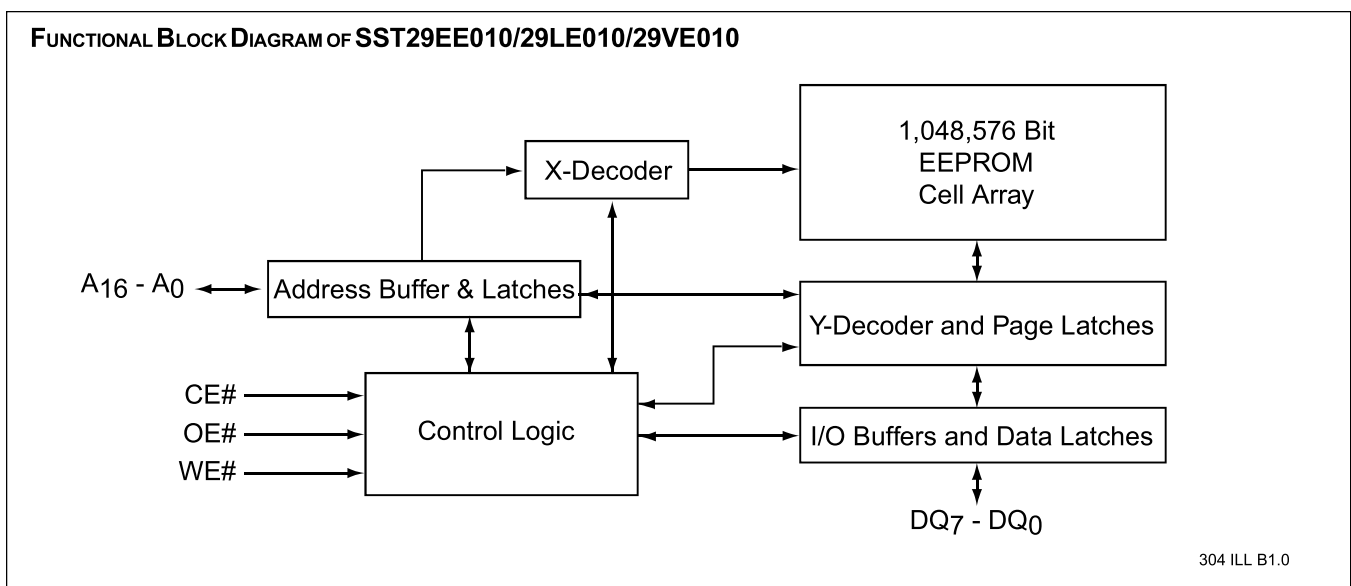



1 Megabit Page-Mode EEPROM

SST29EE010 / SST29LE010 / SST29VE010

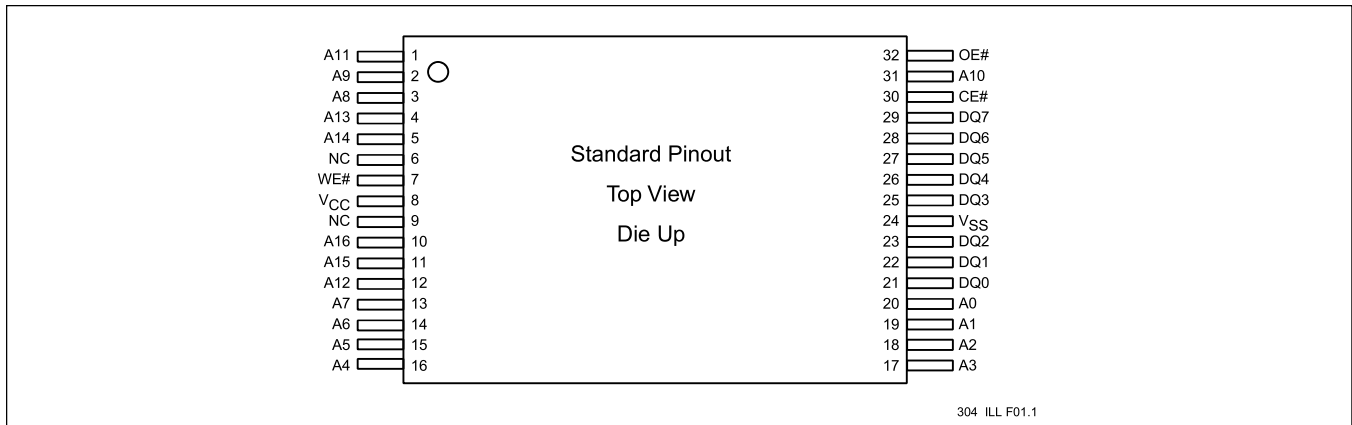

FIGURE 1: PIN ASSIGNMENTS FOR 32-PIN TSOP

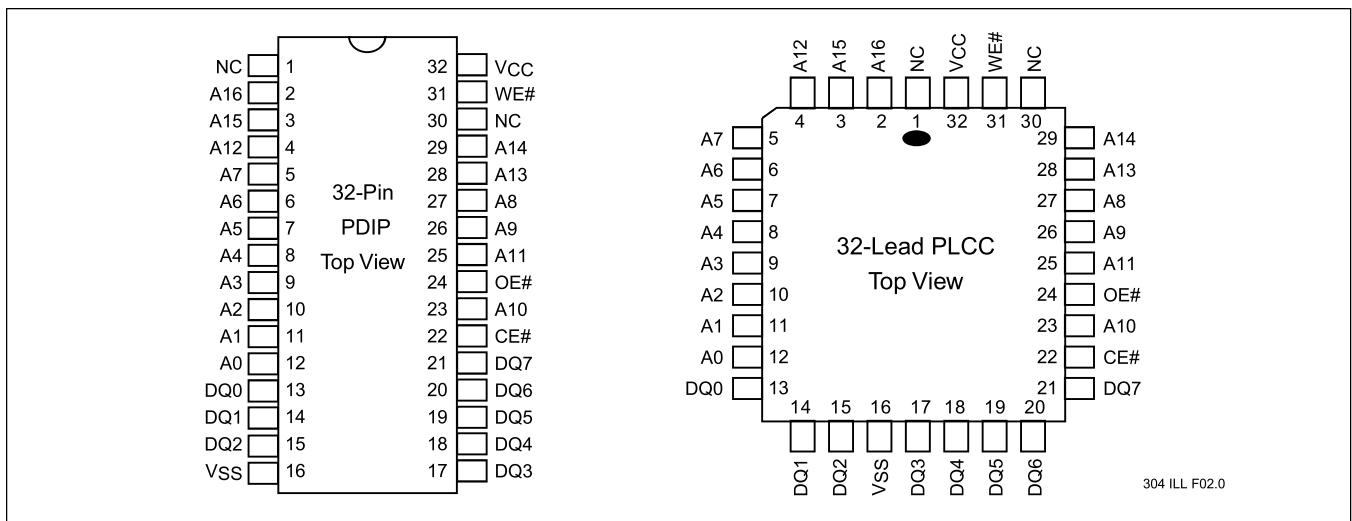

FIGURE 2: PIN ASSIGNMENTS FOR 32-PIN PLASTIC DIPs AND 32-LEAD PLCCs

TABLE 2: PIN DESCRIPTION

Symbol	Pin Name	Functions
A ₁₆ -A ₇	Row Address Inputs	To provide memory addresses. Row addresses define a page for a Write cycle.
A ₆ -A ₀	Column Address Inputs	Column Addresses are toggled to load page data.
DQ ₇ -DQ ₀	Data Input/output	To output data during Read cycles and receive input data during Write cycles. Data is internally latched during a Write cycle. The outputs are in tri-state when OE# or CE# is high.
CE#	Chip Enable	To activate the device when CE# is low.
OE#	Output Enable	To gate the data output buffers.
WE#	Write Enable	To control the Write operations
V _{cc}	Power Supply	To provide 5-volt supply ($\pm 10\%$) for the SST29EE010, 3-volt supply (3.0-3.6V) for the SST29LE010 and 2.7-volt supply (2.7-3.6V) for the SST29VE010
V _{ss}	Ground	
NC	No Connection	Unconnected pins.



1 Megabit Page-Mode EEPROM

SST29EE010/SST29LE010/SST29VE010

TABLE 3: OPERATION MODES SELECTION

Mode	CE#	OE#	WE#	DQ	Address
Read	V _{IL}	V _{IL}	V _{IH}	D _{OUT}	A _{IN}
Page-Write	V _{IL}	V _{IH}	V _{IL}	D _{IN}	A _{IN}
Standby	V _{IH}	X	X	High Z	X
Write Inhibit	X	V _{IL}	X	High Z/ D _{OUT}	X
Write Inhibit	X	X	V _{IH}	High Z/ D _{OUT}	X
Software Chip-Erase	V _{IL}	V _{IH}	V _{IL}	D _{IN}	A _{IN} , See Table 4
Product Identification					
Hardware Mode	V _{IL}	V _{IL}	V _{IH}	Manufacturer ID (BF) Device ID (see notes)	A ₁₆ - A ₁ = V _{IL} , A ₉ = V _H , A ₀ = V _{IL} A ₁₆ - A ₁ = V _{IL} , A ₉ = V _H , A ₀ = V _{IH}
Software Mode	V _{IL}	V _{IH}	V _{IL}		See Table 4
SDP Enable Mode	V _{IL}	V _{IH}	V _{IL}		See Table 4
SDP Disable Mode	V _{IL}	V _{IH}	V _{IL}		See Table 4

304 PGM T3.0

TABLE 4: SOFTWARE COMMAND CODES

Command Sequence	1st Bus Write Cycle		2nd Bus Write Cycle		3rd Bus Write Cycle		4th Bus Write Cycle		5th Bus Write Cycle		6th Bus Write Cycle	
	Addr ⁽¹⁾	Data	Addr ⁽¹⁾	Data	Addr ⁽¹⁾	Data	Addr ⁽¹⁾	Data	Addr ⁽¹⁾	Data	Addr ⁽¹⁾	Data
Software Data Protect Enable & Page-Write	5555H	AAH	2AAAH	55H	5555H	A0H	Addr ⁽²⁾	Data				
Software Data Protect Disable	5555H	AAH	2AAAH	55H	5555H	80H	5555H	AAH	2AAAH	55H	5555H	20H
Software Chip-Erase	5555H	AAH	2AAAH	55H	5555H	80H	5555H	AAH	2AAAH	55H	5555H	10H
Software ID Entry	5555H	AAH	2AAAH	55H	5555H	90H						
Software ID Exit	5555H	AAH	2AAAH	55H	5555H	F0H						
Alternate Software ID Entry ⁽³⁾	5555H	AAH	2AAAH	55H	5555H	80H	5555H	AAH	2AAAH	55H	5555H	60H

304 PGM T4.1

- Notes:**
- (1) Address format A₁₄-A₀ (Hex), Addresses A₁₅ and A₁₆ are a "Don't Care".
 - (2) Page-Write consists of loading up to 128 Bytes (A₆ - A₀).
 - (3) Alternate six-byte software Product-ID Command Code
 - (4) The software Chip-Erase function is not supported by the industrial temperature part. Please contact SST, if you require this function for an industrial temperature part.

Notes for Software Product ID Command Code:

1. With A₁₄-A₁=0; SST Manufacturer ID = BFH, is read with A₀ = 0,
SST29EE010 Device ID = 07H, is read with A₀ = 1.
SST29LE010/29VE010 Device ID = 08H, is read with A₀ = 1.
2. The device does not remain in Software Product ID Mode if powered down.
3. This device supports both the JEDEC standard three-byte command code sequence and SST's original six-byte command code sequence. For new designs, SST recommends the three-byte command code sequence be used.



1 Megabit Page-Mode EEPROM

SST29EE010 / SST29LE010 / SST29VE010

Absolute Maximum Stress Ratings (Applied conditions greater than those listed under “Absolute Maximum Stress Ratings” may cause permanent damage to the device. This is a stress rating only and functional operation of the device at these conditions or conditions greater than those defined in the operational sections of this data sheet is not implied. Exposure to absolute maximum stress rating conditions may affect device reliability.)

Temperature Under Bias	-55°C to +125°C
Storage Temperature	-65°C to +150°C
D. C. Voltage on Any Pin to Ground Potential	-0.5V to V _{CC} + 0.5V
Transient Voltage (<20 ns) on Any Pin to Ground Potential	-1.0V to V _{CC} + 1.0V
Voltage on A ₉ Pin to Ground Potential	-0.5V to 14.0V
Package Power Dissipation Capability (Ta = 25°C)	1.0W
Through Hole Lead Soldering Temperature (10 Seconds)	300°C
Surface Mount Lead Soldering Temperature (3 Seconds)	240°C
Output Short Circuit Current ⁽¹⁾	100 mA

Note: ⁽¹⁾ Outputs shorted for no more than one second. No more than one output shorted at a time.

SST29EE010 OPERATING RANGE

Range	Ambient Temp	V _{CC}
Commercial	0°C to +70°C	5V±10%
Industrial	-40°C to +85°C	5V±10%

AC CONDITIONS OF TEST

Input Rise/Fall Time	10 ns
Output Load	1 TTL Gate and C _L = 100 pF
See Figures 12 and 13	

SST29LE010 OPERATING RANGE

Range	Ambient Temp	V _{CC}
Commercial	0°C to +70°C	3.0V to 3.6V
Industrial	-40°C to +85°C	3.0V to 3.6V

SST29VE010 OPERATING RANGE

Range	Ambient Temp	V _{CC}
Commercial	0°C to +70°C	2.7V to 3.6V
Industrial	-40°C to +85°C	2.7V to 3.6V



1 Megabit Page-Mode EEPROM SST29EE010/SST29LE010/SST29VE010

TABLE 5: SST29EE010 DC OPERATING CHARACTERISTICS $V_{CC} = 5V \pm 10\%$

Symbol	Parameter	Limits			Test Conditions
		Min	Max	Units	
I _{CC}	Power Supply Current Read		30	mA	CE#=OE#=V _{IL} , WE#=V _{IH} , all I/Os open, Address input = V _{IL} /V _{IH} , at f=1/T _{RC} Min., V _{CC} =V _{CC} Max
	Write		50	mA	
I _{SB1}	Standby V _{CC} Current (TTL input)		3	mA	CE#=OE#=WE#=V _{IH} , V _{CC} =V _{CC} Max.
I _{SB2}	Standby V _{CC} Current (CMOS input)		50	μA	CE#=OE#=WE#=V _{CC} -0.3V. V _{CC} = V _{CC} Max.
I _{LI}	Input Leakage Current		1	μA	V _{IN} =GND to V _{CC} , V _{CC} = V _{CC} Max.
I _{LO}	Output Leakage Current		10	μA	V _{OUT} =GND to V _{CC} , V _{CC} = V _{CC} Max.
V _{IL}	Input Low Voltage		0.8	V	V _{CC} = V _{CC} Min.
V _{IH}	Input High Voltage	2.0		V	V _{CC} = V _{CC} Max.
V _{OL}	Output Low Voltage		0.4	V	I _{OL} = 2.1 mA, V _{CC} = V _{CC} Min.
V _{OH}	Output High Voltage	2.4		V	I _{OH} = -400μA, V _{CC} = V _{CC} Min.
V _H	Supervoltage for A ₉	11.6	12.4	V	CE# = OE# = V _{IL} , WE# = V _{IH}
I _H	Supervoltage Current for A ₉		100	μA	CE# = OE# = V _{IL} , WE# = V _{IH} , A ₉ = V _H Max.

304 PGM T5.1

TABLE 6: SST29LE010/29VE010 DC OPERATING CHARACTERISTICS $V_{CC} = 3.0-3.6$ FOR SST29LE010, $V_{CC} = 2.7-3.6$ FOR SST29VE010

Symbol	Parameter	Limits			Test Conditions
		Min	Max	Units	
I _{CC}	Power Supply Current Read		12	mA	CE#=OE#=V _{IL} , WE#=V _{IH} , all I/Os open, Address input = V _{IL} /V _{IH} , at f=1/T _{RC} Min., V _{CC} =V _{CC} Max
	Write		15	mA	
I _{SB1}	Standby V _{CC} Current (TTL input)		1	mA	CE#=OE#=WE#=V _{IH} , V _{CC} =V _{CC} Max.
I _{SB2}	Standby V _{CC} Current (CMOS input)		15	μA	CE#=OE#=WE#=V _{CC} -0.3V. V _{CC} = V _{CC} Max.
I _{LI}	Input Leakage Current		1	μA	V _{IN} =GND to V _{CC} , V _{CC} = V _{CC} Max.
I _{LO}	Output Leakage Current		10	μA	V _{OUT} =GND to V _{CC} , V _{CC} = V _{CC} Max.
V _{IL}	Input Low Voltage		0.8	V	V _{CC} = V _{CC} Min.
V _{IH}	Input High Voltage	2.0		V	V _{CC} = V _{CC} Max.
V _{OL}	Output Low Voltage		0.4	V	I _{OL} = 100 μA, V _{CC} = V _{CC} Min.
V _{OH}	Output High Voltage	2.4		V	I _{OH} = -100 μA, V _{CC} = V _{CC} Min.
V _H	Supervoltage for A ₉	11.6	12.4	V	CE# = OE# = V _{IL} , WE# = V _{IH}
I _H	Supervoltage Current for A ₉		100	μA	CE# = OE# = V _{IL} , WE# = V _{IH} , A ₉ = V _H Max.

304 PGM T6.1



1 Megabit Page-Mode EEPROM

SST29EE010 / SST29LE010 / SST29VE010

TABLE 7: POWER-UP TIMINGS

Symbol	Parameter	Maximum	Units
$T_{PU-READ}^{(1)}$	Power-up to Read Operation	100	μs
$T_{PU-WRITE}^{(1)}$	Power-up to Write Operation	5	ms

304 PGM T7.0

TABLE 8: CAPACITANCE ($T_a = 25\text{ }^\circ\text{C}$, $f=1\text{ MHz}$, other pins open)

Parameter	Description	Test Condition	Maximum
$C_{I/O}^{(1)}$	I/O Pin Capacitance	$V_{I/O} = 0V$	12 pF
$C_{IN}^{(1)}$	Input Capacitance	$V_{IN} = 0V$	6 pF

304 PGM T8.0

Note: ⁽¹⁾This parameter is measured only for initial qualification and after a design or process change that could affect this parameter.

TABLE 9: RELIABILITY CHARACTERISTICS

Symbol	Parameter	Minimum Specification	Units	Test Method
N_{END}	Endurance	10,000	Cycles	JEDEC Standard A117
$T_{DR}^{(1)}$	Data Retention	100	Years	JEDEC Standard A103
$V_{ZAP_HBM}^{(1)}$	ESD Susceptibility Human Body Model	2000	Volts	JEDEC Standard A114
$V_{ZAP_MM}^{(1)}$	ESD Susceptibility Machine Model	200	Volts	JEDEC Standard A115
$I_{LTH}^{(1)}$	Latch Up	100	mA	JEDEC Standard 78

304 PGM T9.3

Note: ⁽¹⁾This parameter is measured only for initial qualification and after a design or process change that could affect this parameter.



1 Megabit Page-Mode EEPROM SST29EE010/SST29LE010/SST29VE010

AC CHARACTERISTICS

TABLE 10: SST29EE010 READ CYCLE TIMING PARAMETERS

Symbol	Parameter	SST29EE010-90		SST29EE010-120		Units
		Min	Max	Min	Max	
T _{RC}	Read Cycle Time	90		120		ns
T _{CE}	Chip Enable Access Time		90		120	ns
T _{AA}	Address Access Time		90		120	ns
T _{OE}	Output Enable Access Time		40		50	ns
T _{CLZ} ⁽¹⁾	CE# Low to Active Output	0		0		ns
T _{OLZ} ⁽¹⁾	OE# Low to Active Output	0		0		ns
T _{CHZ} ⁽¹⁾	CE# High to High-Z Output		30		30	ns
T _{OHZ} ⁽¹⁾	OE# High to High-Z Output		30		30	ns
T _{OH} ⁽¹⁾	Output Hold from Address Change	0		0		ns

304 PGM T10.1

TABLE 11: SST29LE010 READ CYCLE TIMING PARAMETERS

Symbol	Parameter	SST29LE010-150		SST29LE010-200		Units
		Min	Max	Min	Max	
T _{RC}	Read Cycle Time	150		200		ns
T _{CE}	Chip Enable Access Time		150		200	ns
T _{AA}	Address Access Time		150		200	ns
T _{OE}	Output Enable Access Time		60		100	ns
T _{CLZ} ⁽¹⁾	CE# Low to Active Output	0		0		ns
T _{OLZ} ⁽¹⁾	OE# Low to Active Output	0		0		ns
T _{CHZ} ⁽¹⁾	CE# High to High-Z Output		30		50	ns
T _{OHZ} ⁽¹⁾	OE# High to High-Z Output		30		50	ns
T _{OH} ⁽¹⁾	Output Hold from Address Change	0		0		ns

304 PGM T11.0

TABLE 12: SST29VE010 READ CYCLE TIMING PARAMETERS

Symbol	Parameter	SST29VE010-200		SST29VE010-250		Units
		Min	Max	Min	Max	
T _{RC}	Read Cycle Time	200		250		ns
T _{CE}	Chip Enable Access Time		200		250	ns
T _{AA}	Address Access Time		200		250	ns
T _{OE}	Output Enable Access Time		100		120	ns
T _{CLZ} ⁽¹⁾	CE# Low to Active Output	0		0		ns
T _{OLZ} ⁽¹⁾	OE# Low to Active Output	0		0		ns
T _{CHZ} ⁽¹⁾	CE# High to High-Z Output		50		50	ns
T _{OHZ} ⁽¹⁾	OE# High to High-Z Output		50		50	ns
T _{OH} ⁽¹⁾	Output Hold from Address Change	0		0		ns

304 PGM T12.0



1 Megabit Page-Mode EEPROM

SST29EE010 / SST29LE010 / SST29VE010

TABLE 13: PAGE-WRITE CYCLE TIMING PARAMETERS

Symbol	Parameter	SST29EE010		SST29LE/VE010		Units
		Min	Max	Min	Max	
T _{WC}	Write Cycle (Erase and Program)		10		10	ms
T _{AS}	Address Setup Time	0		0		ns
T _{AH}	Address Hold Time	50		70		ns
T _{CS}	WE# and CE# Setup Time	0		0		ns
T _{CH}	WE# and CE# Hold Time	0		0		ns
T _{OES}	OE# High Setup Time	0		0		ns
T _{OEH}	OE# High Hold Time	0		0		ns
T _{CP}	CE# Pulse Width	70		120		ns
T _{WP}	WE# Pulse Width	70		120		ns
T _{DS}	Data Setup Time	35		50		ns
T _{DH}	Data Hold Time	0		0		ns
T _{BLC} ⁽¹⁾	Byte Load Cycle Time	0.05	100	0.05	100	μs
T _{BLCO} ⁽¹⁾	Byte Load Cycle Time	200		200		μs
T _{IDA}	Software ID Access and Exit Time		10		10	μs
T _{SCE}	Software Chip-Erase		20		20	ms

304 PGM T13.3

Note: ⁽¹⁾This parameter is measured only for initial qualification and after the design or process change that could affect this parameter.



1 Megabit Page-Mode EEPROM SST29EE010/SST29LE010/SST29VE010

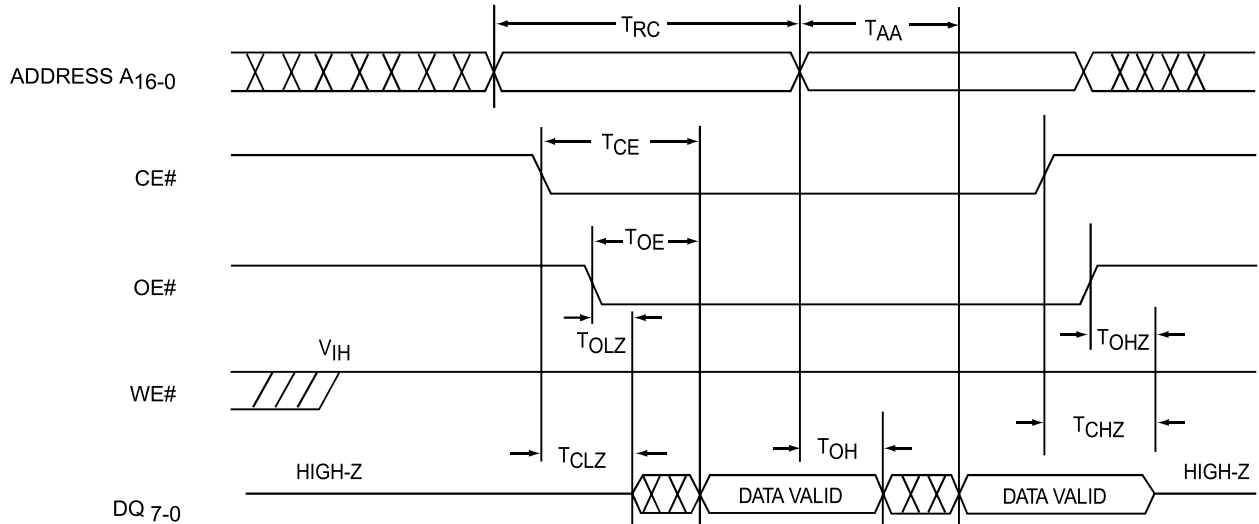

304 ILL F03.0

FIGURE 3: READ CYCLE TIMING DIAGRAM

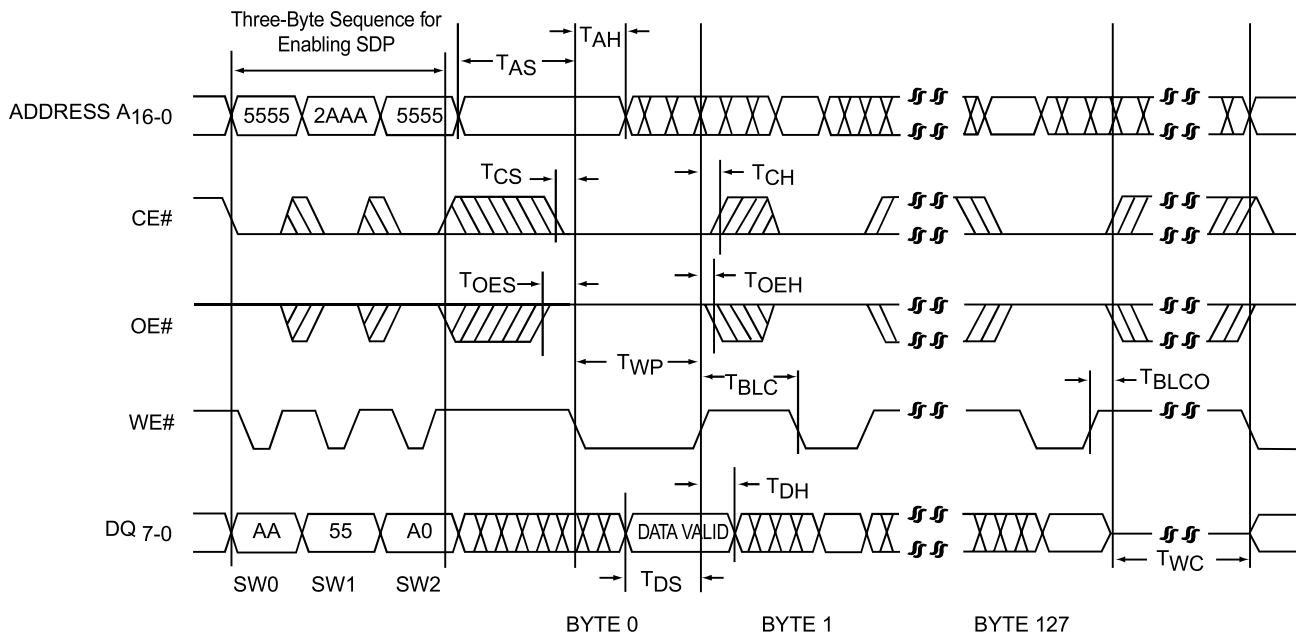

304 ILL F04.1

FIGURE 4: WE# CONTROLLED PAGE-WRITE CYCLE TIMING DIAGRAM



1 Megabit Page-Mode EEPROM SST29EE010 / SST29LE010 / SST29VE010

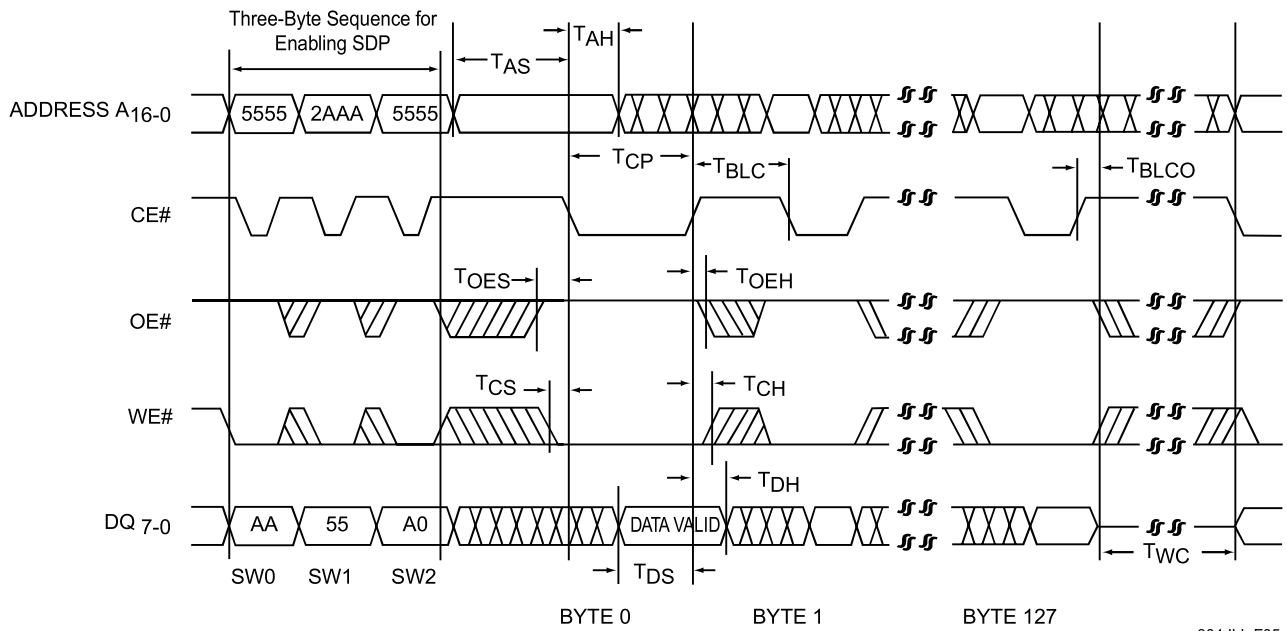

FIGURE 5: CE# CONTROLLED PAGE-WRITE CYCLE TIMING DIAGRAM

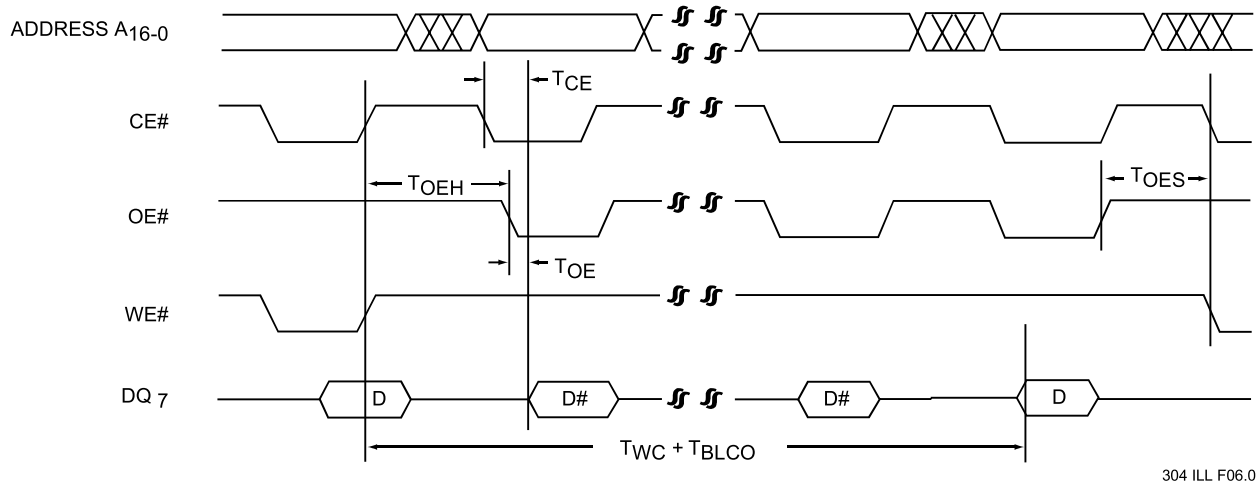

FIGURE 6: DATA# POLLING TIMING DIAGRAM



1 Megabit Page-Mode EEPROM SST29EE010/SST29LE010/SST29VE010

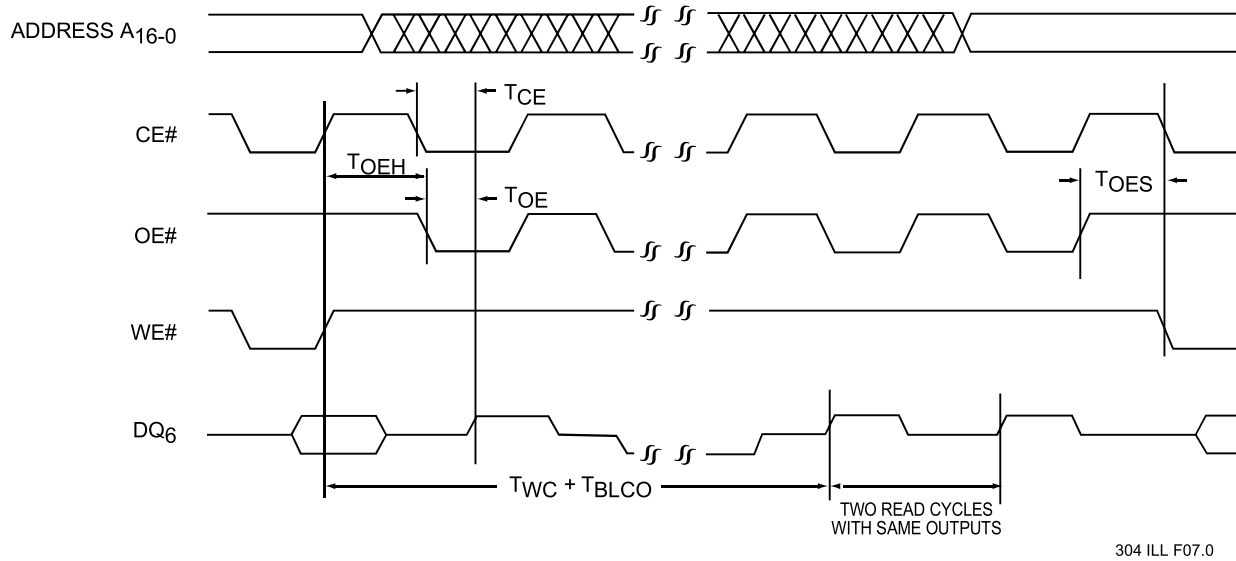

FIGURE 7: TOGGLE BIT TIMING DIAGRAM

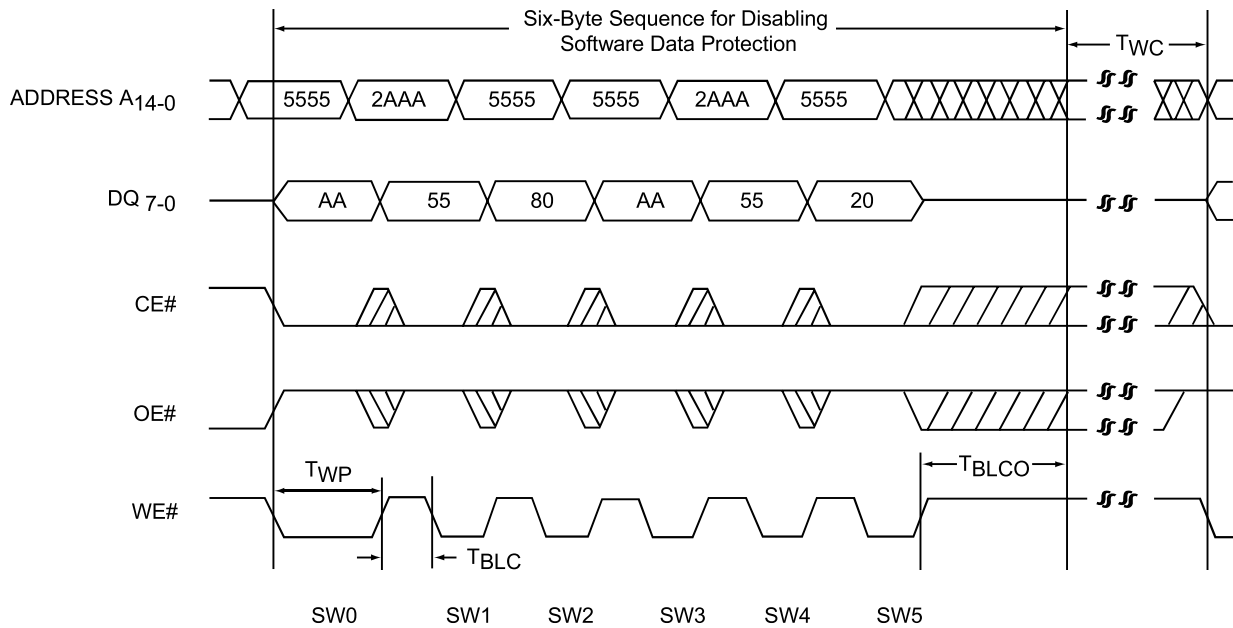
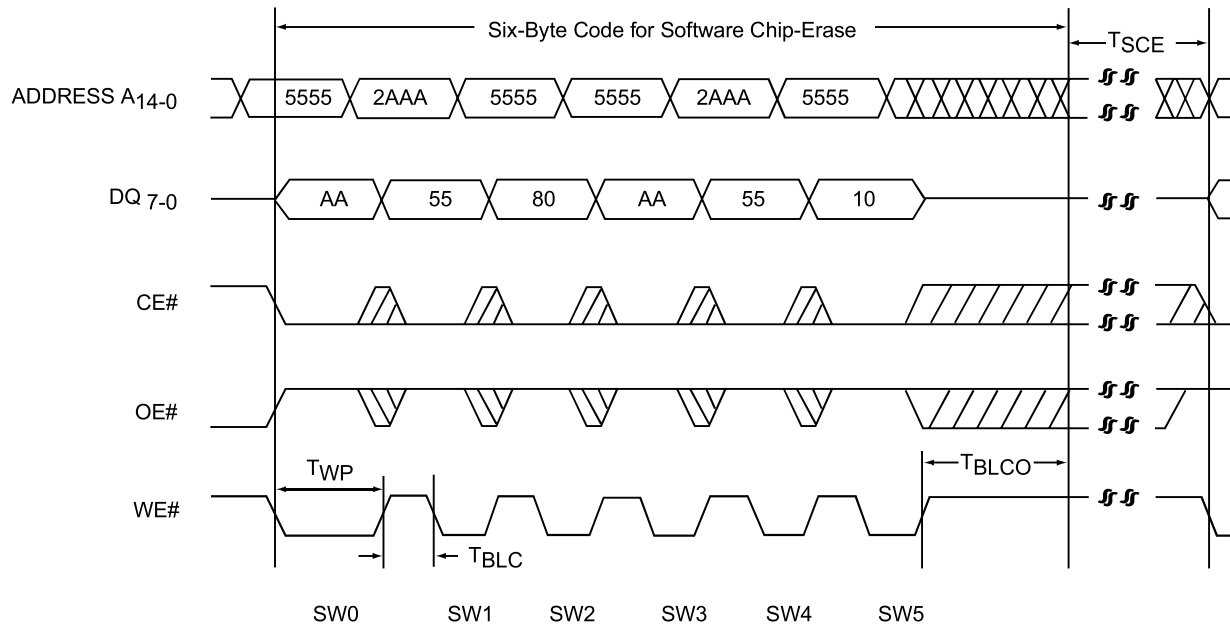

FIGURE 8: SOFTWARE DATA PROTECT DISABLE TIMING DIAGRAM



1 Megabit Page-Mode EEPROM SST29EE010 / SST29LE010 / SST29VE010



304 ILL F09.1

FIGURE 9: SOFTWARE CHIP-ERASE TIMING DIAGRAM

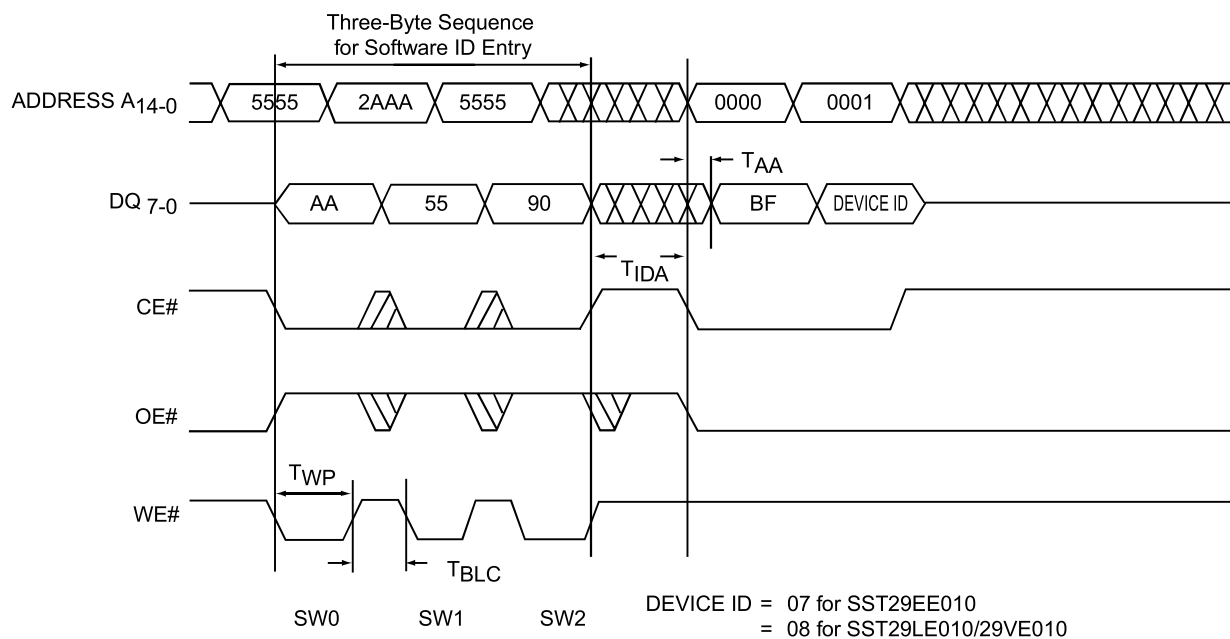

304 ILL F10.1

FIGURE 10: SOFTWARE ID ENTRY AND READ

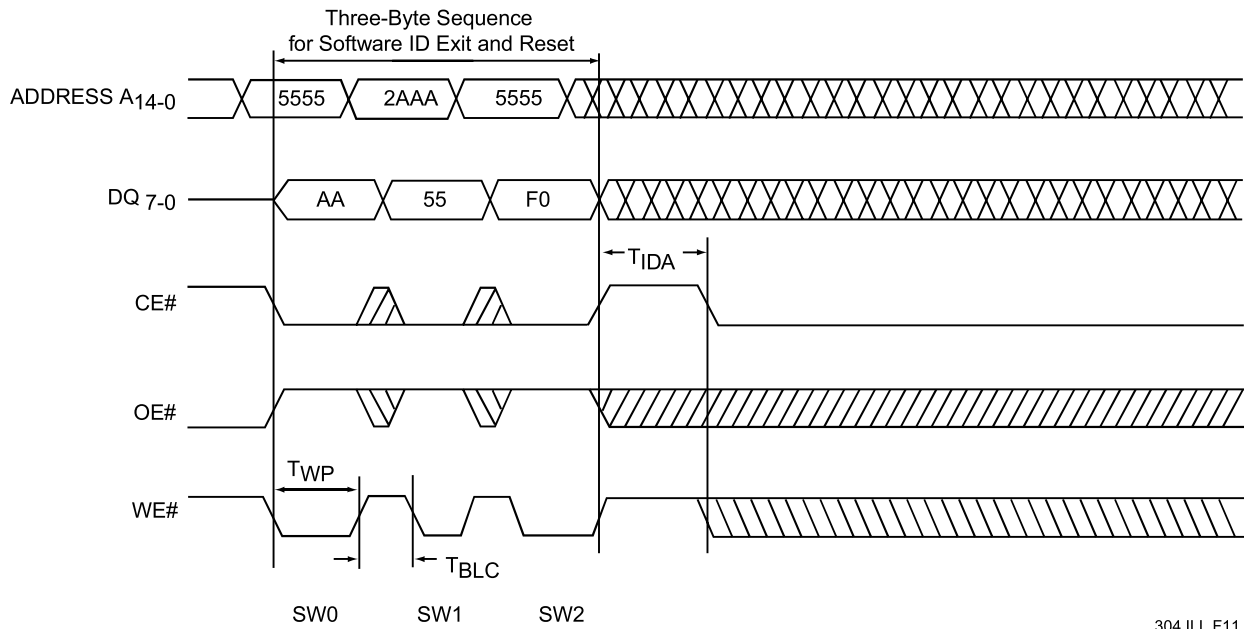

304 ILL F11.0

FIGURE 11: SOFTWARE ID EXIT AND RESET



1 Megabit Page-Mode EEPROM SST29EE010 / SST29LE010 / SST29VE010

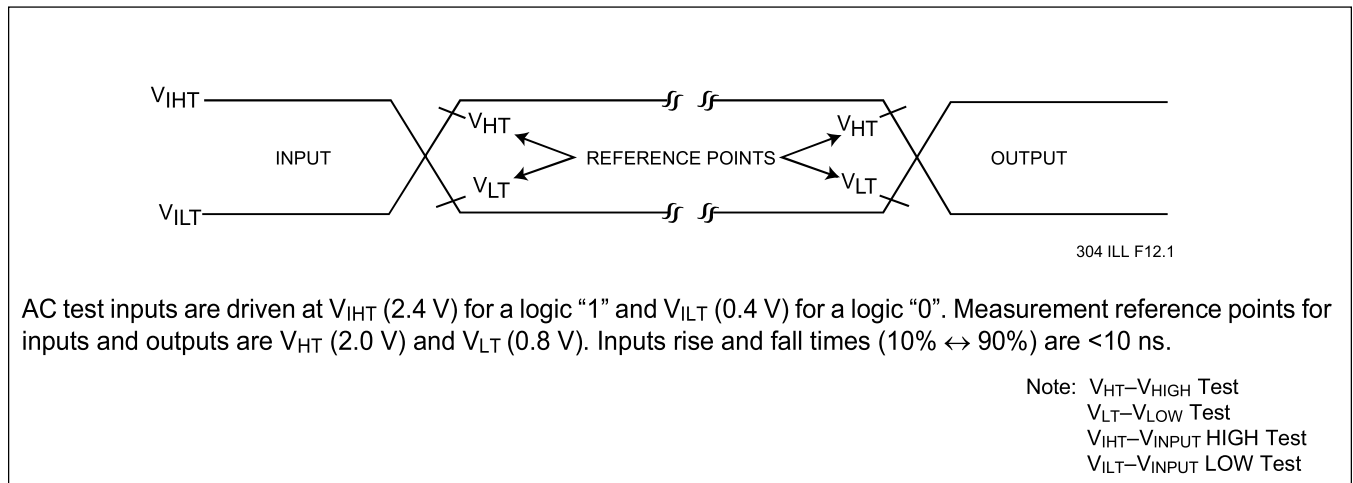

FIGURE 12: AC INPUT/OUTPUT REFERENCE WAVEFORMS

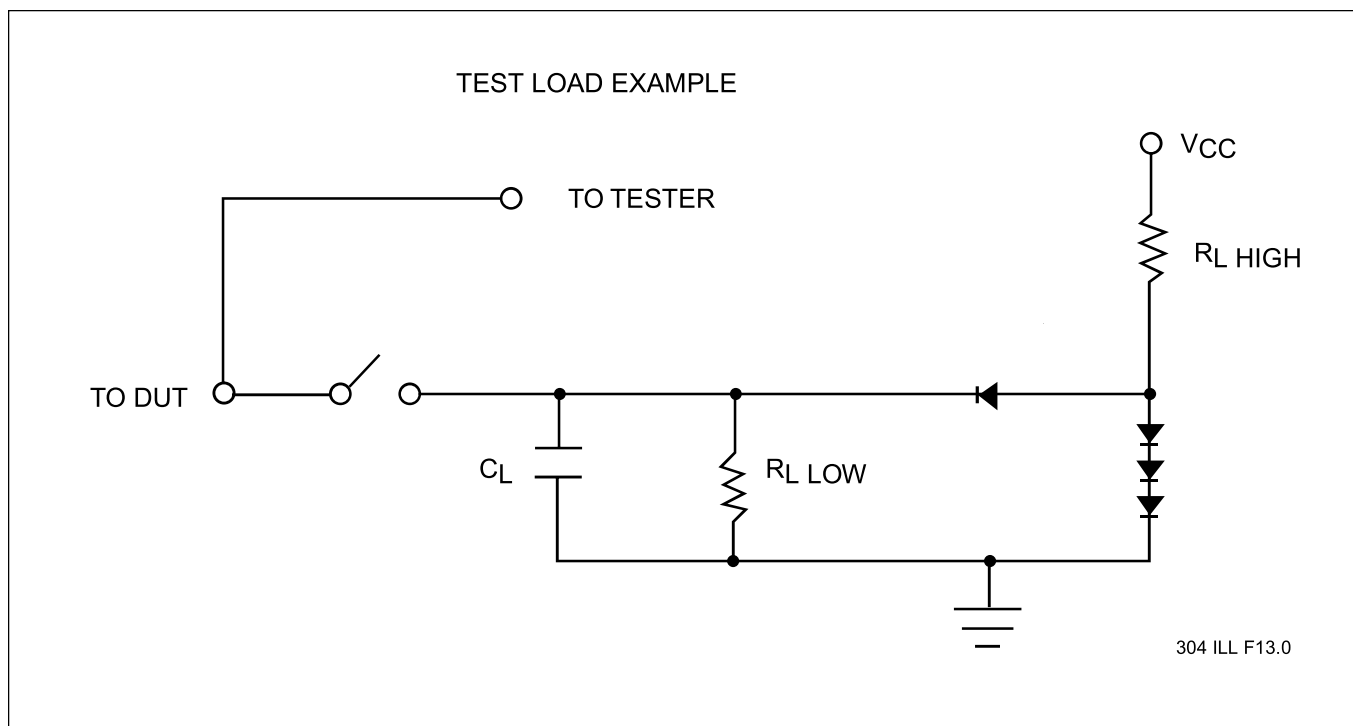

FIGURE 13: A TEST LOAD EXAMPLE

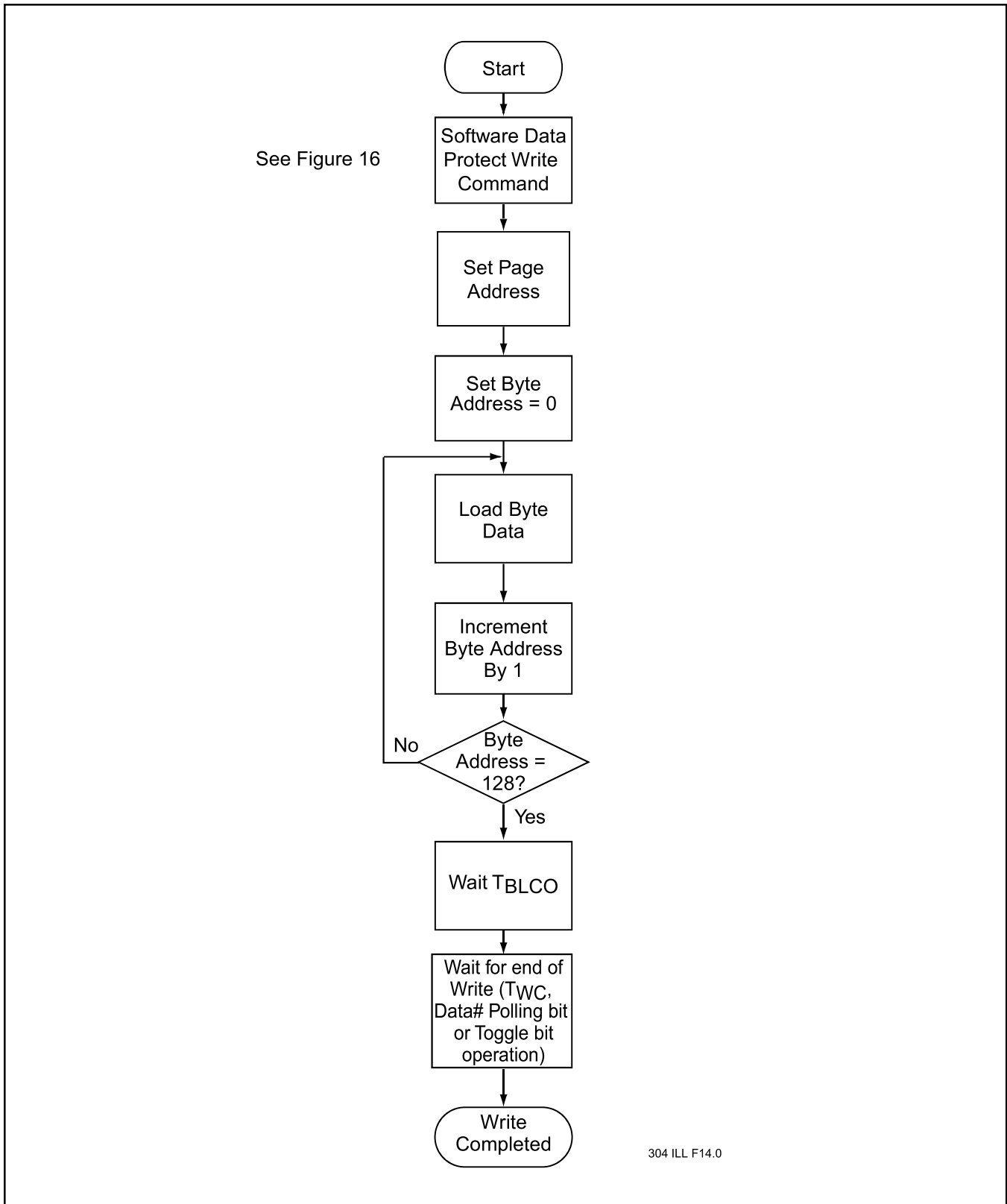

FIGURE 14: WRITE ALGORITHM



1 Megabit Page-Mode EEPROM SST29EE010 / SST29LE010 / SST29VE010

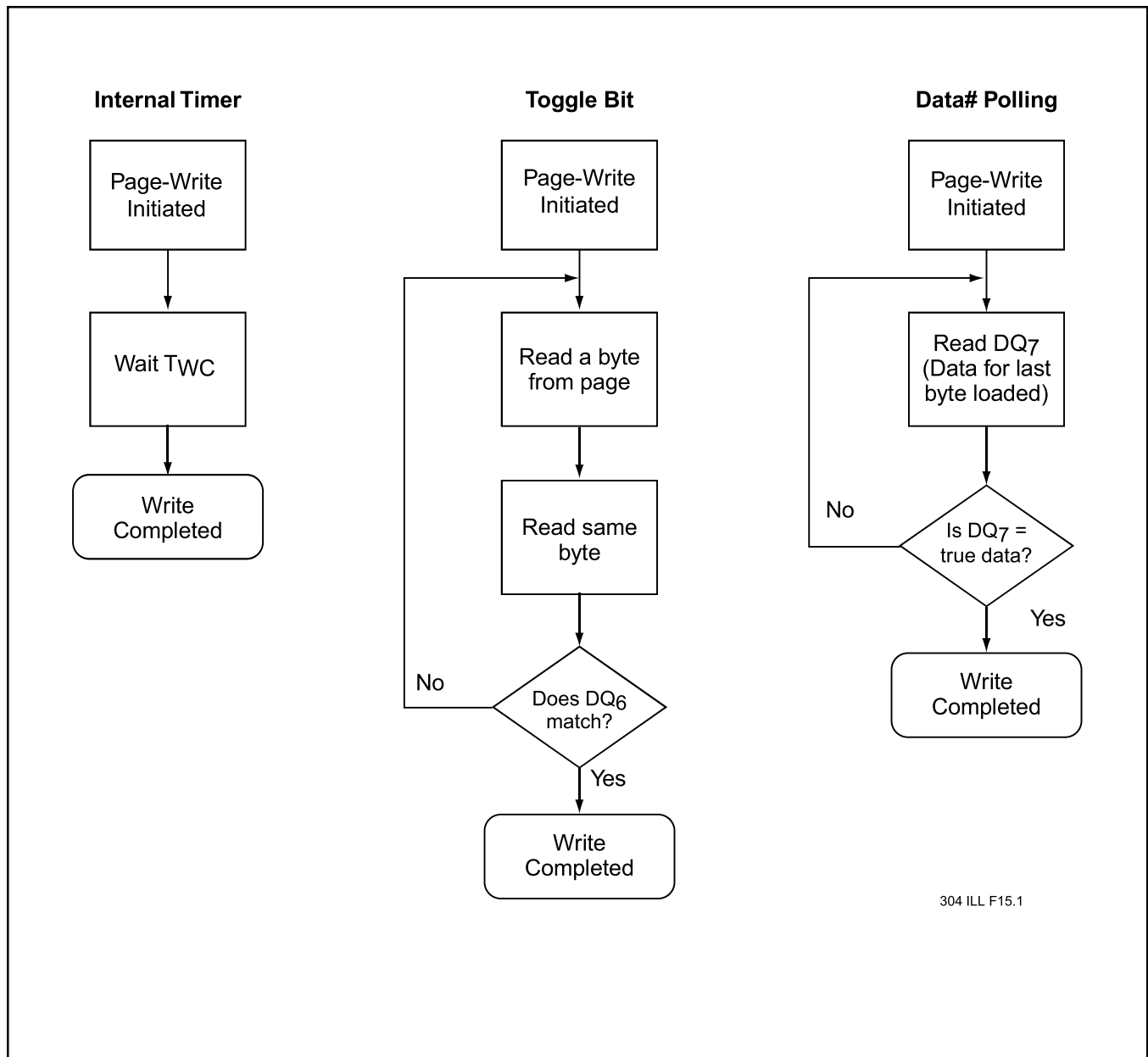

FIGURE 15: WAIT OPTIONS

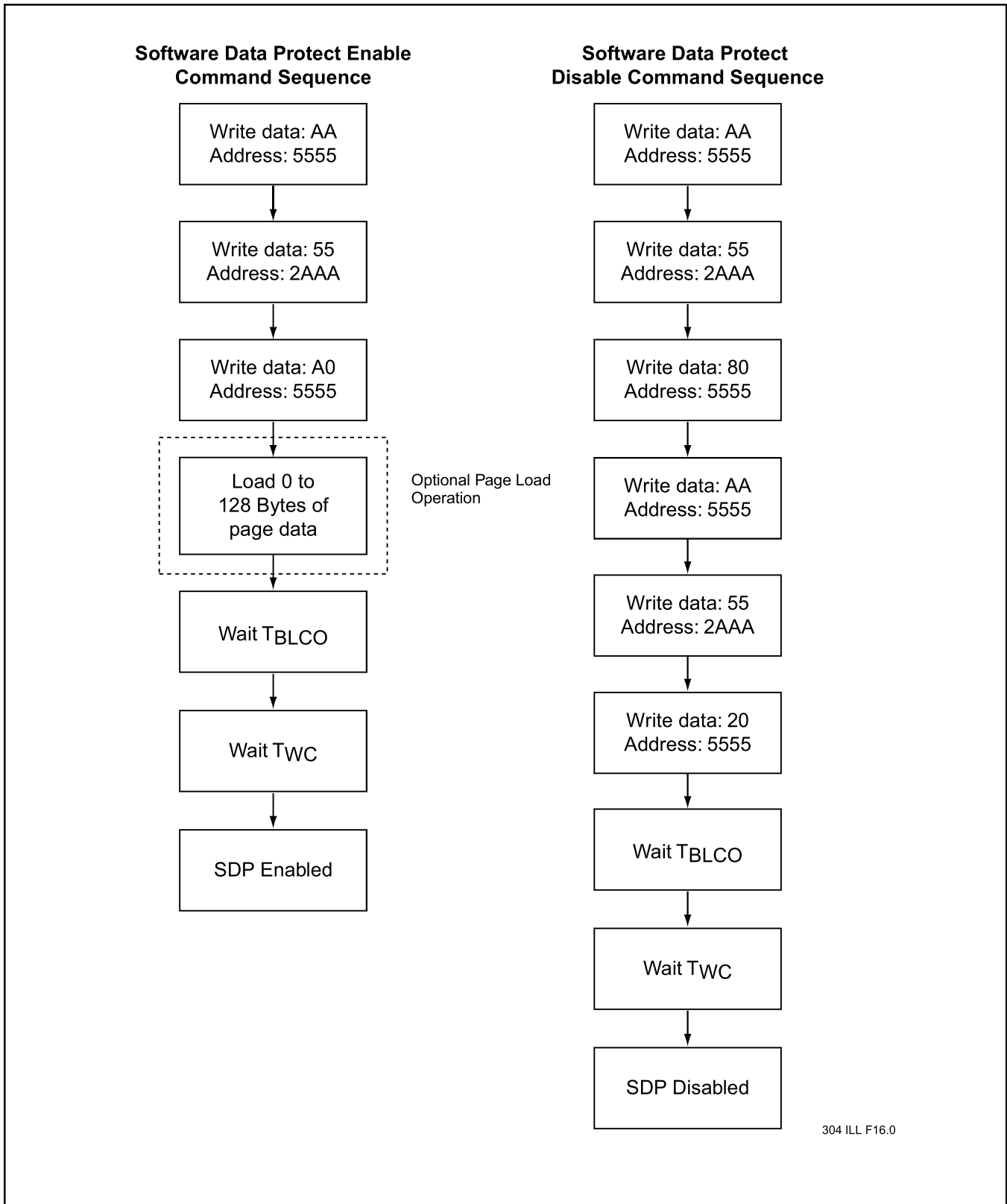

FIGURE 16: SOFTWARE DATA PROTECTION FLOWCHARTS

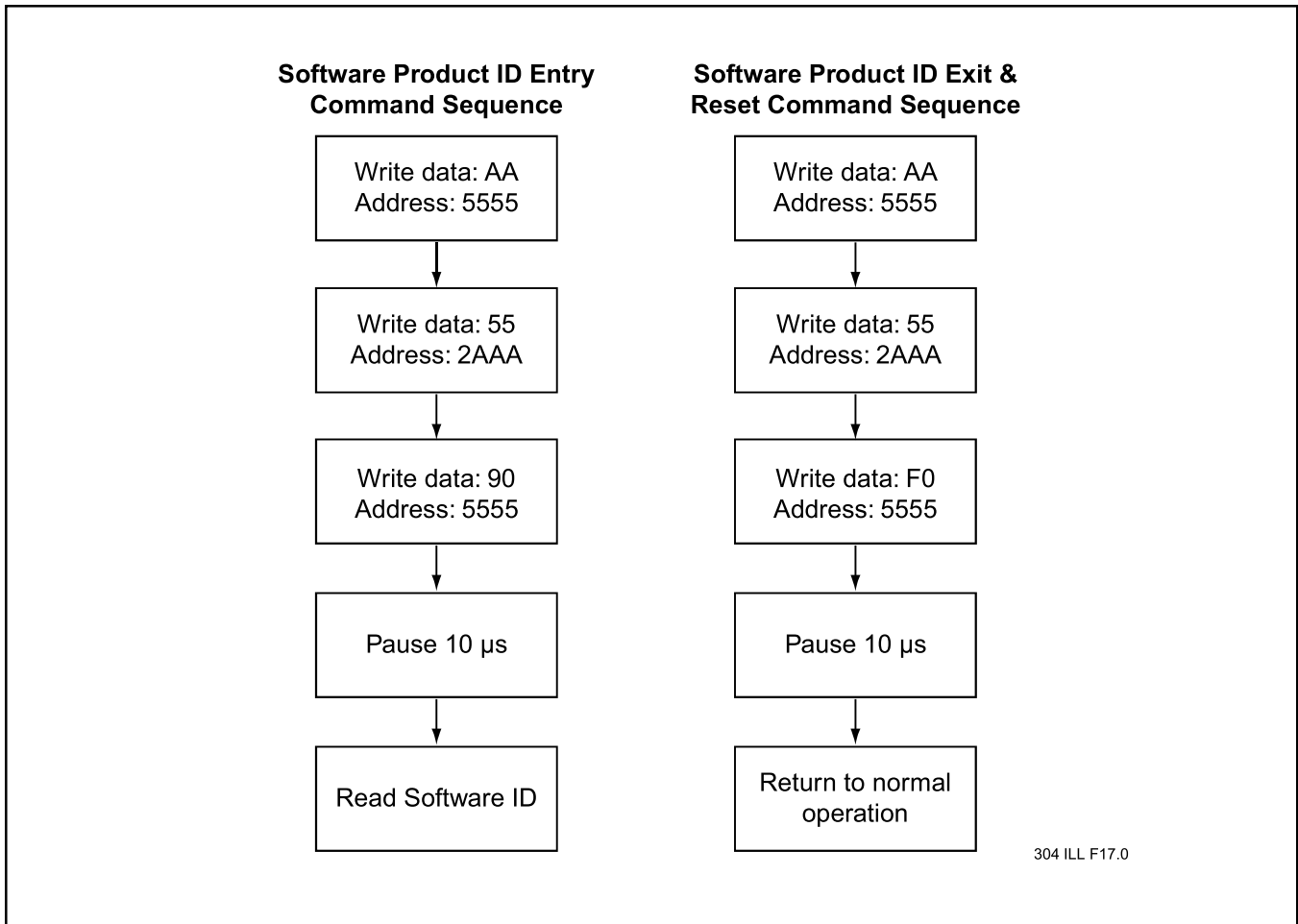

FIGURE 17: SOFTWARE PRODUCT COMMAND FLOWCHARTS

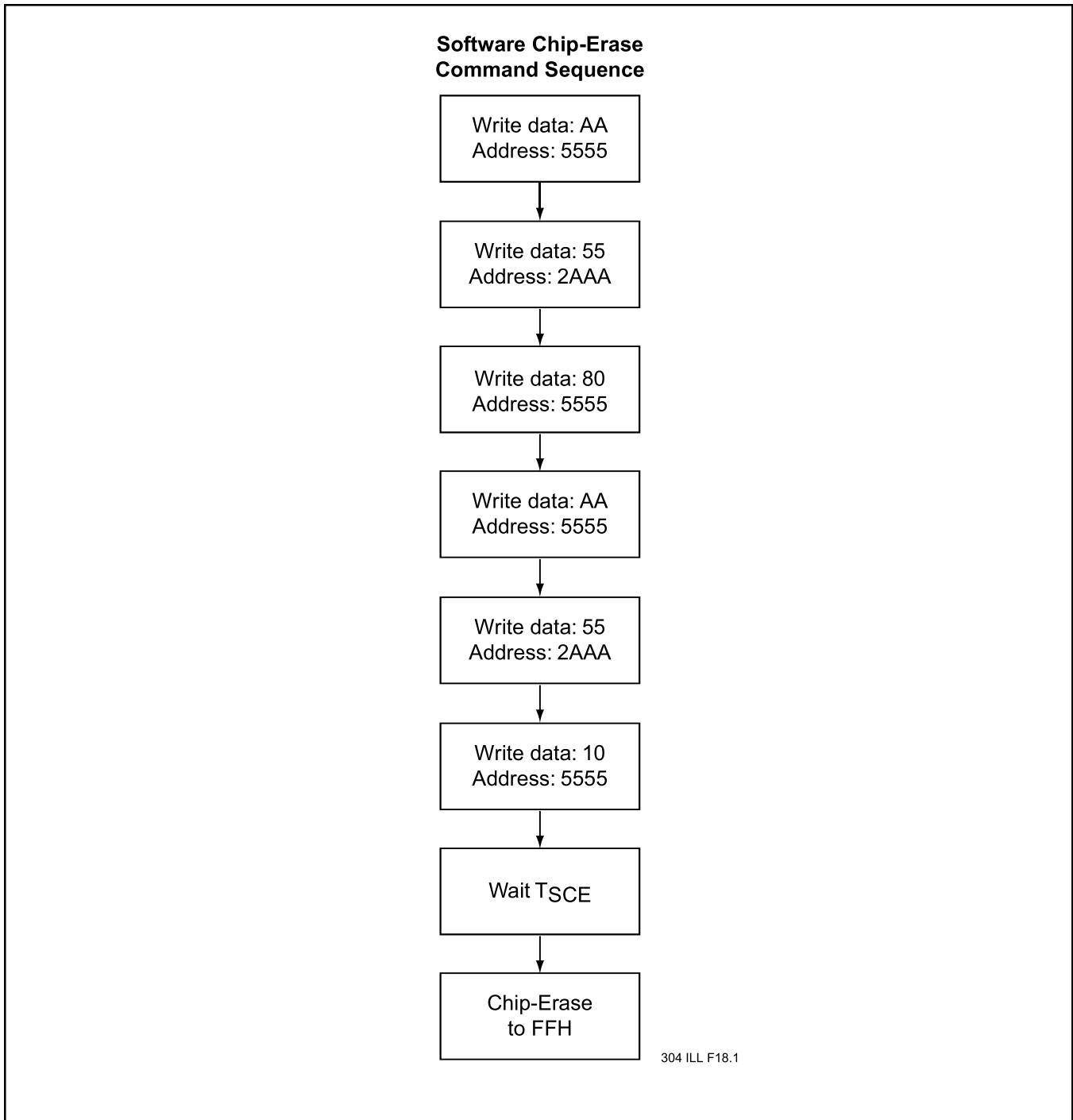

FIGURE 18: SOFTWARE CHIP-ERASE COMMAND CODES



1 Megabit Page-Mode EEPROM SST29EE010 / SST29LE010 / SST29VE010

PRODUCT ORDERING INFORMATION

Device Speed Suffix1 Suffix2

SST29xE010 - XXX - XX - XX

Package Modifier

H = 32 leads
Numeric = Die modifier

Package Type

P = PDIP
N = PLCC
E = TSOP (die up) 8mm x 20mm
W = TSOP (die up) 8mm x 14mm
U = Unencapsulated die

Operating Temperature

C = Commercial = 0° to 70°C
I = Industrial = -40° to 85°C

Minimum Endurance

4 = 10,000 cycles

Read Access Speed

250 = 250 ns
200 = 200 ns
150 = 150 ns
120 = 120 ns
90 = 90 ns

Voltage

E = 5.0V-only
L = 3.0-3.6V
V = 2.7-3.6V



1 Megabit Page-Mode EEPROM SST29EE010/SST29LE010/SST29VE010

SST29EE010 Valid combinations

SST29EE010-90-4C-EH	SST29EE010-90-4C-NH	SST29EE010-90-4C-PH
SST29EE010-120-4C-EH	SST29EE010-120-4C-NH	SST29EE010-120-4C-PH

SST29EE010-90-4C-WH
SST29EE010-120-4C-WH

SST29EE010-90-4I-EH	SST29EE010-90-4I-NH	SST29EE010-90-4I-WH
---------------------	---------------------	---------------------

SST29EE010-120-4C-U2

SST29LE010 Valid combinations

SST29LE010-150-4C-EH	SST29LE010-150-4C-NH	SST29LE010-150-4C-WH
SST29LE010-150-4I-EH	SST29LE010-150-4I-NH	SST29LE010-150-4I-WH

SST29LE010-200-4C-U2

SST29VE010 Valid combinations

SST29VE010-200-4C-EH	SST29VE010-200-4C-NH	SST29VE010-200-4C-WH
SST29VE010-200-4I-EH	SST29VE010-200-4I-NH	SST29VE010-200-4I-WH

SST29VE010-250-4C-U2

Example: Valid combinations are those products in mass production or will be in mass production. Consult your SST sales representative to confirm availability of valid combinations and to determine availability of new combinations.

Note: The software Chip-Erase function is not supported by the industrial temperature part. Please contact SST, if you require this function for an industrial temperature part.



1 Megabit Page-Mode EEPROM

SST29EE010 / SST29LE010 / SST29VE010

PACKAGING DIAGRAMS

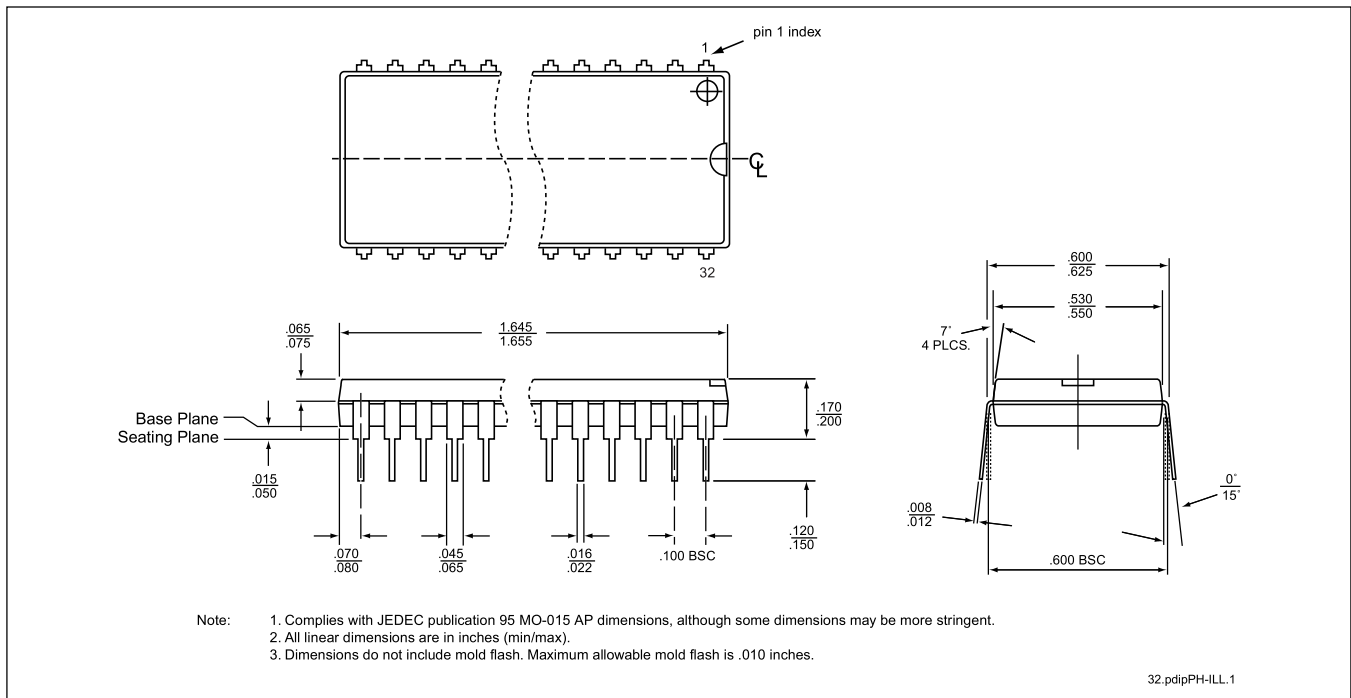

32-LEAD PLASTIC DUAL-IN-LINE PACKAGE (PDIP)

SST PACKAGE CODE: PH

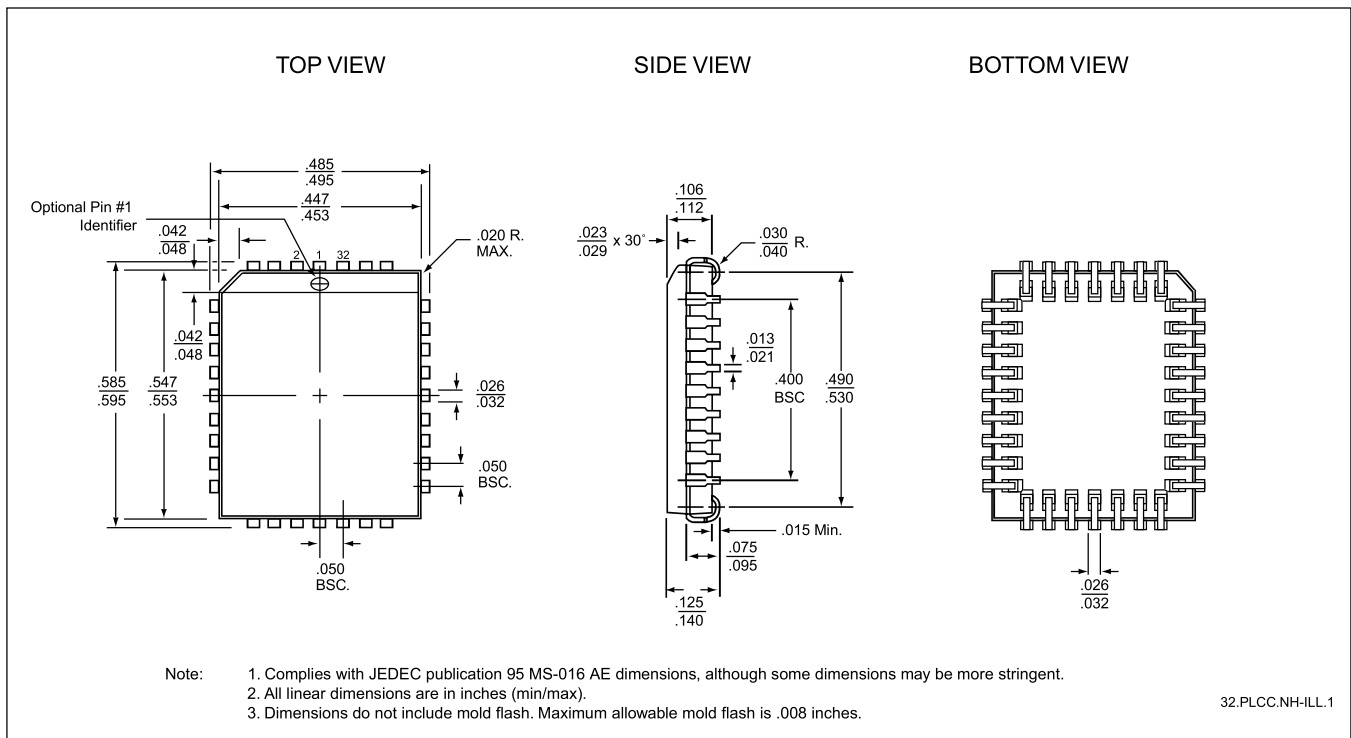

32-LEAD PLASTIC LEAD CHIP CARRIER (PLCC)

SST PACKAGE CODE: NH



1 Megabit Page-Mode EEPROM SST29EE010/SST29LE010/SST29VE010

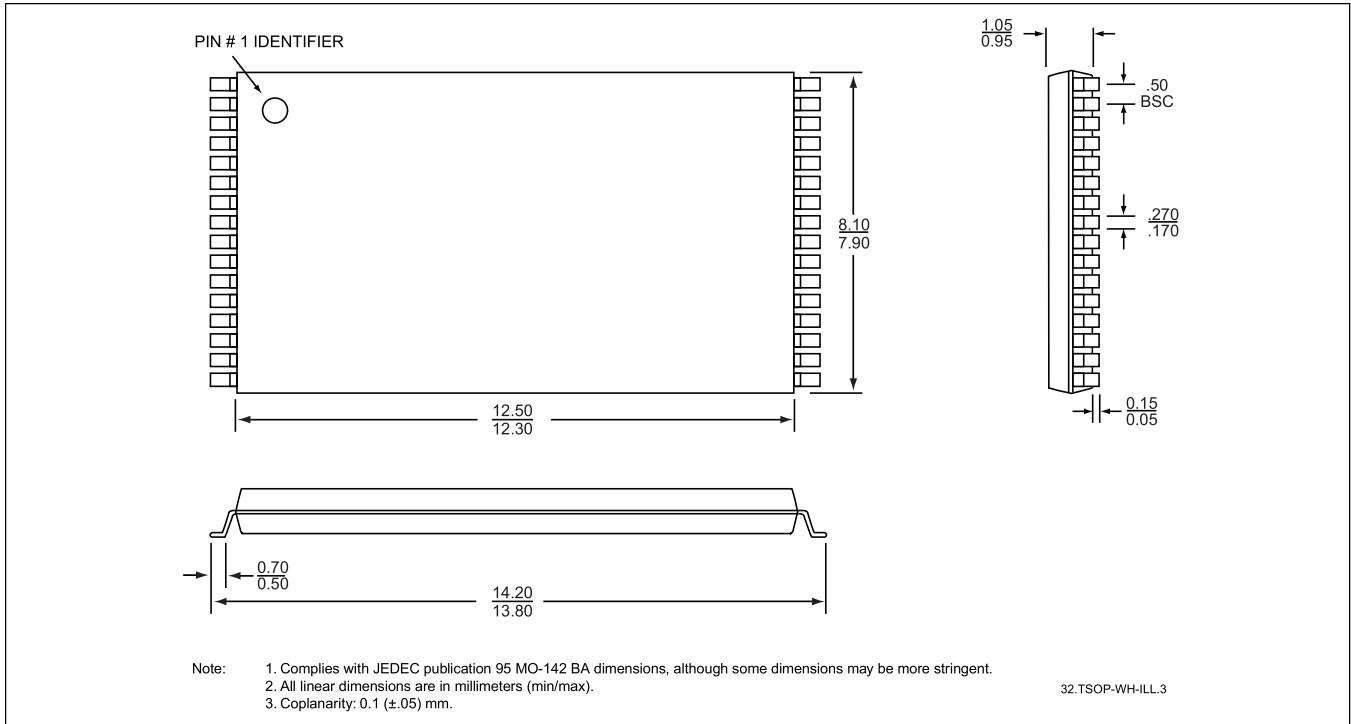

32-LEAD THIN SMALL OUTLINE PACKAGE (TSOP) 8MM X 14MM

SST PACKAGE CODE: WH

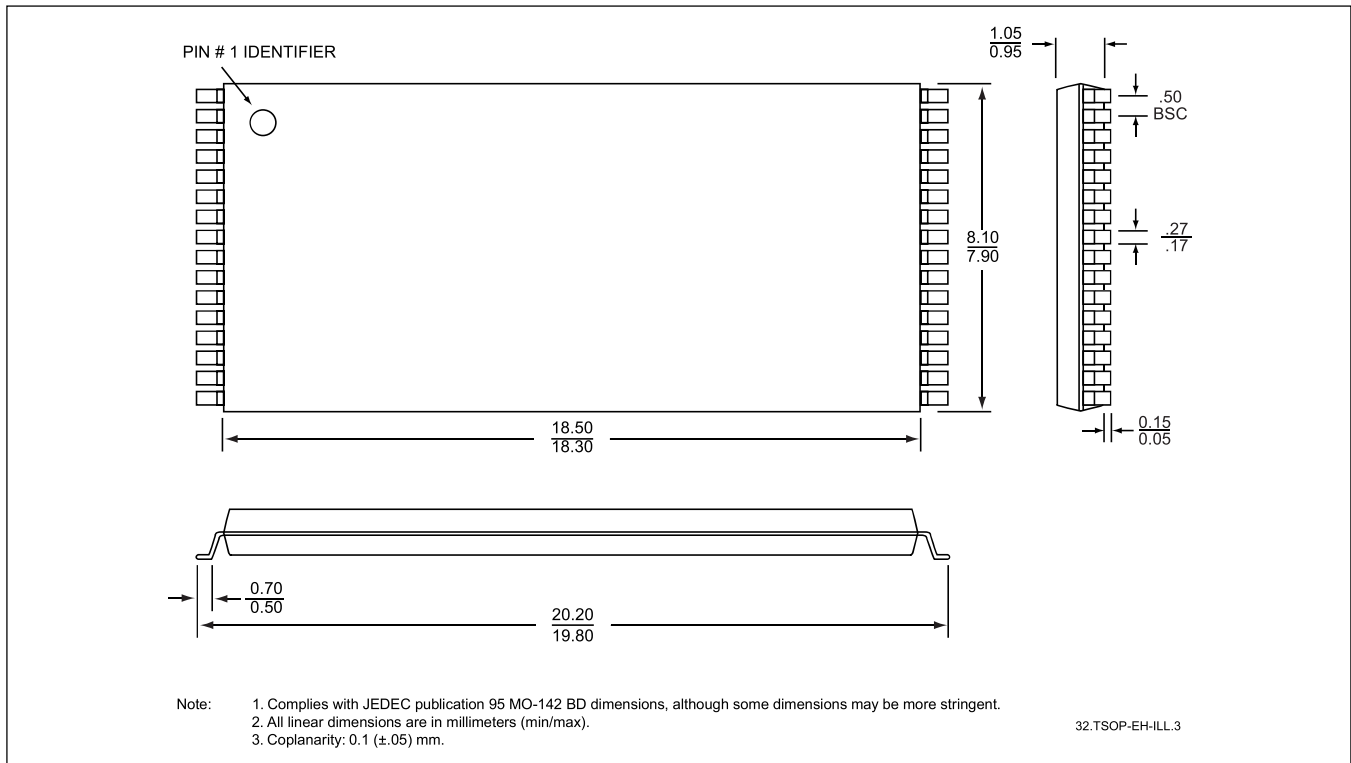

32-LEAD THIN SMALL OUTLINE PACKAGE (TSOP) 8MM X 20MM

SST PACKAGE CODE: EH