

# HCNR200 and HCNR201

## High-Linearity Analog Optocouplers

### Description

The Broadcom<sup>®</sup> HCNR200/201 high-linearity analog optocoupler consists of a high-performance AlGaAs LED that illuminates two closely matched photodiodes. The input photodiode monitors, and therefore stabilizes, the light output of the LED. As a result, the nonlinearity and drift characteristics of the LED can be virtually eliminated. The output photodiode produces a photocurrent that is linearly related to the light output of the LED. The close matching of the photodiodes and advanced design of the package ensure the high linearity and stable gain characteristics of the optocoupler.

The HCNR200/201 isolates analog signals in a wide variety of applications that require good stability, linearity, bandwidth, and low cost. The HCNR200/201 is flexible and, by appropriate design of the application circuit, is capable of operating in many different modes, including unipolar/bipolar, AC/DC and inverting/noninverting. The HCNR200/201 is an excellent solution for many analog isolation problems.

### Features

- Low nonlinearity: 0.01%
- K3 (IPD2/IPD1) transfer gain
  - HCNR200: ±15%
  - HCNR201: ±5%
- Low gain temperature coefficient: 65 ppm/°C
- Wide bandwidth – DC to >1 MHz
- Worldwide safety approval
  - UL 1577 recognized (5 kV rms/1 min. rating)
  - CSA approved
  - IEC/EN/DIN EN 60747-5-5 approved
  - $V_{IORM} = 1414 V_{peak}$  (option -050E/-350E/-550E)
- Surface mount option available (Option #300)
- 8-pin DIP package – 0.400-in. spacing
- Allows flexible circuit design

### Applications

- Low cost analog isolation
- Telecom: Modem, PBX
- Industrial process control:
  - Transducer isolator
  - Isolator for thermocouples 4 mA to 20 mA loop isolation
- SMPS feedback loop, SMPS feedforward
- Monitor motor supply voltage
- Medical

**CAUTION!** Take normal static precautions in handling and assembly of this component to prevent damage and/or degradation which may be induced by ESD. The components featured in this data sheet are not to be used in military or aerospace applications or environments. The components are not AEC-Q100 qualified and not recommended for automotive applications.

# Schematic

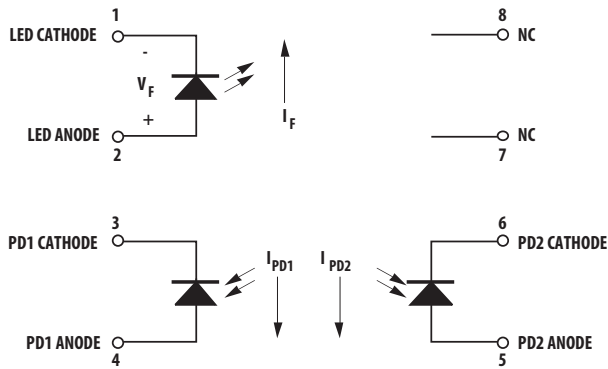

# Ordering Information

HCNR200/HCNR201 is UL Recognized with 5000 Vrms for 1 minute per UL1577.

Part Number	Option		Package	Surface Mount	Gull Wing	Tape and Reel	UL 5000 Vrms/ 1 Minute rating	IEC/EN/DIN EN 60747-5-5 V <sub>IORM</sub> = 1414 V <sub>peak</sub>	Quantity
	RoHS Compliant	Non-RoHS Compliant							
HCNR200	-000E	no option	400-mil				X		42 per tube
HCNR201	-300E	#300	Widebody DIP-8	X	X		X		42 per tube
	-500E	#500		X	X	X	X		750 per reel
	-050E	#050					X	X	42 per tube
	-350E	#350		X	X		X	X	42 per tube
	-550E	#550		X	X	X	X	X	750 per reel

To order, choose a part number from the part number column and combine with the desired option from the option column to form an order entry.

### Example 1:

HCNR200-550E to order product of Gull Wing Surface Mount package in Tape and Reel packaging with IEC/EN/ DIN EN 60747-5-5 V<sub>IORM</sub> = 1414 V<sub>peak</sub> Safety Approval and UL 5000 Vrms for 1 minute rating and RoHS compliant.

### Example 2:

HCNR201 to order product of 8-Pin Widebody DIP package in Tube packaging with UL 5000 Vrms for 1 minute rating and non RoHS compliant.

Option data sheets are available. Contact your Broadcom sales representative or authorized distributor for information.

**NOTE:** The notation '#XXX' is used for existing products, while (new) products launched since July 15, 2001 and RoHS compliant will use '-XXXE'.

# Package Outline Drawings

Figure 1: 8-Pin DIP

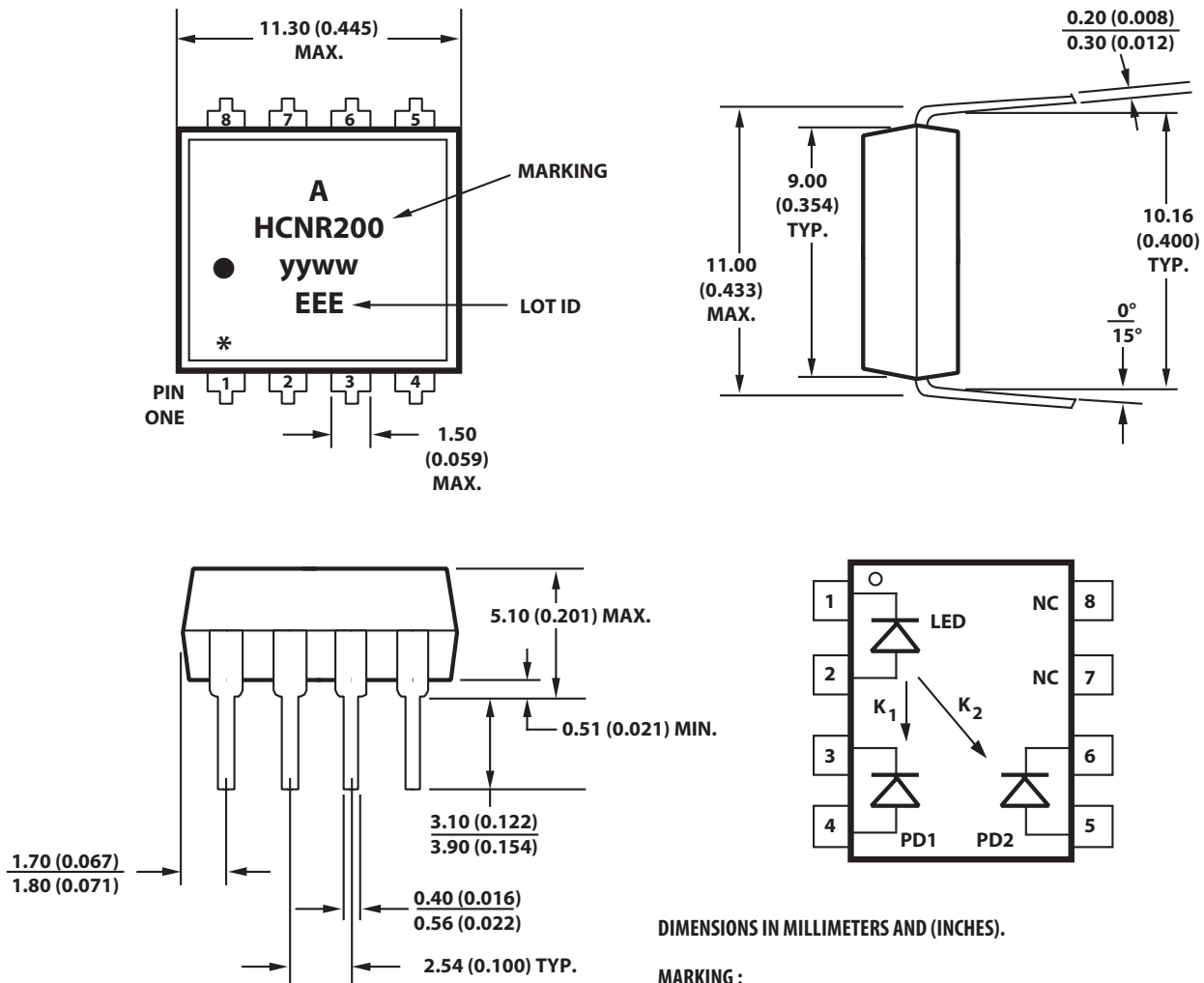

DIMENSIONS IN MILLIMETERS AND (INCHES).

**MARKING :**

- yy - Year
- ww - Work Week
- Marked with black dot - Designates Lead Free option E
- XXX = 050 ONLY if option #050, #350, #550 (or -050, -350, -550) ordered (otherwise blank)
- \* - Designates pin 1

**NOTE: FLOATING LEAD PROTRUSION IS 0.25 mm (10 mils) MAX.**

# Gull Wing Surface Mount Option #300

Figure 2: 8-Pin Gull Wing Surface Mount Option #300

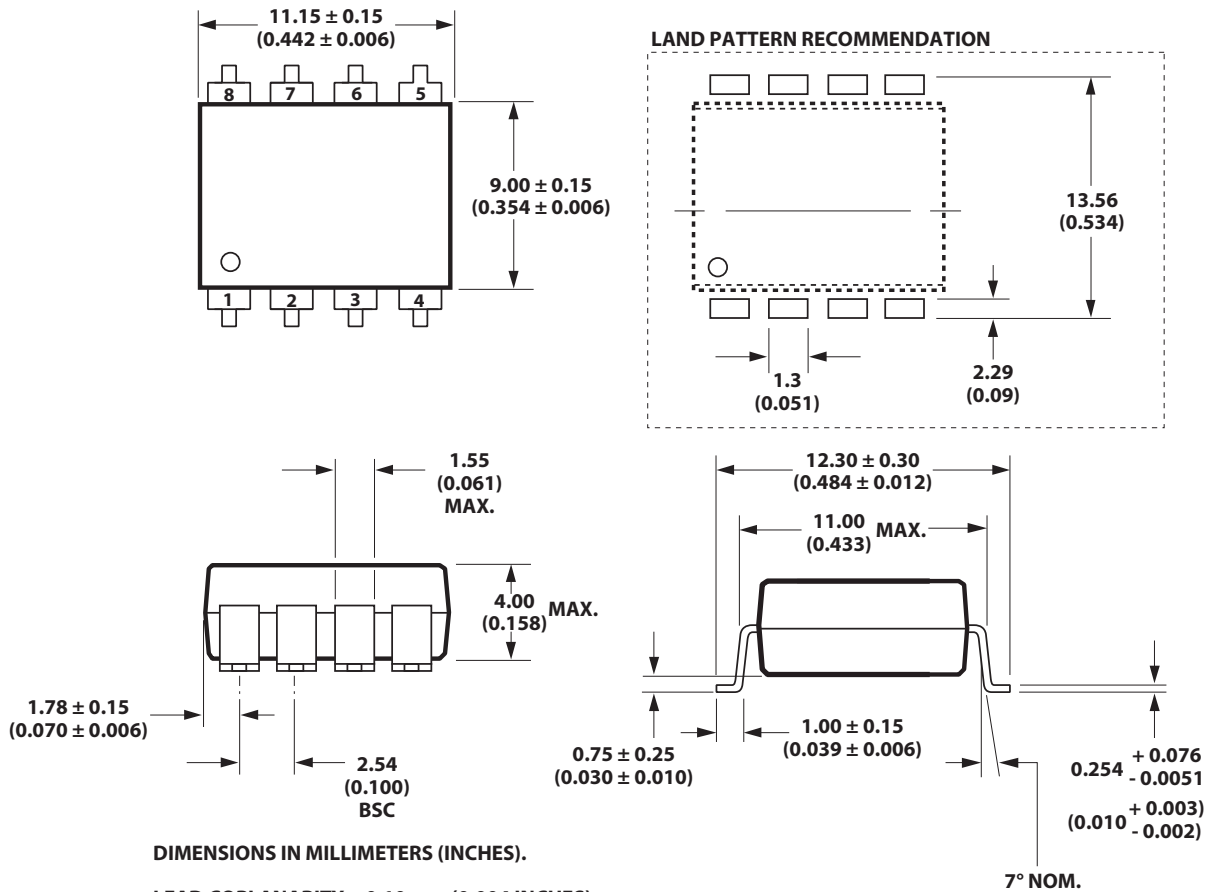

DIMENSIONS IN MILLIMETERS (INCHES).

LEAD COPLANARITY = 0.10 mm (0.004 INCHES).

NOTE: FLOATING LEAD PROTRUSION IS 0.25 mm (10 mils) MAX.

## Solder Reflow Profile

The recommended reflow soldering conditions are per JEDEC Standard J-STD-020 (latest revision). Non-halide flux should be used.

## Regulatory Information

The HCNR200/201 optocoupler features a 0.400-in. wide, eight-pin DIP package. This package was specifically designed to meet worldwide regulatory requirements. The HCNR200/201 has been approved by the following organizations.

<b>UL</b>	Recognized under UL 1577, Component Recognition Program, FILE E55361.
<b>IEC/EN/DIN EN 60747-5-5</b>	
<b>CSA</b>	Approved under CSA Component Acceptance Notice #5, File CA 88324

## Insulation and Safety-Related Specifications

Parameter	Symbol	Value	Units	Conditions
Min. External Clearance (External Air Gap)	L(IO1)	9.6	mm	Measured from input terminals to output terminals, shortest distance through air
Min. External Creepage (External Tracking Path)	L(IO2)	10.0	mm	Measured from input terminals to output terminals, shortest distance path along body
Min. Internal Clearance (Internal Plastic Gap)		1.0	mm	Through insulation distance conductor to conductor, usually the direct distance between the photoemitter and photodetector inside the optocoupler cavity
Min. Internal Creepage (Internal Tracking Path)		4.0	mm	The shortest distance around the border between two different insulating materials measured between the emitter and detector
Comparative Tracking Index	CTI	200	V	DIN IEC 112/VDE 0303 PART 1
Isolation Group		IIIa		Material group (DIN VDE 0110)

**NOTE:** Option 300 – surface mount classification is Class A in accordance with CECC 00802.

## IEC/EN/DIN EN 60747-5-5 Insulation Characteristics (Option -050E/-350E/-550E Only)

Description	Symbol	Characteristic	Units
Installation classification per DIN VDE 0110, Table 1 For rated mains voltage $\leq 600$ V rms For rated mains voltage $\leq 1000$ V rms		I-IV I-III	
Climatic Classification		40/85/21	
Pollution Degree (DIN VDE 0110/39)		2	
Maximum Working Insulation Voltage	$V_{IORM}$	1414	$V_{peak}$
Input to Output Test Voltage, Method b <sup>a</sup> $V_{PR} = 1.875 \times V_{IORM}$ , 100% Production Test with $t_m = 1$ s, Partial Discharge $< 5$ pC	$V_{PR}$	2651	$V_{peak}$
Input to Output Test Voltage, Method a <sup>a</sup> $V_{PR} = 1.6 \times V_{IORM}$ , Type and sample test, $t_m = 10$ s, Partial Discharge $< 5$ pC	$V_{PR}$	2262	$V_{peak}$
Highest Allowable Overvoltage <sup>a</sup> (Transient Overvoltage, $t_{ini} = 60$ s)	$V_{IOTM}$	8000	$V_{peak}$
Safety-Limiting Values (Maximum values allowed in the event of a failure)			
Case Temperature	$T_S$	150	$^{\circ}\text{C}$
Current (Input Current $I_F$ , $P_S = 0$ )	$I_S$	400	mA
Output Power	$P_{S,OUTPUT}$	700	mW
Insulation Resistance at $T_S$ , $V_{IO} = 500$ V	$R_S$	$> 10^9$	$\Omega$

a. Refer to the front of the Optocoupler section of the current catalog for a more detailed description of IEC/EN/DIN EN 60747-5-5 and other product safety regulations.

**NOTE:** Optocouplers providing safe electrical separation per IEC/EN/DIN EN 60747-5-5 do so only within the safety-limiting values to which they are qualified. Protective cut-out switches must be used to ensure that the safety limits are not exceeded.

## Absolute Maximum Ratings

Description	Rating
Storage Temperature	$-55^{\circ}\text{C}$ to $+125^{\circ}\text{C}$
Operating Temperature ( $T_A$ )	$-55^{\circ}\text{C}$ to $+100^{\circ}\text{C}$
Junction Temperature ( $T_J$ )	$125^{\circ}\text{C}$
Reflow Temperature Profile	See <a href="#">Package Outline Drawings</a>
Lead Solder Temperature (up to seating plane)	$260^{\circ}\text{C}$ for 10s
Average Input Current – $I_F$	25 mA
Peak Input Current – $I_F$ (50 ns maximum pulse width)	40 mA
Reverse Input Voltage – $V_R$ ( $I_R = 100$ $\mu\text{A}$ , Pins 1 to 2)	2.5V
Input Power Dissipation (Derate at $2.2$ mW/ $^{\circ}\text{C}$ for operating temperatures above $85^{\circ}\text{C}$ )	60 mW at $T_A = 85^{\circ}\text{C}$
Reverse Output Photodiode Voltage (Pins 6 to 5)	30V
Reverse Input Photodiode Voltage (Pins 3 to 4)	30V

## Recommended Operating Conditions

Description	Condition
Storage Temperature	-40°C to +85°C
Operating Temperature	-40°C to +85°C
Average Input Current – $I_F$	1 mA to 20 mA
Peak Input Current – $I_F$ (50% duty cycle, 1-ms pulse width)	35 mA
Reverse Output Photodiode Voltage (Pins 6 to 5)	0 to 15V
Reverse Input Photodiode Voltage (Pins 3 to 4)	0 to 15V

## Electrical Specifications

$T_A = 25^\circ\text{C}$  unless otherwise specified.

Parameter	Symbol	Device	Min.	Typ.	Max.	Units	Test Conditions	Figure	Note
Transfer Gain	$K_3$	HCNR200	0.85	1.00	1.15		5 nA < $I_{PD}$ < 50 $\mu\text{A}$ , 0V < $V_{PD}$ < 15V	3, 4	a
		HCNR201	0.95	1.00	1.05		5 nA < $I_{PD}$ < 50 $\mu\text{A}$ , 0V < $V_{PD}$ < 15V		a
		HCNR201	0.93	1.00	1.07		-40°C < $T_A$ < 85°C, 5 nA < $I_{PD}$ < 50 $\mu\text{A}$ , 0V < $V_{PD}$ < 15V		a
Temperature Coefficient of Transfer Gain	$\Delta K_3/\Delta T_A$		—	-65	—	ppm/°C	-40°C < $T_A$ < 85°C, 5 nA < $I_{PD}$ < 50 $\mu\text{A}$ , 0V < $V_{PD}$ < 15V	3, 4	
DC Nonlinearity (Best Fit)	$NL_{BF}$	HCNR200	—	0.01	0.25	%	5 nA < $I_{PD}$ < 50 $\mu\text{A}$ , 0V < $V_{PD}$ < 15V	5, 6, 7	b
		HCNR201	—	0.01	0.05		5 nA < $I_{PD}$ < 50 $\mu\text{A}$ , 0V < $V_{PD}$ < 15V		b
		HCNR201	—	0.01	0.07		-40°C < $T_A$ < 85°C, 5 nA < $I_{PD}$ < 50 $\mu\text{A}$ , 0V < $V_{PD}$ < 15V		b
DC Nonlinearity (Ends Fit)	$NL_{EF}$		—	0.016	—	%	5 nA < $I_{PD}$ < 50 $\mu\text{A}$ , 0V < $V_{PD}$ < 15V		c
Input Photodiode Current Transfer Ratio ( $I_{PD1}/I_F$ )	$K_1$	HCNR200	0.25	0.50	0.75	%	$I_F = 10 \text{ mA}$ , 0V < $V_{PD1}$ < 15V	8	
		HCNR201	0.36	0.48	0.72				
Temperature Coefficient of $K_1$	$\Delta K_1/\Delta T_A$		—	-0.3	—	%/°C	-40°C < $T_A$ < 85°C, $I_F = 10 \text{ mA}$ , 0V < $V_{PD1}$ < 15V	8	
Photodiode Leakage Current	$I_{LK}$		—	0.5	25	nA	$I_F = 0 \text{ mA}$ , 0V < $V_{PD}$ < 15V	9	
Photodiode Reverse Breakdown Voltage	$BV_{RPD}$		30	150	—	V	$I_R = 100 \mu\text{A}$		
Photodiode Capacitance	$C_{PD}$		—	22	—	pF	$V_{PD} = 0\text{V}$		

Parameter	Symbol	Device	Min.	Typ.	Max.	Units	Test Conditions	Figure	Note
LED Forward Voltage	$V_F$		1.3	1.6	1.85	V	$I_F = 10 \text{ mA}$	10, 11	
			1.2	1.6	1.95		$I_F = 10 \text{ mA}$ , $-40^\circ\text{C} < T_A < 85^\circ\text{C}$		
LED Reverse Breakdown Voltage	$BV_R$		2.5	9	—	V	$I_F = 100 \mu\text{A}$		
Temperature Coefficient of Forward Voltage	$\Delta V_F / \Delta T_A$		—	-1.7	—	mV/°C	$I_F = 10 \text{ mA}$		
LED Junction Capacitance	$C_{LED}$		—	80	—	pF	$f = 1 \text{ MHz}$ , $V_F = 0\text{V}$		

- $K_3$  is calculated from the slope of the best fit line of  $I_{PD2}$  vs.  $I_{PD1}$  with eleven equally distributed data points from 5 nA to 50  $\mu\text{A}$ . This is approximately equal to  $I_{PD2}/I_{PD1}$  at  $I_F = 10 \text{ mA}$ .
- BEST FIT DC NONLINEARITY ( $NL_{BF}$ ) is the maximum deviation expressed as a percentage of the full scale output of a “best fit” straight line from a graph of  $I_{PD2}$  vs.  $I_{PD1}$  with eleven equally distributed data points from 5 nA to 50  $\mu\text{A}$ .  $I_{PD2}$  error to best fit line is the deviation below and above the best fit line, expressed as a percentage of the full scale output.
- ENDS FIT DC NONLINEARITY ( $NL_{EF}$ ) is the maximum deviation expressed as a percentage of full scale output of a straight line from the 5 nA to the 50  $\mu\text{A}$  data point on the graph of  $I_{PD2}$  vs.  $I_{PD1}$ .

## AC Electrical Specifications

$T_A = 25^\circ\text{C}$  unless otherwise specified.

Parameter	Symbol	Device	Min.	Typ.	Max.	Units	Test Conditions	Figure	Note
LED Bandwidth	$f - 3 \text{ dB}$		—	9	—	MHz	$I_F = 10 \text{ mA}$		
Application Circuit Bandwidth			—	1.5	—	MHz		17	a
				High Speed	10				
Application Circuit: IMRR High Speed			—	95	—	dB	freq = 60 Hz	17	a, b

- Specific performance will depend on circuit topology and components.
- IMRR is defined as the ratio of the signal gain (with signal applied to  $V_{IN}$  of Figure 17) to the isolation mode gain (with  $V_{IN}$  connected to input common and the signal applied between the input and output commons) at 60 Hz, expressed in dB.

## Package Characteristics

$T_A = 25^\circ\text{C}$  unless otherwise specified.

Parameter	Symbol	Device	Min.	Typ.	Max.	Units	Test Conditions	Figure	Note
Input-Output Momentary-Withstand Voltage <sup>a</sup>	$V_{ISO}$		5000	—	—	V rms	RH $\leq$ 50%, t = 1 min.		b, c
Resistance (Input-Output)	$R_{I-O}$		$10^{12}$	$10^{13}$	—	$\Omega$	$V_O = 500$ VDC		b
			$10^{11}$	—	—		$T_A = 100^\circ\text{C}$ , $V_{IO} = 500$ VDC		b
Capacitance (Input-Output)	$C_{I-O}$		—	0.4	0.6	pF	f = 1 MHz		b

- a. The Input-Output Momentary-Withstand Voltage is a dielectric voltage rating that should not be interpreted as an input-output continuous voltage rating. For the continuous voltage rating, refer to the VDE 0884 Insulation Characteristics Table (if applicable), your equipment level safety specification, or Application Note 1074, *Optocoupler Input-Output Endurance Voltage*.
- b. The device considered a two-terminal device: Pins 1, 2, 3, and 4 shorted together and pins 5, 6, 7, and 8 shorted together.
- c. In accordance with UL 1577, each optocoupler is proof tested by applying an insulation test voltage of  $\geq 6000$  V rms for  $\geq 1$  second (leakage detection current limit, I<sub>I-O</sub> of 5  $\mu\text{A}$  max.). This test is performed before the 100% production test for partial discharge (method b) shown in the IEC/EN/DIN EN 60747-5-5 Insulation Characteristics Table (for Option -050E/-350E/-550E only).

Figure 3: Normalized K3 vs. Input  $I_{PD}$

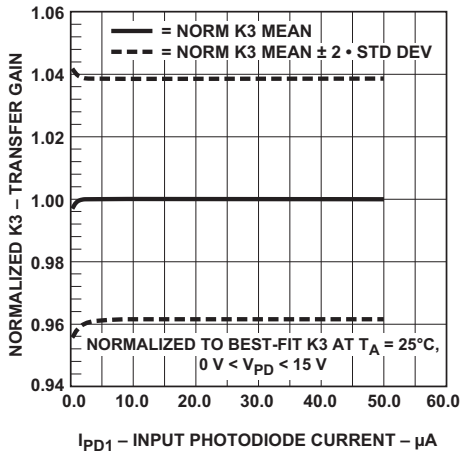

Figure 4: K3 Drift vs. Temperature

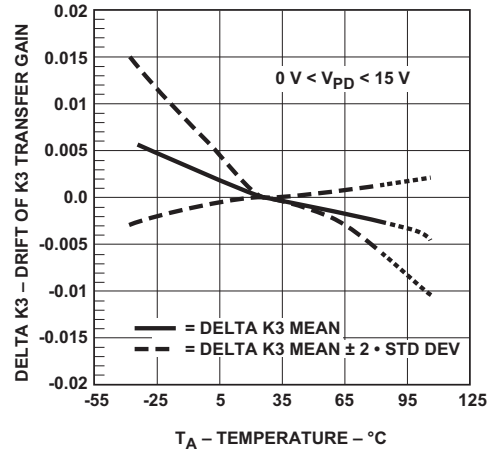

Figure 5:  $I_{PD2}$  Error vs. Input  $I_{PD}$  (see note b)

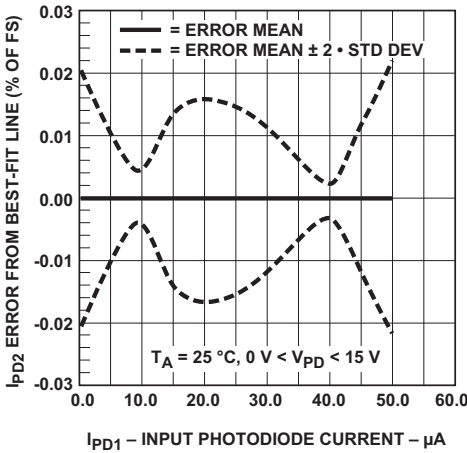

Figure 6:  $NL_{BF}$  vs. Temperature

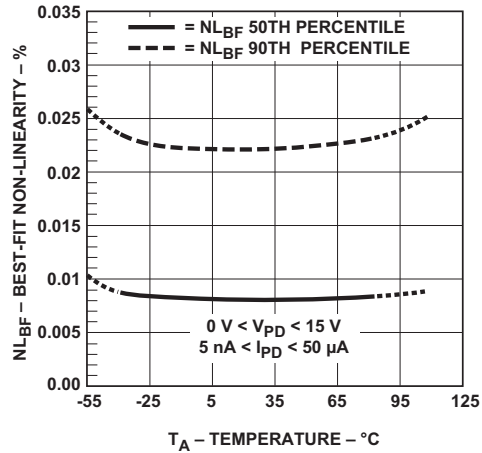

Figure 7:  $NL_{BF}$  Drift vs. Temperature

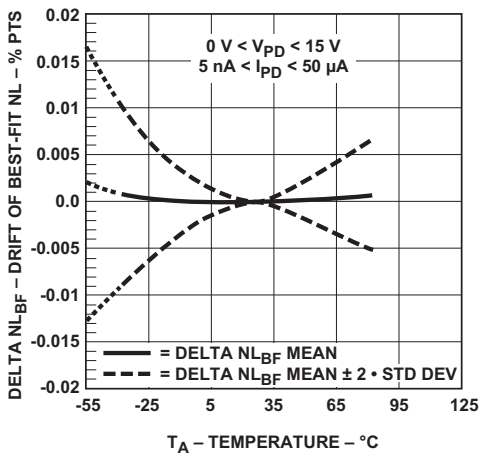

Figure 8: Input Photodiode CTR vs. LED Input Current

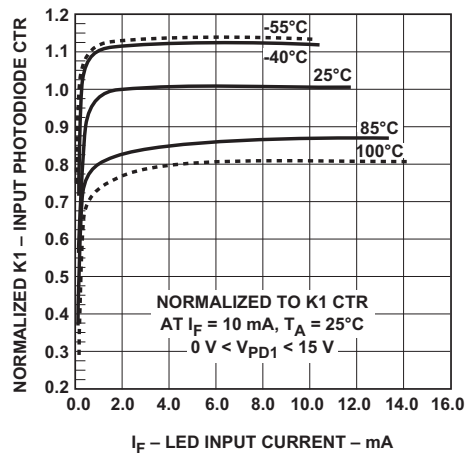

Figure 9: Typical Photodiode Leakage vs. Temperature

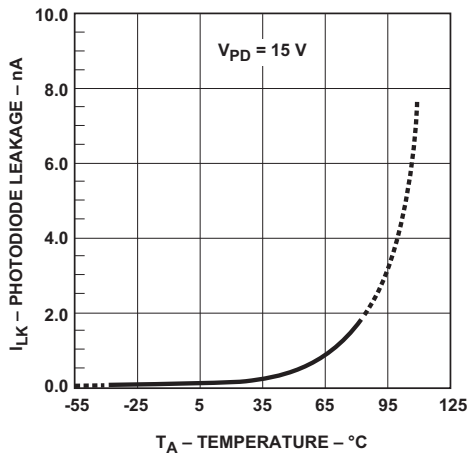

Figure 10: LED Input Current vs. Forward Voltage

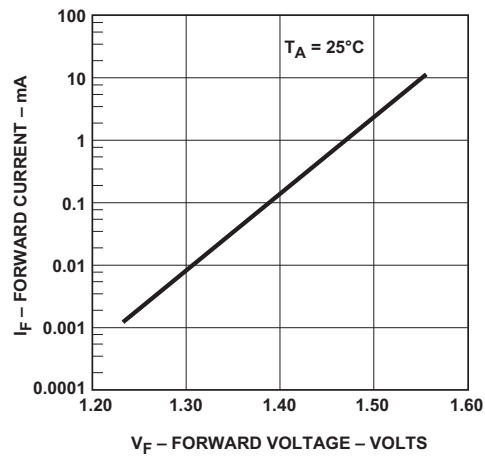

Figure 11: LED Forward Voltage vs. Temperature

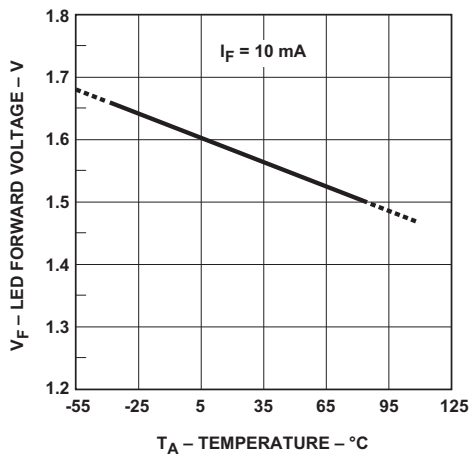

Figure 12: Thermal Derating Curve Dependence of Safety-Limiting Value with Case Temperature per IEC/EN/DIN EN 60747-5-5

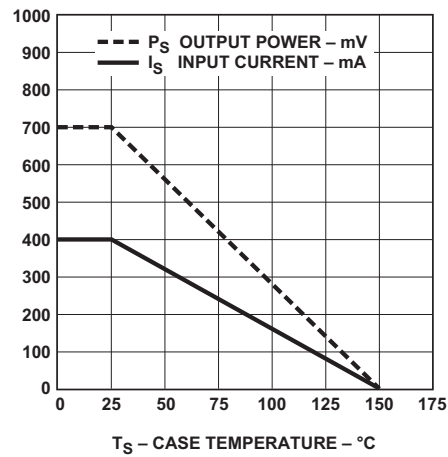

Figure 13: Basic Isolation Amplifier

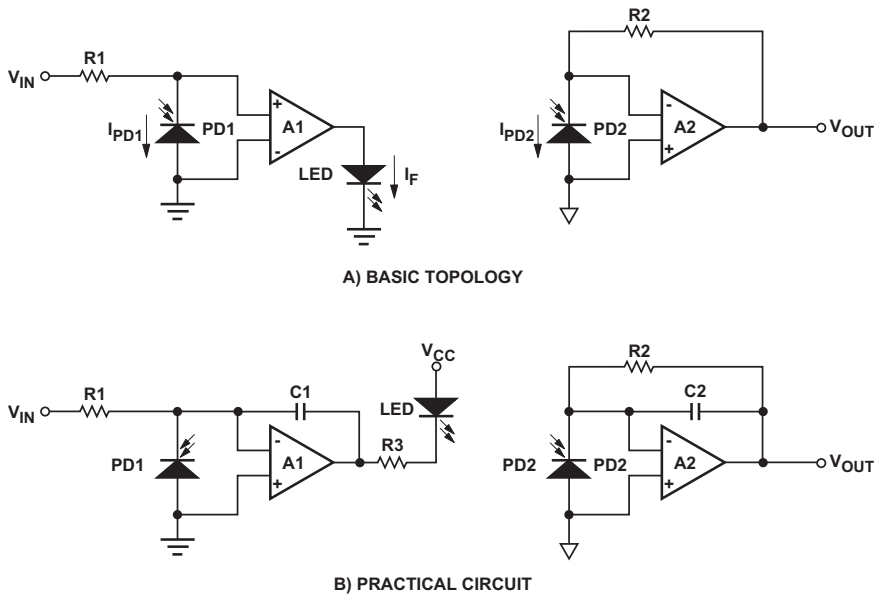

Figure 14: Unipolar Circuit Topologies

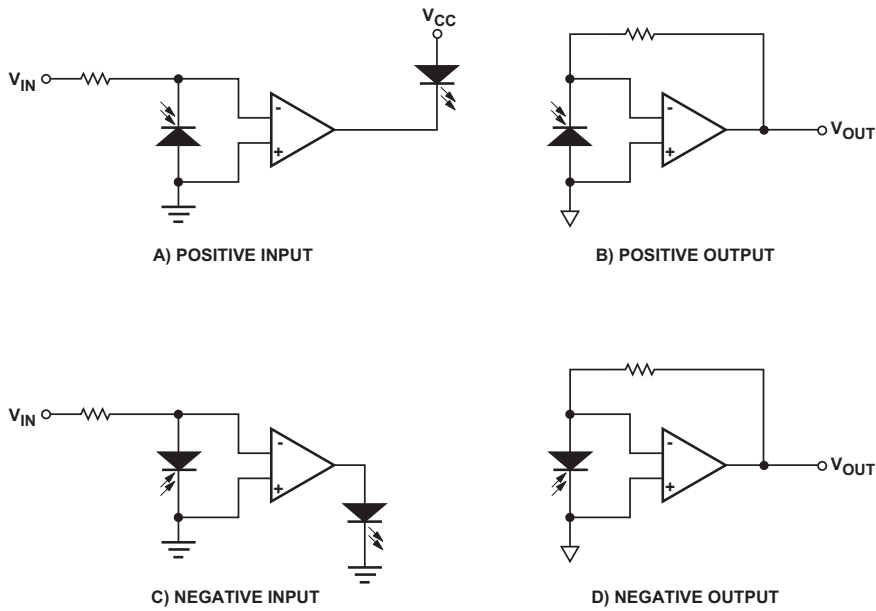

Figure 15: Bipolar Circuit Topologies

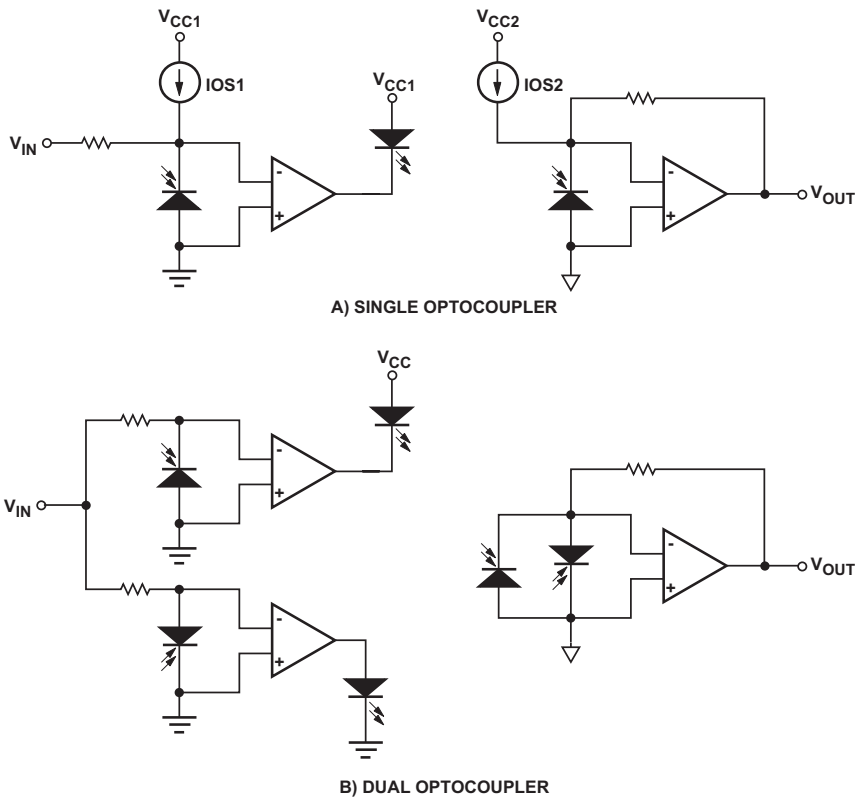

Figure 16: Loop-Powered 4 mA to 20 mA Current Loop Circuits

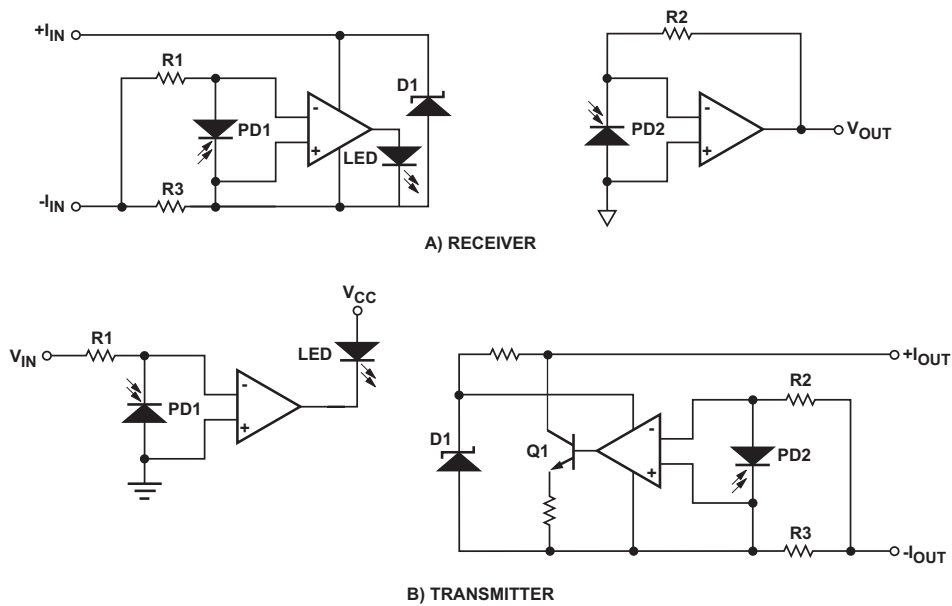

Figure 17: High-Speed Low-Cost Analog Isolator

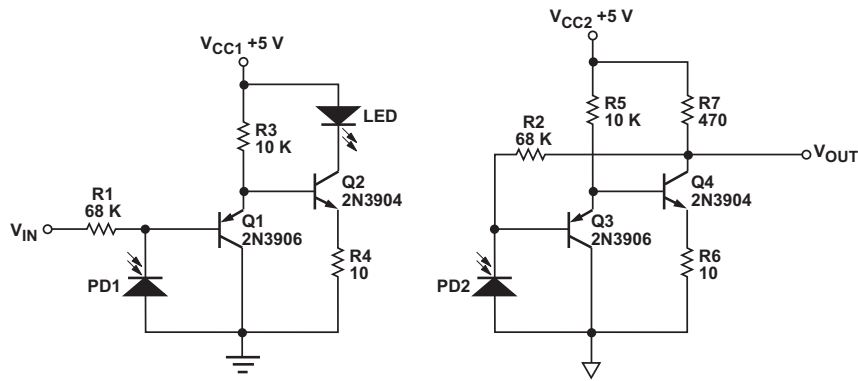

Figure 18: Precision Analog Isolation Amplifier

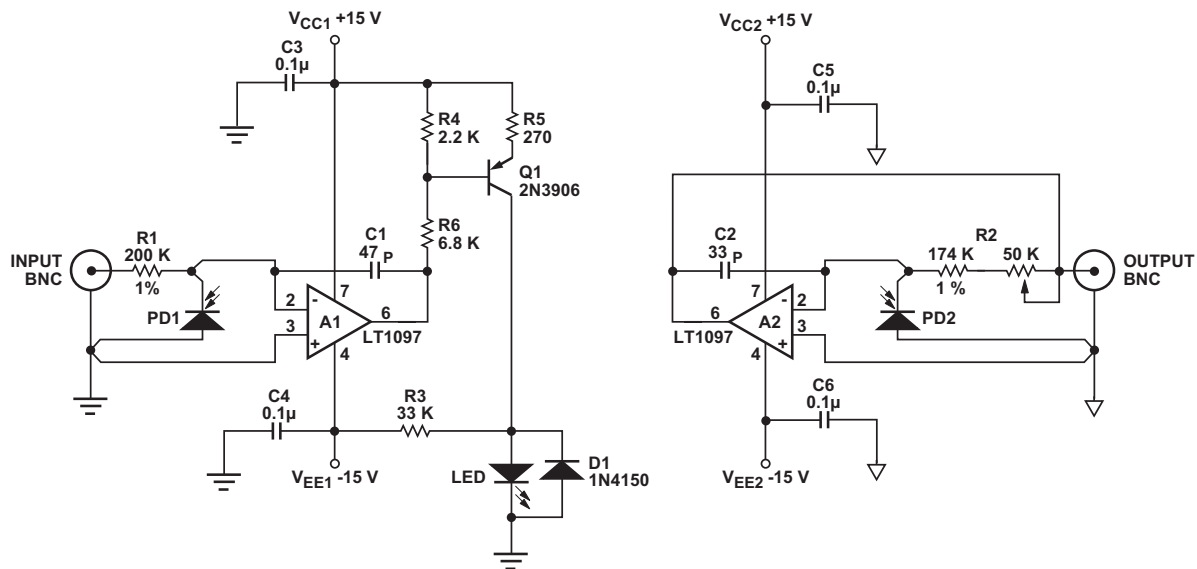

Figure 19: Bipolar Isolation Amplifier

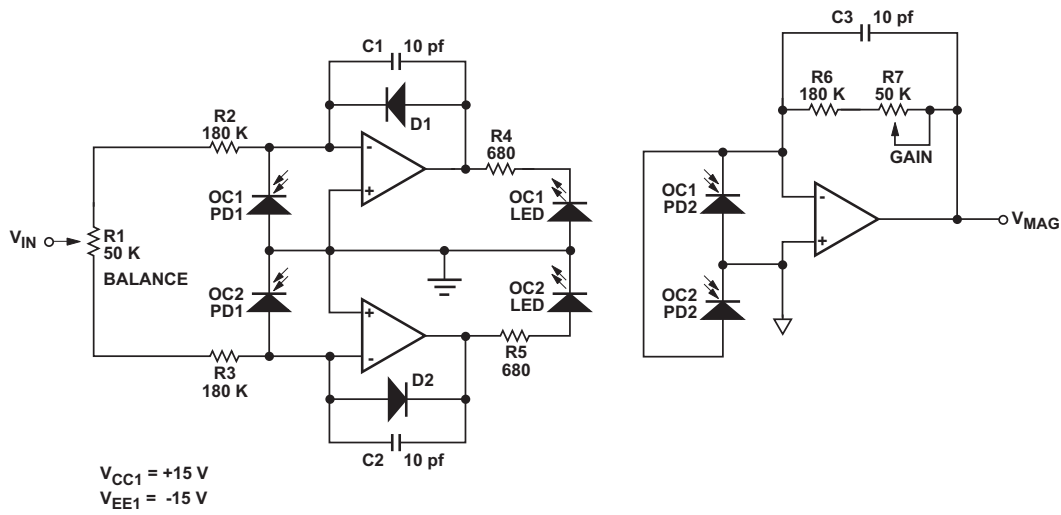

Figure 20: Magnitude/Sign Isolation Amplifier

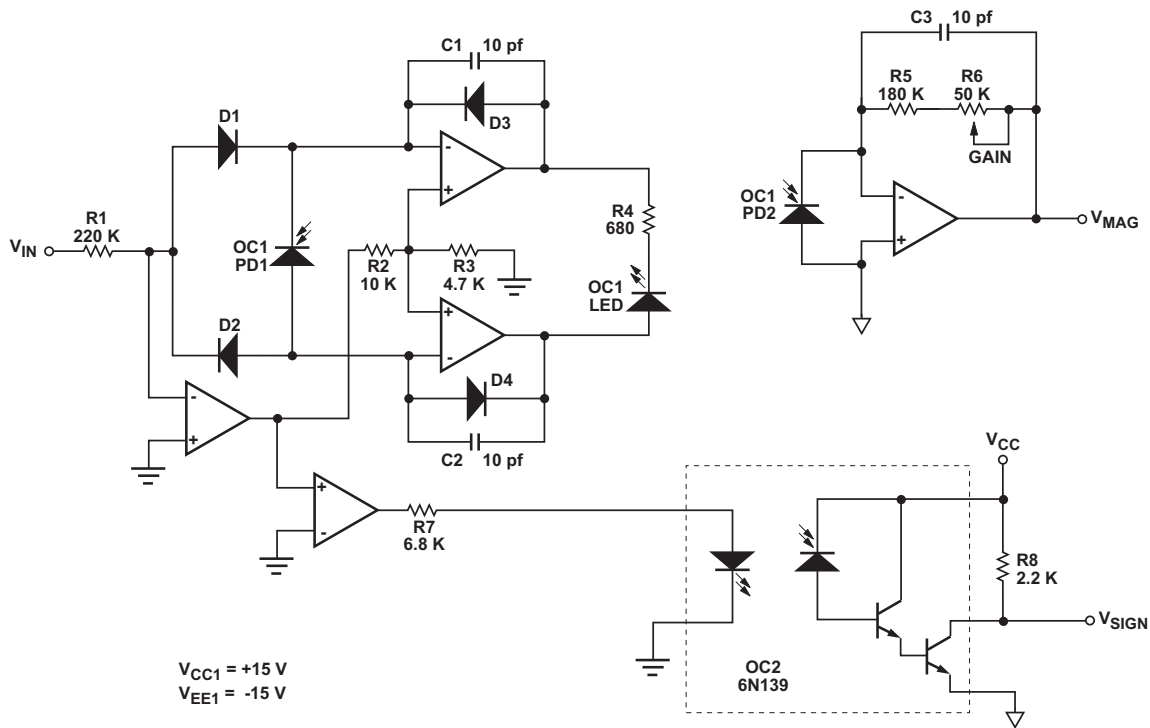

Figure 21: SPICE Model Listing

```

*HCNR200 Linear Optocoupler SPICE Model
*
*      LED Cathode
*      |
*      LED Anode
*      |
*      PD1 Cathode
*      |
*      PD1 Anode
*      |
*      PD2 Anode
*      |
*      PD2 Cathode
*
.SUBCKT HCNR200 1 2 3 4 5 6

* LED circuit
QLED1 8 2 7 QCPL .5
QLED2 9 2 7 QCPL .5
VLED 7 1 DC .685
VPD1 8 1 DC 2
VPD2 9 1 DC 2

* Input photodiode circuit
DPD1 4 3 DPHOTO
FPD1 3 4 VPD1 -1
CPD1 4 3 8P

* Output photodiode circuit
DPD2 5 6 DPHOTO
FPD2 6 5 VPD2 -1
CPD2 5 6 8P

* Photodiode model
.MODEL DPHOTO D(IS=4.5E-12 RS=150 N=1.3 XTI=4 EG=1.11
+ CJO=14P M=1.96 VJ=1.9)

* LED/Optical-coupling transistor model
.model QCPL NPN(IS=2.214E-19 BF=10m NF=1.010 IKF=11.00m ISE=1.167P
+ NE=1.737 RB=3.469 VAF=100 TF=1.77U CJE=80P)

.ENDS

```

Figure 22: 4 mA to 20 mA HCNR200 Receiver Circuit

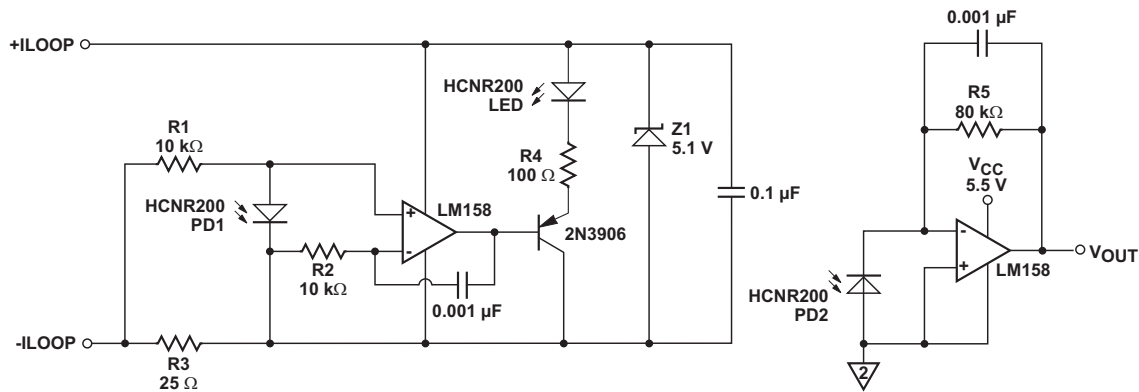

Design Equations:

$$(V_{OUT} / I_{LOOP}) = K_3 (R_5 R_3) / (R_1 + R_3)$$

$$K_3 = K_2 / K_1 = \text{Constant} = 1$$

**NOTE:** The two OP-AMPS shown are two separate LM158 ICs, and *not* two channels in a dual package; otherwise, the LOOP side and the output side will not be properly isolated.

Figure 23: 4 mA to 20 mA HCNR200 Transmitter Circuit

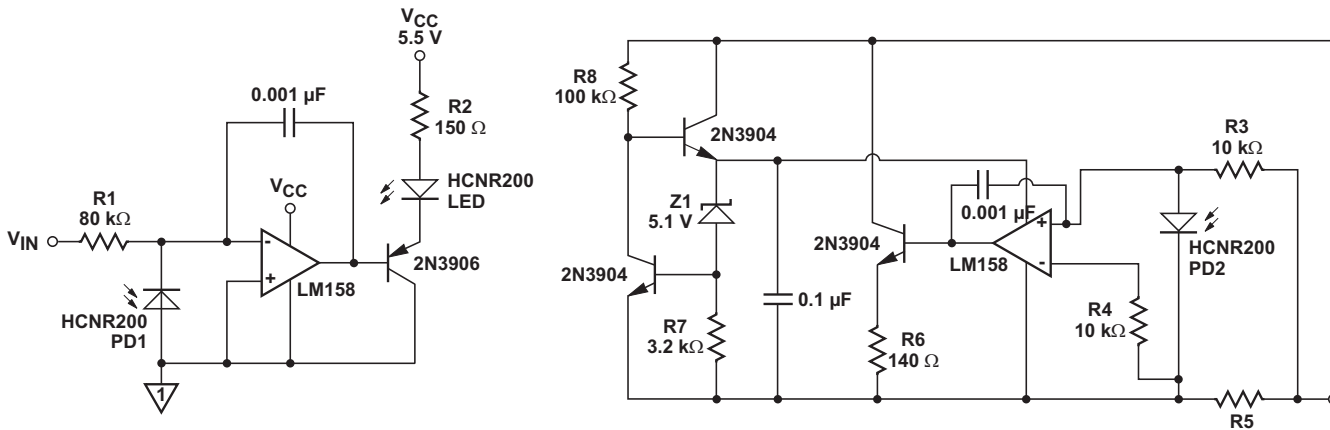

Design Equations:

$$(I_{LOOP} / V_{in}) = K_3 (R_5 + R_3) / (R_5 R_1)$$

$$K_3 = K_2 / K_1 = \text{Constant} \approx 1$$

**NOTE:** The two OP-AMPS shown are two separate LM158 ICs, and *not* dual channels in a single package; otherwise, the LOOP side and input side will not be properly isolated. The 5V1 Zener should be properly selected to ensure that it conducts at 187 μA.

## Theory of Operation

Figure 1 shows how the HCNR200/201 high-linearity optocoupler is configured. The basic optocoupler consists of an LED and two photodiodes. The LED and one of the photodiodes (PD1) is on the input leadframe and the other photodiode (PD2) is on the output leadframe. The package of the optocoupler is constructed so that each photodiode receives approximately the same amount of light from the LED.

An external feedback amplifier can be used with PD1 to monitor the light output of the LED and automatically adjust the LED current to compensate for any nonlinearities or changes in light output of the LED. The feedback amplifier acts to stabilize and linearize the light output of the LED. The output photodiode then converts the stable, linear light output of the LED into a current, which can then be converted back into a voltage by another amplifier.

Figure 13a illustrates the basic circuit topology for implementing a simple isolation amplifier using the HCNR200/201 optocoupler. Besides the optocoupler, two external op-amps and two resistors are required. This circuit is actually a bit too simple to function properly in an actual circuit, but it is quite useful for explaining how the basic isolation amplifier circuit works (a few more components and a circuit change are required to make a practical circuit, like the one shown in Figure 13b).

The operation of the basic circuit may not be immediately obvious just from inspecting Figure 13a, particularly the input part of the circuit. Stated briefly, amplifier A1 adjusts the LED current ( $I_F$ ), and therefore the current in PD1 ( $I_{PD1}$ ), to maintain its “+” input terminal at 0V. For example, increasing the input voltage would tend to increase the voltage of the “+” input terminal of A1 above 0V. A1 amplifies that increase, causing  $I_F$  to increase, as well as  $I_{PD1}$ . Because of the way that PD1 is connected,  $I_{PD1}$  pulls the “+” terminal of the op-amp back toward ground. A1 continues to increase  $I_F$  until its “+” terminal is back at 0V. Assuming that A1 is a perfect op-amp, no current flows into the inputs of A1; therefore, all of the current flowing through R1 will flow through PD1. Because the “+” input of A1 is at 0V, the current through R1, and therefore  $I_{PD1}$  as well, is equal to  $V_{IN} / R1$ .

Essentially, amplifier A1 adjusts  $I_F$  so that

$$I_{PD1} = V_{IN} / R1.$$

Notice that  $I_{PD1}$  depends *only* on the input voltage and the value of R1 and is independent of the light output characteristics of the LED. As the light output of the LED changes with temperature, amplifier A1 adjusts  $I_F$  to compensate and maintain a constant current in PD1. Also notice that  $I_{PD1}$  is exactly proportional to  $V_{IN}$ , giving a very linear relationship between the input voltage and the photodiode current.

The relationship between the input optical power and the output current of a photodiode is very linear. Therefore, by stabilizing and linearizing  $I_{PD1}$ , the light output of the LED is also stabilized and linearized. And because light from the LED falls on both of the photodiodes,  $I_{PD2}$  will be stabilized as well.

The physical construction of the package determines the relative amounts of light that fall on the two photodiodes and, therefore, the ratio of the photodiode currents. This results in very stable operation over time and temperature. The photodiode current ratio can be expressed as a constant, K, where

$$K = I_{PD2} / I_{PD1}$$

Amplifier A2 and resistor R2 form a trans-resistance amplifier that converts  $I_{PD2}$  back into a voltage,  $V_{OUT}$ , where

$$V_{OUT} = I_{PD2} \times R2$$

Combining the above three equations yields an overall expression relating the output voltage to the input voltage:

$$V_{OUT} / V_{IN} = K \times (R2 / R1)$$

Therefore the relationship between  $V_{IN}$  and  $V_{OUT}$  is constant, linear, and independent of the light output characteristics of the LED. The gain of the basic isolation amplifier circuit can be adjusted simply by adjusting the ratio of R2 to R1. The parameter K (called  $K_3$  in the electrical specifications) can be thought of as the gain of the optocoupler and is specified in the data sheet.

Remember, the circuit in Figure 13a is simplified to explain the basic circuit operation. A practical circuit, more like Figure 13b, will require a few additional components to stabilize the input part of the circuit, to limit the LED current, or to optimize circuit performance. Example application circuits will be described later in the data sheet.

## Circuit Design Flexibility

Circuit design with the HCNR200/201 is very flexible because the LED and both photodiodes are accessible to the designer. This allows the designer to make performance trade-offs that would otherwise be difficult to make with commercially available isolation amplifiers (for example, bandwidth vs. accuracy vs. cost). Analog isolation circuits can be designed for applications that have either unipolar (for example, 0V to 10V) or bipolar (for example,  $\pm 10V$ ) signals, with positive or negative input or output voltages. Several simplified circuit topologies illustrating the design flexibility of the HCNR200/201 are in this section.

The circuit in [Figure 13a](#) is configured to be non-inverting with positive input and output voltages. By changing the polarity of one or both of the photodiodes, the LED, or the op-amp inputs, it is possible to implement other circuit configurations as well. [Figure 14](#) shows how to change the basic circuit to accommodate both positive and negative input and output voltages. The input and output circuits can be matched to achieve any combination of positive and negative voltages, allowing for both inverting and non-inverting circuits.

All of the configurations described previously are unipolar (single polarity); the circuits cannot accommodate a signal that might swing both positive and negative. It is possible, however, to use the HCNR200/201 optocoupler to implement a bipolar isolation amplifier. Two topologies that allow for bipolar operation are shown in [Figure 15](#).

The circuit in [Figure 15a](#) uses two current sources to offset the signal so that it appears to be unipolar to the optocoupler. Current source  $I_{OS1}$  provides enough offset to ensure that  $I_{PD1}$  is always positive. The second current source,  $I_{OS2}$ , provides an offset of opposite polarity to obtain a net circuit offset of zero. Current sources  $I_{OS1}$  and  $I_{OS2}$  can be implemented simply as resistors connected to suitable voltage sources.

The circuit in [Figure 15b](#) uses two optocouplers to obtain bipolar operation. The first optocoupler handles the positive voltage excursions, while the second optocoupler handles the negative ones. The output photodiodes are connected in an antiparallel configuration so that they produce output signals of opposite polarity.

The first circuit has the obvious advantage of requiring only one optocoupler; however, the offset performance of the circuit is dependent on the matching of  $I_{OS1}$  and  $I_{OS2}$  and is also dependent on the gain of the optocoupler. Changes in the gain of the optocoupler directly affect the offset of the circuit.

The offset performance of the second circuit, on the other hand, is much more stable; it is independent of optocoupler gain and has no matched current sources to worry about. However, the second circuit requires two optocouplers, separate gain adjustments for the positive and negative portions of the signal, and can exhibit crossover distortion near 0V. The correct circuit to choose for an application would depend on the requirements of that particular application. As with the basic isolation amplifier circuit in [Figure 13a](#), the circuits in [Figure 15](#) are simplified and would require a few additional components to function properly. Two example circuits that operate with bipolar input signals are described in the next section.

As a final example of circuit design flexibility, the simplified schematics in [Figure 16](#) illustrate how to implement 4 mA to 20 mA analog current-loop transmitter and receiver circuits using the HCNR200/201 optocoupler. In these circuits, the loop side of the circuit is powered entirely by the loop current, eliminating the need for an isolated power supply.

The input and output circuits in [Figure 16a](#) are the same as the negative input and positive output circuits shown in [Figure 14c](#) and [Figure 14b](#), except for the addition of R3 and zener diode D1 on the input side of the circuit. D1 regulates the supply voltage for the input amplifier, while R3 forms a current divider with R1 to scale the loop current down from 20 mA to an appropriate level for the input circuit ( $<50 \mu A$ ).

As in the simpler circuits, the input amplifier adjusts the LED current so that both of its input terminals are at the same voltage. The loop current is then divided between R1 and R3.  $I_{PD1}$  is equal to the current in R1 and is given by the following equation:

$$I_{PD1} = I_{LOOP} \times R3 / (R1 + R3)$$

Combining the above equation with the equations used for [Figure 13a](#) yields an overall expression relating the output voltage to the loop current:

$$V_{OUT} / I_{LOOP} = K \times (R2 \times R3) / (R1 + R3)$$

Again, you can see that the relationship is constant, linear, and independent of the characteristics of the LED.

The 4 mA to 20 mA transmitter circuit in [Figure 16b](#) is a little different from the previous circuits, particularly the output circuit. The output circuit does not directly generate an output voltage that is sensed by R2; it instead uses Q1 to generate an output current that flows through R3. This output current generates a voltage across R3, which is then sensed by R2. An analysis similar to the one above yields the following expression relating output current to input voltage:

$$I_{\text{LOOP}} / V_{\text{IN}} = K \times (R2 + R3) / (R1 \times R3)$$

The preceding circuits were presented to illustrate the flexibility in designing analog isolation circuits using the HCNR200/201. The next section presents several complete schematics to illustrate practical applications of the HCNR200/201.

## Example Application Circuits

The circuit shown in [Figure 17](#) is a high-speed low-cost circuit designed for use in the feedback path of switch-mode power supplies. This application requires good bandwidth, low cost and stable gain, but does not require very high accuracy. This circuit is a good example of how a designer can trade off accuracy to achieve improvements in bandwidth and cost. The circuit has a bandwidth of about 1.5 MHz with stable gain characteristics and requires few external components.

Although it may not appear so at first glance, the circuit in [Figure 17](#) is essentially the same as the circuit in [Figure 13a](#). Amplifier A1 is comprised of Q1, Q2, R3, and R4, while amplifier A2 is comprised of Q3, Q4, R5, R6, and R7. The circuit operates in the same manner as well; the only difference is the performance of amplifiers A1 and A2. The lower gains, higher input currents and higher offset voltages affect the accuracy of the circuit, but not the way it operates. Because the basic circuit operation has not changed, the circuit still has good gain stability. The use of discrete transistors instead of op-amps allowed the design to trade off accuracy to achieve good bandwidth and gain stability at low cost.

To get into a little more detail about the circuit, R1 is selected to achieve an LED current of about 7 mA to 10 mA at the nominal input operating voltage according to the following equation:

$$I_F = (V_{\text{IN}} / R1) / K1$$

where K1 (that is,  $I_{\text{PD1}} / I_F$ ) of the optocoupler is typically about 0.5%. R2 is then selected to achieve the desired output voltage according to the equation:

$$V_{\text{OUT}} / V_{\text{IN}} = R2 / R1$$

R4 and R6 improve the dynamic response (that is, stability) of the input and output circuits by lowering the local loop gains. R3 and R5 are selected to provide enough current to drive the bases of Q2 and Q4. R7 is selected so that Q4 operates at about the same collector current as Q2.

The next circuit, shown in [Figure 18](#), is designed to achieve the highest possible accuracy at a reasonable cost. The high accuracy and wide dynamic range of the circuit is achieved by using low-cost precision op-amps with very low input bias currents and offset voltages and is limited by the performance of the optocoupler. The circuit is designed to operate with input and output voltages from 1 mV to 10V.

The circuit operates in the same way as the others. The only major differences are the two compensation capacitors and additional LED drive circuitry. In the high-speed circuit described previously, the input and output circuits are stabilized by reducing the local loop gains of the input and output circuits. Because reducing the loop gains would decrease the accuracy of the circuit, two compensation capacitors, C1 and C2, are instead used to improve circuit stability. These capacitors also limit the bandwidth of the circuit to about 10 kHz and can be used to reduce the output noise of the circuit by reducing its bandwidth even further.

The additional LED drive circuitry (Q1 and R3 through R6) helps to maintain the accuracy and bandwidth of the circuit over the entire range of input voltages. Without these components, the transconductance of the LED driver would decrease at low input voltages and LED currents. This would reduce the loop gain of the input circuit, reducing circuit accuracy and bandwidth. D1 prevents excessive reverse voltage from being applied to the LED when the LED turns off completely.

No offset adjustment of the circuit is necessary; the gain can be adjusted to unity by simply adjusting the 50 k $\Omega$  potentiometer that is part of R2. Any OP-97 type of op-amp can be used in the circuit, such as the LT1097 from Linear Technology or the AD705 from Analog Devices, both of which offer pA bias currents,  $\mu$ V offset voltages and are low cost. The input terminals of the op-amps and the photodiodes are connected in the circuit using Kelvin connections to help ensure the accuracy of the circuit.

The next two circuits illustrate how the HCNR200/201 can be used with bipolar input signals. The isolation amplifier in [Figure 18](#) is a practical implementation of the circuit shown in [Figure 15b](#). It uses two optocouplers, OC1 and OC2; OC1 handles the positive portions of the input signal and OC2 handles the negative portions.

Diodes D1 and D2 help reduce crossover distortion by keeping both amplifiers active during both positive and negative portions of the input signal. For example, when the input signal positive, optocoupler OC1 is active while OC2 is turned off. However, the amplifier controlling OC2 is kept active by D2, allowing it to turn on OC2 more rapidly when the input signal goes negative, thereby reducing crossover distortion.

Balance control R1 adjusts the relative gain for the positive and negative portions of the input signal, gain control R7 adjusts the overall gain of the isolation amplifier, and capacitors C1-C3 provide compensation to stabilize the amplifiers.

The final circuit shown in [Figure 20](#) isolates a bipolar analog signal using only one optocoupler and generates two output signals: an analog signal proportional to the magnitude of the input signal and a digital signal corresponding to the sign of the input signal. This circuit is especially useful for applications where the output of the circuit is applied to an analog-to-digital converter. The primary advantages of this circuit are very good linearity and offset, with only a single gain adjustment and no offset or balance adjustments.

To achieve very high linearity for bipolar signals, the gain should be exactly the same for both positive and negative input polarities. This circuit achieves excellent linearity by using a single optocoupler and a single input resistor, which guarantees identical gain for both positive and negative

polarities of the input signal. This precise matching of gain for both polarities is much more difficult to obtain when separate components are used for the different input polarities, such as is the previous circuit.

The circuit in [Figure 20](#) is actually very similar to the previous circuit. As mentioned previously, only one optocoupler is used. Because a photodiode can conduct current in only one direction, two diodes (D1 and D2) are used to steer the input current to the appropriate terminal of input photodiode PD1 to allow bipolar input currents. Normally, the forward voltage drops of the diodes would cause a serious linearity or accuracy problem. However, an additional amplifier provides an appropriate offset voltage to the other amplifiers that exactly cancels the diode voltage drops to maintain circuit accuracy.

Diodes D3 and D4 perform two different functions; the diodes keep their respective amplifiers active independent of the input signal polarity (as in the previous circuit), and they also provide the feedback signal to PD1 that cancels the voltage drops of diodes D1 and D2.

Either a comparator or an extra op-amp can be used to sense the polarity of the input signal and drive an inexpensive digital optocoupler, such as a 6N139.

It is also possible to convert this circuit into a fully bipolar circuit (with a bipolar output signal) by using the output of the 6N139 to drive some CMOS switches to switch the polarity of PD2 depending on the polarity of the input signal, obtaining a bipolar output voltage swing.

## HCNR200/201 SPICE Model

[Figure 21](#) is the net list of a SPICE macro-model for the HCNR200/201 high-linearity optocoupler. The macro-model accurately reflects the primary characteristics of the HCNR200/201 and should facilitate the design and understanding of circuits using the HCNR200/201 optocoupler.

Copyright © 2014–2023 Broadcom. All Rights Reserved. The term “Broadcom” refers to Broadcom Inc. and/or its subsidiaries. For more information, go to [www.broadcom.com](http://www.broadcom.com). All trademarks, trade names, service marks, and logos referenced herein belong to their respective companies.

Broadcom reserves the right to make changes without further notice to any products or data herein to improve reliability, function, or design. Information furnished by Broadcom is believed to be accurate and reliable. However, Broadcom does not assume any liability arising out of the application or use of this information, nor the application or use of any product or circuit described herein, neither does it convey any license under its patent rights nor the rights of others.

