

## 100 V, 20 A power Schottky rectifier

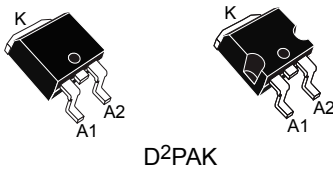
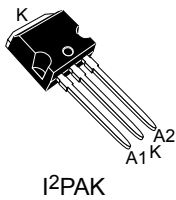
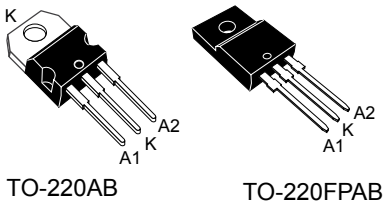
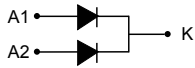

## Features

- Negligible switching losses
- High junction temperature capability
- Low leakage current
- Good trade off between leakage current and forward voltage drop
- Avalanche rated
- Insulated package: TO-220FPAB
  - Insulating voltage = 2000 V<sub>RMS</sub> sine
- ECOPACK<sup>®</sup>2 compliant component for D<sup>2</sup>PAK on demand

## Applications

- Switching diode
- SMPS
- DC/DC converter
- LED lighting
- Adapter for notebook and game station

## Description

Dual center tap Schottky rectifier designed for high frequency miniature switch mode power supplies such as adaptors and on-board DC-DC converters.

## Product status link

[STPS20H100C](#)

## Product summary

|             |          |
|-------------|----------|
| $I_{F(AV)}$ | 2 x 10 A |
| $V_{RRM}$   | 100 V    |
| $T_j$ (max) | 175 °C   |
| $V_F$ (typ) | 0.59 V   |

# 1 Characteristics

**Table 1. Absolute ratings (limiting values, per diode, at 25 °C, unless otherwise specified)**

| Symbol              | Parameter                                             |                                                  |                         | Value        | Unit |   |
|---------------------|-------------------------------------------------------|--------------------------------------------------|-------------------------|--------------|------|---|
| V <sub>RRM</sub>    | Repetitive peak reverse voltage                       |                                                  |                         | 100          | V    |   |
| I <sub>F(RMS)</sub> | Forward rms current                                   |                                                  |                         | 30           | A    |   |
| I <sub>F(AV)</sub>  | Average forward current $\delta = 0.5$ , square wave  | TO-220AB, D <sup>2</sup> PAK, I <sup>2</sup> PAK | T <sub>C</sub> = 160 °C | Per diode    | 10   | A |
|                     |                                                       |                                                  |                         | Per device   | 20   |   |
|                     |                                                       | TO-220FPAB                                       | T <sub>C</sub> = 145 °C | Per diode    | 10   |   |
|                     |                                                       |                                                  | T <sub>C</sub> = 125 °C | Per device   | 20   |   |
| I <sub>FSM</sub>    | Surge non repetitive forward current                  | tp = 10 ms sinusoidal                            |                         | 250          | A    |   |
| P <sub>ARM</sub>    | Repetitive peak avalanche power                       | tp = 10 $\mu$ s, T <sub>J</sub> = 125 °C         |                         | 775          | W    |   |
| T <sub>stg</sub>    | Storage temperature range                             |                                                  |                         | -65 to + 175 | °C   |   |
| T <sub>j</sub>      | Maximum operating junction temperature <sup>(1)</sup> |                                                  |                         | + 175        | °C   |   |

1.  $(dP_{tot}/dT_j) < (1/R_{th(j-a)})$  condition to avoid thermal runaway for a diode on its own heatsink.

**Table 2. Thermal resistance parameter**

| Symbol               | Parameter        |                                                  |           | Value | Unit |
|----------------------|------------------|--------------------------------------------------|-----------|-------|------|
| R <sub>th(j-c)</sub> | Junction to case | TO-220AB, D <sup>2</sup> PAK, I <sup>2</sup> PAK | Per diode | 1.6   | °C/W |
|                      |                  | TO-220FPAB                                       |           | 4     |      |
|                      |                  | TO-220AB, D <sup>2</sup> PAK, I <sup>2</sup> PAK | Total     | 0.9   |      |
|                      |                  | TO-220FPAB                                       |           | 3.2   |      |
| R <sub>th(c)</sub>   | Coupling         | TO-220AB, D <sup>2</sup> PAK, I <sup>2</sup> PAK | -         | 0.15  | °C/W |
|                      |                  | TO-220FPAB                                       |           | 2.5   |      |

When the diodes 1 and 2 are used simultaneously :

$$\Delta T_j(\text{diode 1}) = P(\text{diode 1}) \times R_{th(j-c)}(\text{Per diode}) + P(\text{diode 2}) \times R_{th(c)}$$

For more information, please refer to the following application note :

- AN5088 : Rectifiers thermal management, handling and mounting recommendations

**Table 3. Static electrical characteristics (per diode)**

| Symbol                        | Parameter               | Test conditions         |                                   | Min. | Typ. | Max. | Unit    |
|-------------------------------|-------------------------|-------------------------|-----------------------------------|------|------|------|---------|
| I <sub>R</sub> <sup>(1)</sup> | Reverse leakage current | T <sub>J</sub> = 25 °C  | V <sub>R</sub> = V <sub>RRM</sub> | -    |      | 4.5  | $\mu$ A |
|                               |                         | T <sub>J</sub> = 125 °C |                                   | -    | 2    | 6    | mA      |
| V <sub>F</sub> <sup>(2)</sup> | Forward voltage drop    | T <sub>J</sub> = 25 °C  | I <sub>F</sub> = 10 A             | -    |      | 0.77 | V       |
|                               |                         |                         | I <sub>F</sub> = 20 A             | -    |      | 0.88 |         |
|                               |                         | T <sub>J</sub> = 125 °C | I <sub>F</sub> = 10 A             | -    | 0.59 | 0.64 |         |
|                               |                         |                         | I <sub>F</sub> = 20 A             | -    | 0.67 | 0.73 |         |

1. *Pulse test:  $t_p = 5\text{ ms}$ ,  $\delta < 2\%$*
2. *Pulse test:  $t_p = 380\ \mu\text{s}$ ,  $\delta < 2\%$*

To evaluate the conduction losses use the following equation:

$$P = 0.55 \times I_{F(AV)} + 0.009 I_{F(RMS)}^2$$

For more information, please refer to the following application notes related to the power losses :

- AN604: Calculation of conduction losses in a power rectifier
- AN4021: Calculation of reverse losses on a power diode

### 1.1 Characteristics (curves)

**Figure 1. Average forward power dissipation versus average forward current (per diode)**

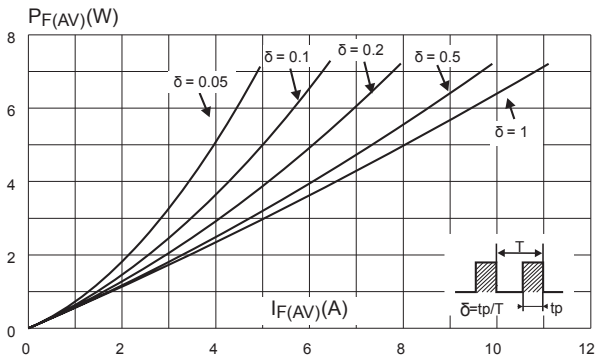

**Figure 2. Average forward current versus ambient temperature ( $\delta = 0.5$ , per diode)**

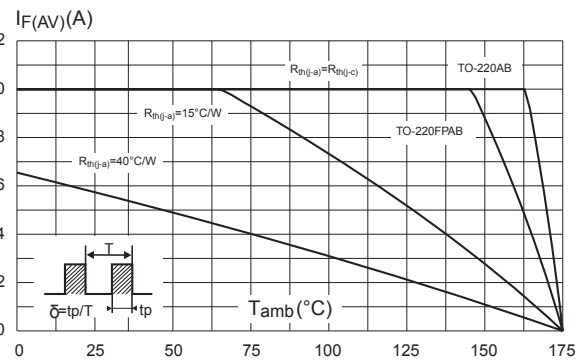

**Figure 3. Normalized avalanche power derating versus pulse duration ( $T_j = 125^\circ\text{C}$ )**

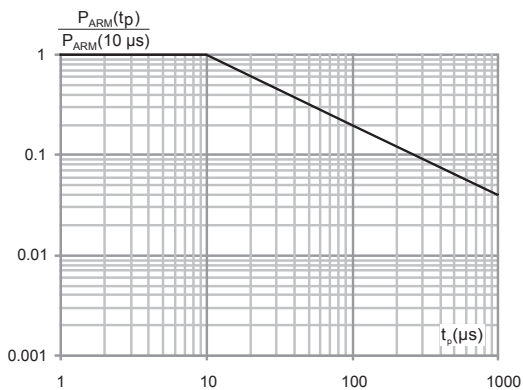

**Figure 4. Relative variation of thermal impedance junction to case versus pulse duration**

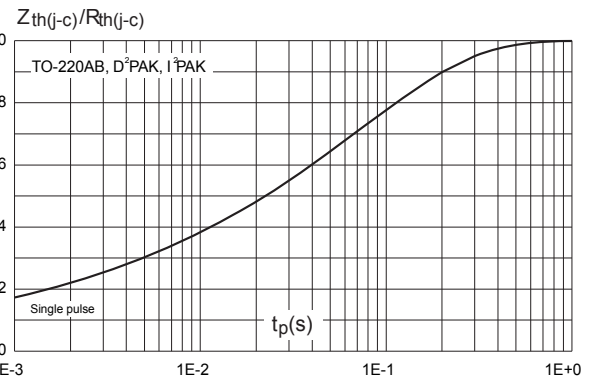

**Figure 5. Relative variation of thermal impedance junction to case versus pulse duration**

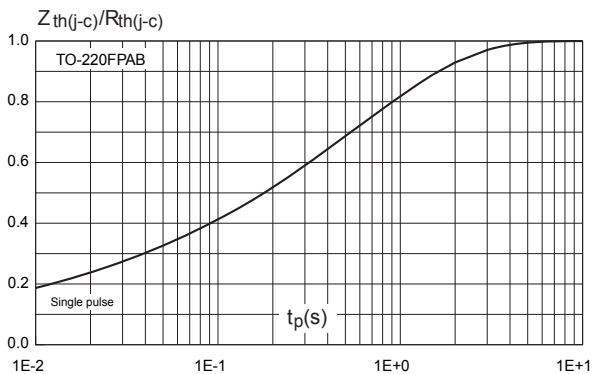

**Figure 6. Reverse leakage current versus reverse voltage applied (typical values, per diode)**

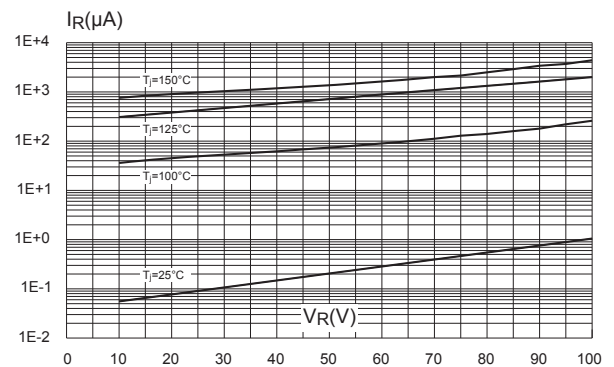

**Figure 7. Junction capacitance versus reverse voltage applied (typical values, per diode)**

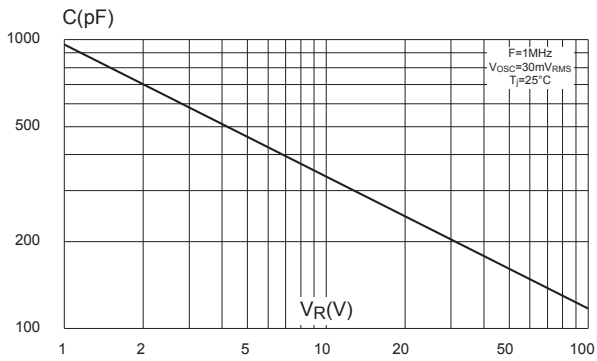

**Figure 8. Forward voltage drop versus forward current (maximum values, per diode)**

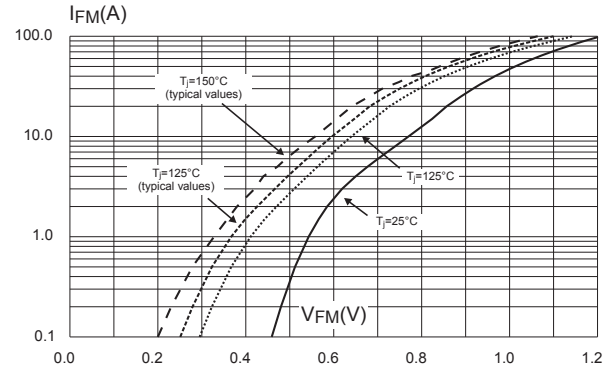

**Figure 9. Thermal resistance junction to ambient versus copper surface under tab (epoxy printed board FR4,  $e_{Cu} = 35 \mu\text{m}$ ) (D<sup>2</sup>PAK)**

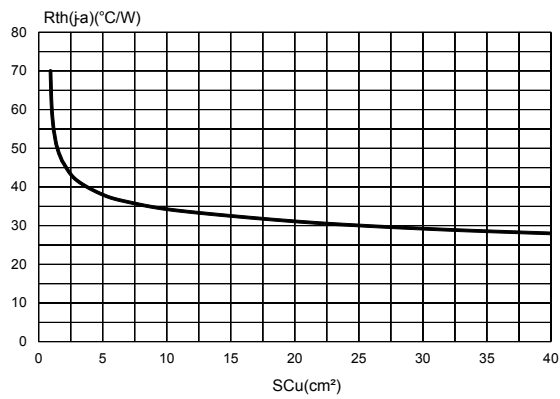

## 2 Package information

---

In order to meet environmental requirements, ST offers these devices in different grades of **ECOPACK** packages, depending on their level of environmental compliance. ECOPACK specifications, grade definitions and product status are available at: [www.st.com](http://www.st.com). ECOPACK is an ST trademark.

## 2.1 D<sup>2</sup>PAK package information

- Cooling method: by conduction (C)
- Epoxy meets UL 94,V0

Figure 10. D<sup>2</sup>PAK package outline

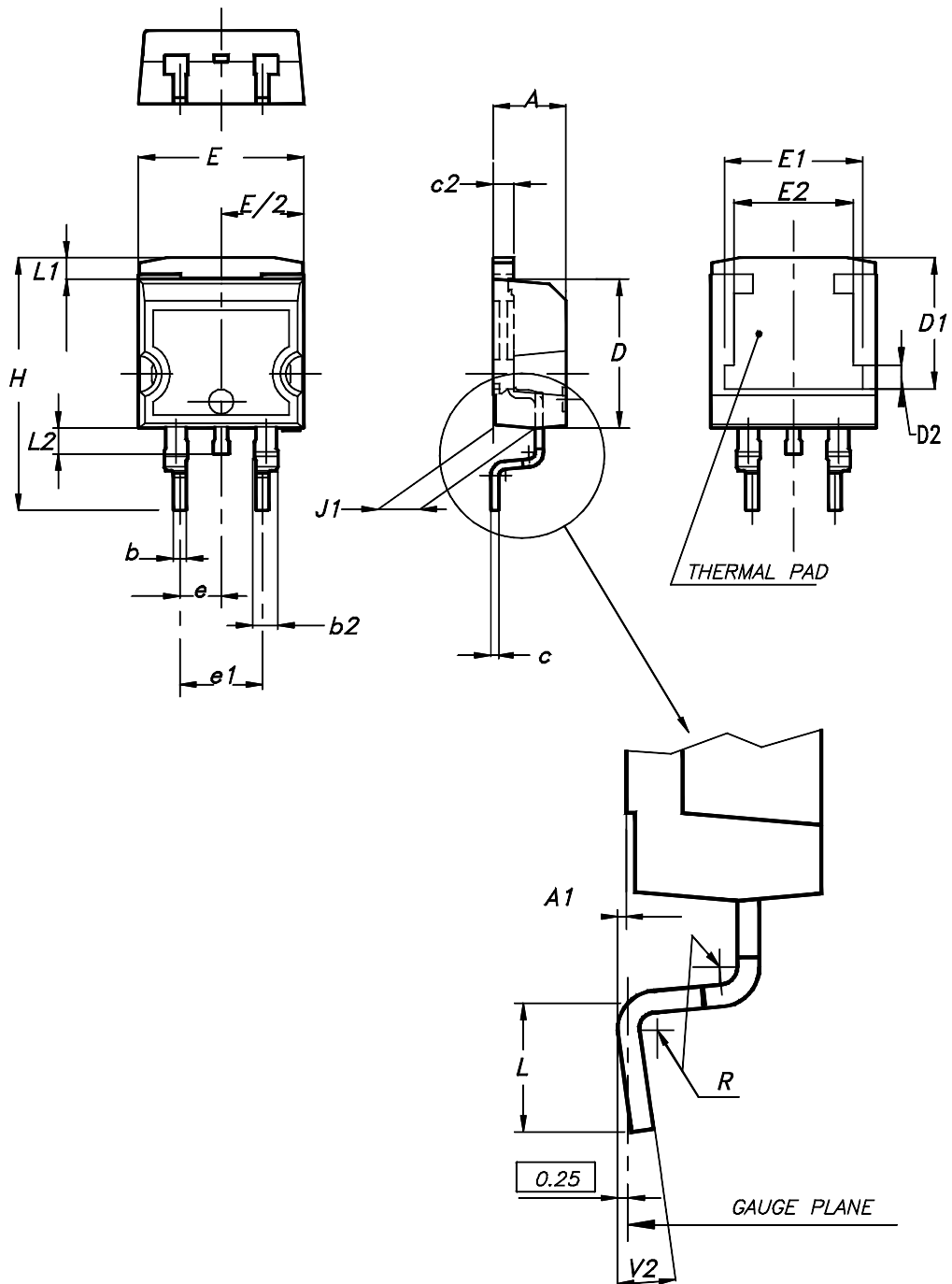

**Table 4. D<sup>2</sup>PAK package mechanical data**

| Ref. | Dimensions  |       |        |       |
|------|-------------|-------|--------|-------|
|      | Millimeters |       | Inches |       |
|      | Min.        | Max.  | Min.   | Max.  |
| A    | 4.36        | 4.60  | 0.172  | 0.181 |
| A1   | 0.00        | 0.25  | 0.000  | 0.010 |
| b    | 0.70        | 0.93  | 0.028  | 0.037 |
| b2   | 1.14        | 1.70  | 0.045  | 0.067 |
| c    | 0.38        | 0.69  | 0.015  | 0.027 |
| c2   | 1.19        | 1.36  | 0.047  | 0.053 |
| D    | 8.60        | 9.35  | 0.339  | 0.368 |
| D1   | 6.90        | 8.00  | 0.272  | 0.311 |
| D2   | 1.10        | 1.50  | 0.043  | 0.060 |
| E    | 10.00       | 10.55 | 0.394  | 0.415 |
| E1   | 8.10        | 8.90  | 0.319  | 0.346 |
| E2   | 6.85        | 7.25  | 0.266  | 0.282 |
| e    | 2.54 typ.   |       | 0.100  |       |
| e1   | 4.88        | 5.28  | 0.190  | 0.205 |
| H    | 15.00       | 15.85 | 0.591  | 0.624 |
| J1   | 2.49        | 2.90  | 0.097  | 0.112 |
| L    | 1.90        | 2.79  | 0.075  | 0.110 |
| L1   | 1.27        | 1.65  | 0.049  | 0.065 |
| L2   | 1.30        | 1.78  | 0.050  | 0.070 |
| R    | 0.4 typ.    |       | 0.015  |       |
| V2   | 0°          | 8°    | 0°     | 8°    |

Figure 11. D<sup>2</sup>PAK Recommended footprint

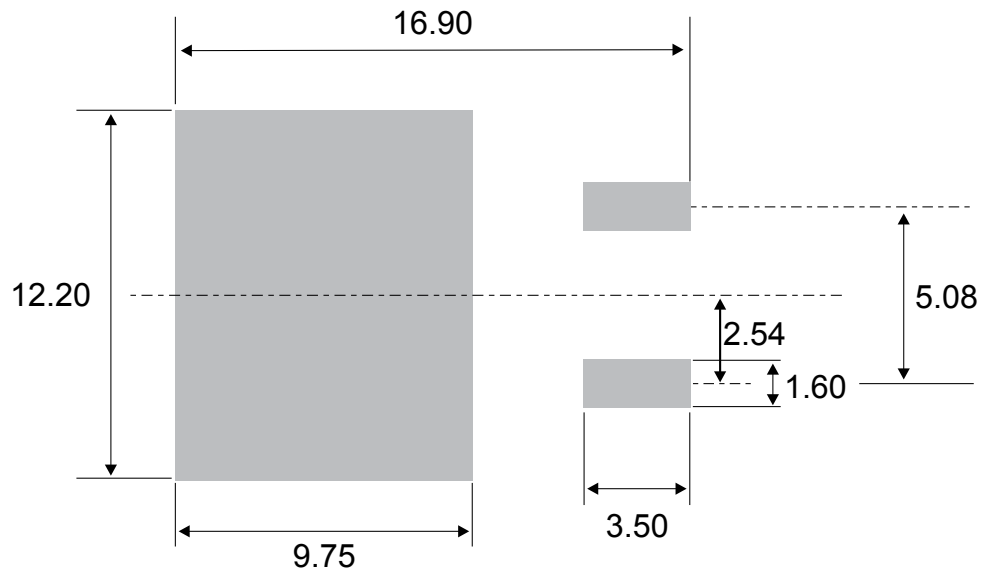

## 2.2 I<sup>2</sup>PAK package information

- Epoxy meets UL 94,V0
- Cooling method: by conduction (C)

Figure 12. I<sup>2</sup>PAK package outline

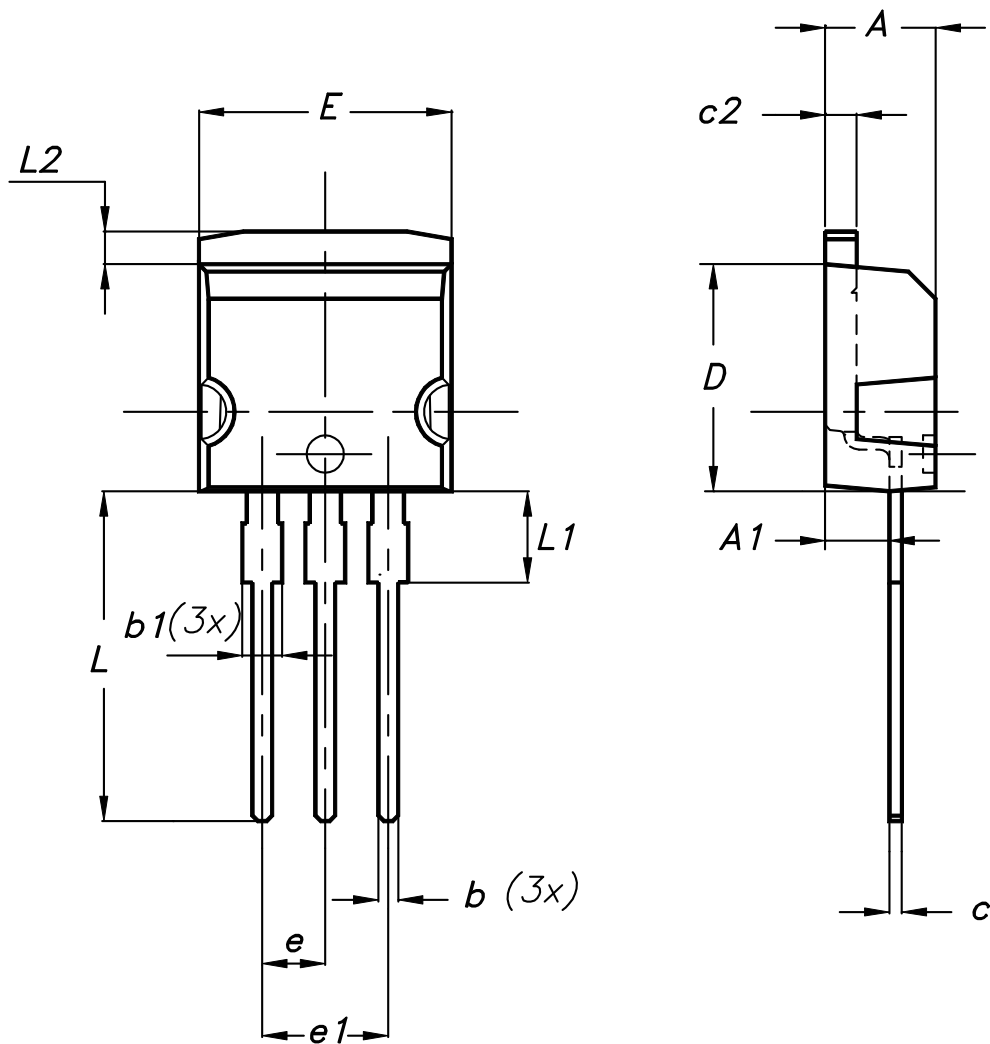

**Table 5. I<sup>2</sup>PAK package mechanical data**

| Ref. | Dimensions  |       |                             |       |
|------|-------------|-------|-----------------------------|-------|
|      | Millimeters |       | Inches (for reference only) |       |
|      | Min.        | Max.  | Min.                        | Max.  |
| A    | 4.40        | 4.60  | 0.173                       | 0.181 |
| A1   | 2.40        | 2.72  | 0.094                       | 0.107 |
| b    | 0.61        | 0.88  | 0.024                       | 0.035 |
| b1   | 1.14        | 1.70  | 0.044                       | 0.067 |
| c    | 0.49        | 0.70  | 0.019                       | 0.028 |
| c2   | 1.23        | 1.32  | 0.048                       | 0.052 |
| D    | 8.95        | 9.35  | 0.352                       | 0.368 |
| e    | 2.40        | 2.70  | 0.094                       | 0.106 |
| e1   | 4.95        | 5.15  | 0.195                       | 0.203 |
| E    | 10.00       | 10.40 | 0.394                       | 0.409 |
| L    | 13.00       | 14.00 | 0.512                       | 0.551 |
| L1   | 3.50        | 3.93  | 0.138                       | 0.155 |
| L2   | 1.27        | 1.40  | 0.050                       | 0.055 |

### 2.3 TO-220AB package information

- Cooling method: by conduction (C)
- Epoxy meets UL 94,V0
- Recommended torque value: 0.55 N·m
- Maximum torque value: 0.7 N·m

Figure 13. TO-220AB package outline

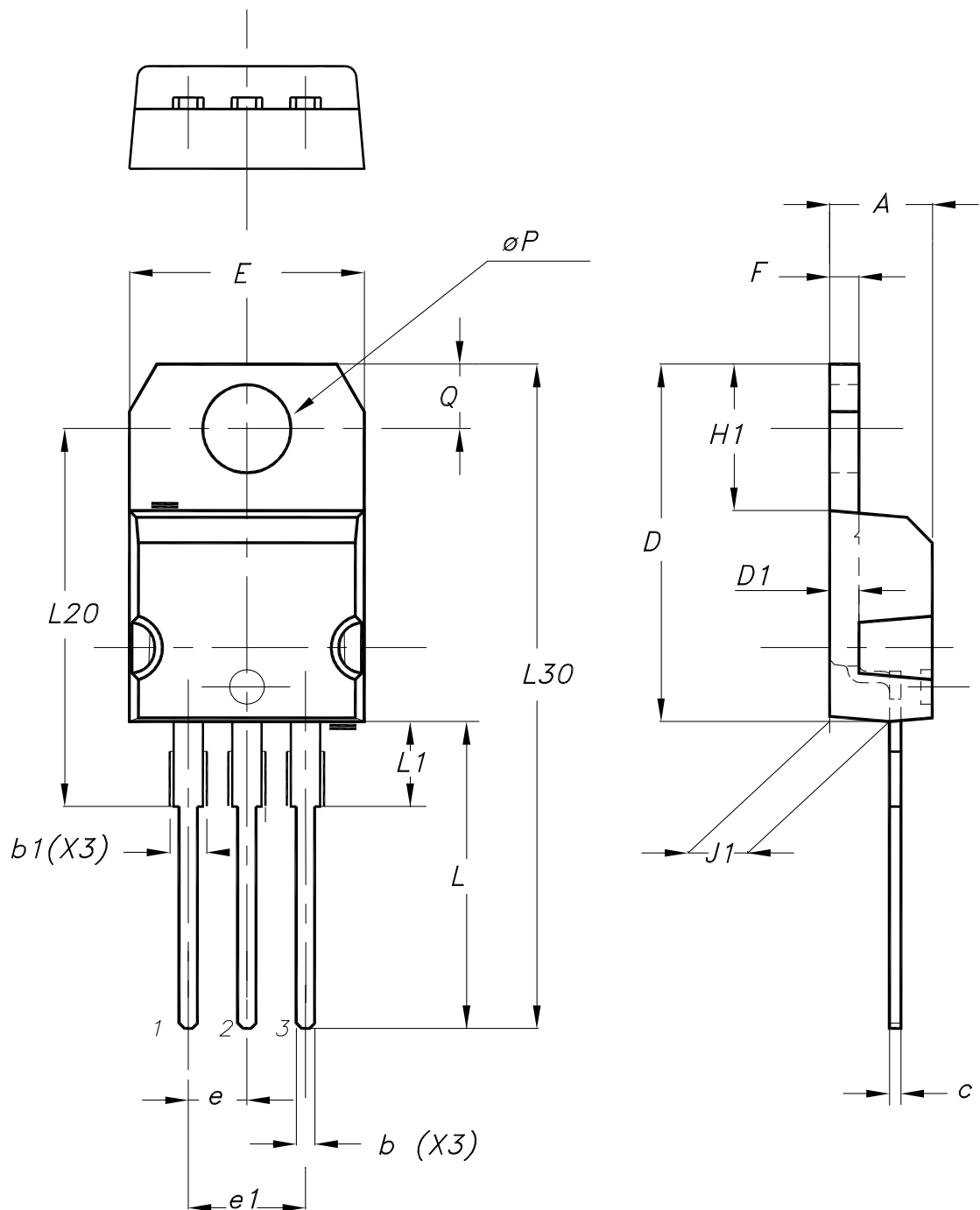

**Table 6. TO-220AB package mechanical data**

| Ref. | Dimensions  |       |            |       |
|------|-------------|-------|------------|-------|
|      | Millimeters |       | Inches     |       |
|      | Min.        | Max.  | Min.       | Max.  |
| A    | 4.40        | 4.60  | 0.173      | 0.181 |
| b    | 0.61        | 0.88  | 0.240      | 0.035 |
| b1   | 1.14        | 1.55  | 0.045      | 0.061 |
| c    | 0.48        | 0.70  | 0.019      | 0.028 |
| D    | 15.25       | 15.75 | 0.600      | 0.620 |
| D1   | 1.27 typ.   |       | 0.050 typ. |       |
| E    | 10.00       | 10.40 | 0.394      | 0.409 |
| e    | 2.40        | 2.70  | 0.094      | 0.106 |
| e1   | 4.95        | 5.15  | 0.195      | 0.203 |
| F    | 1.23        | 1.32  | 0.048      | 0.052 |
| H1   | 6.20        | 6.60  | 0.244      | 0.260 |
| J1   | 2.40        | 2.72  | 0.094      | 0.107 |
| L    | 13.00       | 14.00 | 0.512      | 0.551 |
| L1   | 3.50        | 3.93  | 0.138      | 0.155 |
| L20  | 16.40 typ.  |       | 0.646 typ. |       |
| L30  | 28.90 typ.  |       | 1.138 typ. |       |
| θP   | 3.75        | 3.85  | 0.148      | 0.152 |
| Q    | 2.65        | 2.95  | 0.104      | 0.116 |

## 2.4 TO-220FPAB package information

- Epoxy meets UL 94,V0
- Cooling method: by conduction (C)
- Recommended torque value: 0.55 N·m
- Maximum torque value: 0.70 N·m

Figure 14. TO-220FPAB package outline

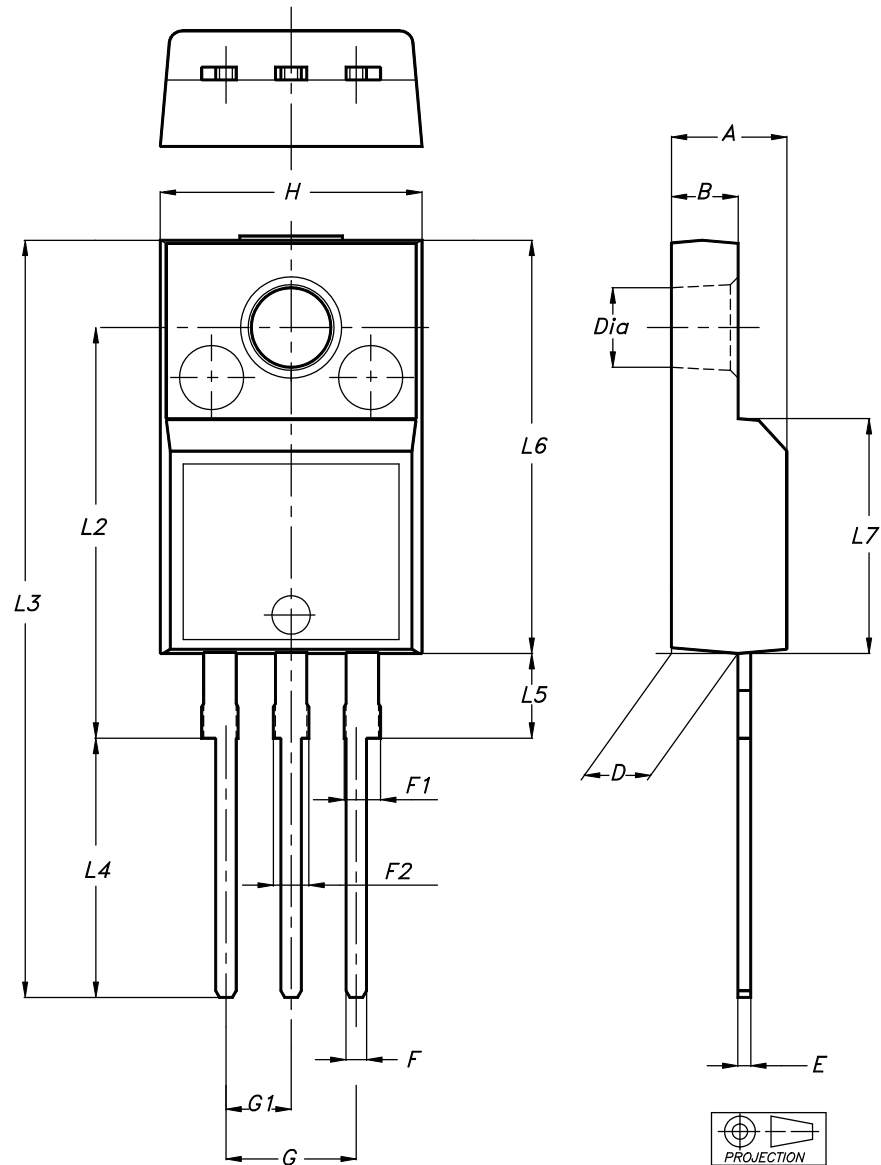

**Table 7. TO-220FPAB package mechanical data**

| Ref. | Dimensions  |       |                             |        |
|------|-------------|-------|-----------------------------|--------|
|      | Millimeters |       | Inches (for reference only) |        |
|      | Min.        | Max.  | Min.                        | Max.   |
| A    | 4.40        | 4.60  | 0.1739                      | 0.1818 |
| B    | 2.50        | 2.70  | 0.0988                      | 0.1067 |
| D    | 2.50        | 2.75  | 0.0988                      | 0.1087 |
| E    | 0.45        | 0.70  | 0.0178                      | 0.0277 |
| F    | 0.75        | 1.00  | 0.0296                      | 0.0395 |
| F1   | 1.15        | 1.70  | 0.0455                      | 0.0672 |
| F2   | 1.15        | 1.70  | 0.0455                      | 0.0672 |
| G    | 4.95        | 5.20  | 0.1957                      | 0.2055 |
| G1   | 2.40        | 2.70  | 0.0949                      | 0.1067 |
| H    | 10.00       | 10.40 | 0.3953                      | 0.4111 |
| L2   | 16.00 typ.  |       | 0.6324 typ.                 |        |
| L3   | 28.60       | 30.60 | 1.1304                      | 1.2095 |
| L4   | 9.80        | 10.60 | 0.3874                      | 0.4190 |
| L5   | 2.90        | 3.60  | 0.1146                      | 0.1423 |
| L6   | 15.90       | 16.40 | 0.6285                      | 0.6482 |
| L7   | 9.00        | 9.30  | 0.3557                      | 0.3676 |
| Dia  | 3.00        | 3.20  | 0.1186                      | 0.1265 |

### 3 Ordering information

**Table 8. Ordering information**

| Order code      | Marking       | Package            | Weight | Base qty | Delivery mode |
|-----------------|---------------|--------------------|--------|----------|---------------|
| STPS20H100CT    | STPS20H100CT  | TO-220AB           | 1.95 g | 50       | Tube          |
| STPS20H100CFP   | STPS20H100CFP | TO-220FPAB         | 1.90 g | 50       | Tube          |
| STPS20H100CR    | STPS20H100CR  | I <sup>2</sup> PAK | 1.50 g | 50       | Tube          |
| STPS20H100CG    | STPS20H100CG  | D <sup>2</sup> PAK | 1.48 g | 50       | Tube          |
| STPS20H100CG-TR | STPS20H100CG  | D <sup>2</sup> PAK | 1.48 g | 1000     | Tape and reel |

## Revision history

**Table 9. Document revision history**

| Date        | Revision | Changes                                                                                                                                                                                                   |
|-------------|----------|-----------------------------------------------------------------------------------------------------------------------------------------------------------------------------------------------------------|
| Jul-2003    | 4G       | Previous release                                                                                                                                                                                          |
| 21-Mar-2007 | 5        | Removed ISOWATT package                                                                                                                                                                                   |
| 10-Sep-2007 | 6        | Reformatted cover page to current standards - no technical changes. Updated dimensions A1, b, b1, c, c2, L, and L1 in Table 8.                                                                            |
| 22-Sep-2011 | 7        | Updated Table 8.                                                                                                                                                                                          |
| 21-May-2015 | 8        | Updated features, and packages silhouette in cover page. Updated Section 1: "Characteristics" and Section 1.1: "Characteristics (curves)". Updated Section 2.2: "D <sup>2</sup> PAK package information". |
| 16-Apr-2018 | 9        | Updated I <sup>2</sup> PAK package mechanical data.                                                                                                                                                       |
| 20-Jan-2020 | 10       | Updated <a href="#">Section 1 Characteristics</a> and <a href="#">Table 8. Ordering information</a> . Added <a href="#">Section Applications</a> .                                                        |

**IMPORTANT NOTICE – PLEASE READ CAREFULLY**

STMicroelectronics NV and its subsidiaries (“ST”) reserve the right to make changes, corrections, enhancements, modifications, and improvements to ST products and/or to this document at any time without notice. Purchasers should obtain the latest relevant information on ST products before placing orders. ST products are sold pursuant to ST’s terms and conditions of sale in place at the time of order acknowledgement.

Purchasers are solely responsible for the choice, selection, and use of ST products and ST assumes no liability for application assistance or the design of Purchasers’ products.

No license, express or implied, to any intellectual property right is granted by ST herein.

Resale of ST products with provisions different from the information set forth herein shall void any warranty granted by ST for such product.

ST and the ST logo are trademarks of ST. For additional information about ST trademarks, please refer to [www.st.com/trademarks](http://www.st.com/trademarks). All other product or service names are the property of their respective owners.

Information in this document supersedes and replaces information previously supplied in any prior versions of this document.

© 2020 STMicroelectronics – All rights reserved