

Description

The LM2901Q/LM2901AQ/LM2903Q/LM2903AQ series comparators consist of four and two independent precision voltage comparators with very low input offset voltage specification. They are designed to operate from a single power supply over a wide range of voltages; however operation from split power supplies is also possible. They offer low power supply current independent of the magnitude of the power supply voltage.

The LM2901Q/LM2901AQ/LM2903Q/LM2903AQ series comparators are designed to directly interface with TTL and CMOS.

The LM2903Q/LM2903AQ dual devices are available in SO-8, MSOP-8 and TSSOP-8 packages; and the LM2901Q/LM2901AQ quad devices are available in SO-14 and TSSOP-14 packages – all are in industry-standard pinouts.

All devices use “green” mold compound and have been qualified to AEC-Q100 Grade 1 and are automotive compliant, supporting PPAPs.

Features

- Wide Power Supply Range:
 - Single Supply: 2V to 36V
 - Dual Supplies: $\pm 1.0V$ to $\pm 18V$
- Very Low Supply Current Drain – Independent of Supply Voltage
 - LM2903Q: 0.6mA
 - LM2901Q: 0.9mA
- Low Input Bias Current: 25nA
- Low Input Offset Current: $\pm 5nA$
- Typical Offset Voltage:
 - Non-A Device: 2mV
 - A Device: 1mV
- Common-Mode Input Voltage Range Includes Ground
- Differential Input Voltage Range Equal to the Power Supply Voltage
- Low Output Saturation Voltage:
 - LM2903Q: 200mV at 4mA
 - LM2901Q: 100mV at 4mA
- Output Voltage Compatible with TTL, MOS and CMOS
- Qualified to AEC-Q100 Grade 1
- **Totally Lead-Free & Fully RoHS Compliant (Notes 1 & 2)**
- **Halogen and Antimony Free. “Green” Device (Note 3)**
- **The LM2901Q/LM2901AQ/LM2903Q/LM2903AQ are suitable for automotive applications requiring specific change control; these parts are AEC-Q100 qualified, PPAP capable, and manufactured in IATF16949 certified facilities.**

<https://www.diodes.com/quality/product-definitions/>

Notes: 1. No purposely added lead. Fully EU Directive 2002/95/EC (RoHS), 2011/65/EU (RoHS 2) & 2015/863/EU (RoHS 3) compliant.
 2. See <https://www.diodes.com/quality/lead-free/> for more information about Diodes Incorporated's definitions of Halogen- and Antimony-free, "Green" and Lead-free.
 3. Halogen- and Antimony-free "Green" products are defined as those which contain <900ppm bromine, <900ppm chlorine (<1500ppm total Br + Cl) and <1000ppm antimony compounds.

Pin Assignments

LM2903Q/LM2903AQ

(Top View)

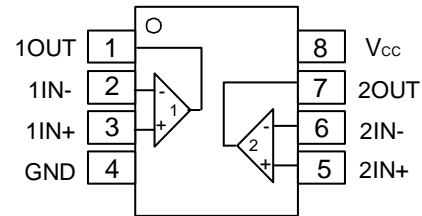

SO-8/TSSOP-8/MSOP-8

LM2901Q/LM2901AQ

(Top View)

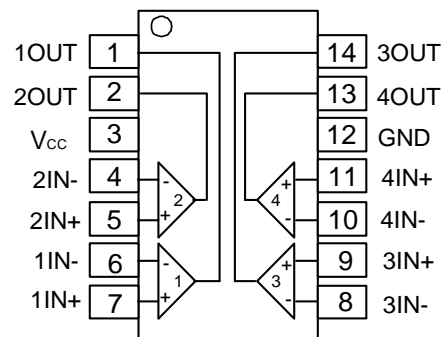

SO-14/TSSOP-14

Schematic Diagram

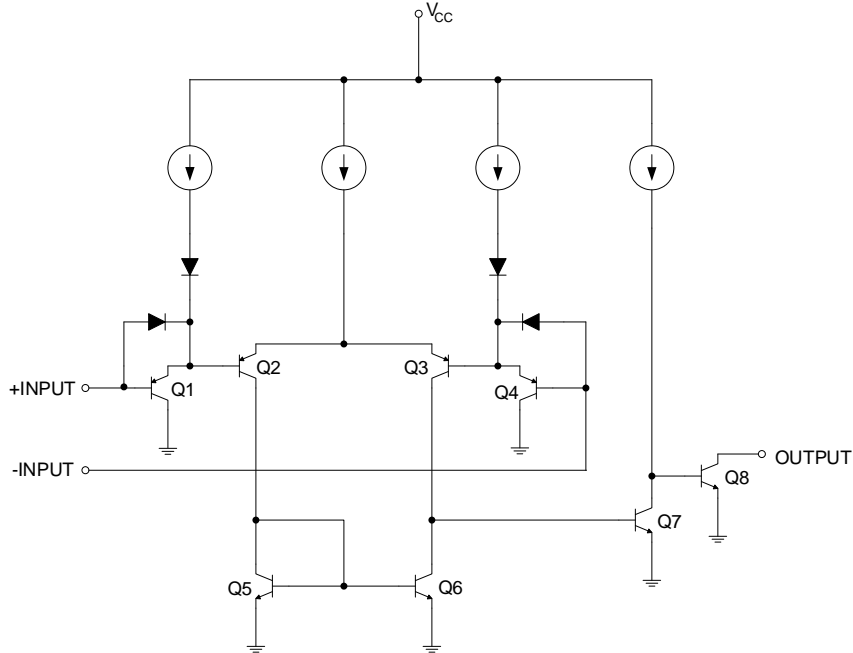

**Functional Block Diagram of LM2901Q/LM2901AQ/LM2903Q/LM2903AQ
(Each Comparator)**

Pin Descriptions

LM2901Q/LM2901AQ		
Pin Name	Pin Number	Function
1OUT	1	Channel 1 Output
2OUT	2	Channel 2 Output
V _{CC}	3	Chip Supply Voltage
2IN-	4	Channel 2 Inverting Input
2IN+	5	Channel 2 Non-Inverting Input
1IN-	6	Channel 1 Inverting Input
1IN+	7	Channel 1 Non-Inverting Input
3IN-	8	Channel 3 Inverting Input
3IN+	9	Channel 3 Non-Inverting Input
4IN-	10	Channel 4 Inverting Input
4IN+	11	Channel 4 Non-Inverting Input
GND	12	Ground
4OUT	13	Channel 4 Output
3OUT	14	Channel 3 Output
LM2903Q/LM2903AQ		
1OUT	1	Channel 1 Output
1IN-	2	Channel 1 Inverting Input
1IN+	3	Channel 1 Non-inverting Input
GND	4	Ground
2IN+	5	Channel 2 Non-Inverting Input
2IN-	6	Channel 2 Inverting Input
2OUT	7	Channel 2 Output
V _{CC}	8	Chip Supply Voltage

Absolute Maximum Ratings (Note 4) (@T_A = +25°C, unless otherwise specified.)

Symbol	Parameter	Rating	Unit	
V _{CC}	Supply Voltage	36	V	
V _{ID}	Differential Input Voltage	36	V	
V _{IN}	Input Voltage	-0.3 to +36	V	
I _{IN}	Input Current (V _{IN} < -0.3V)	50	mA	
V _O	Output Voltage	36	V	
I _O	Output Current	20	mA	
—	Duration of Output Short Circuit to Ground (Note 5)	Unlimited	—	
θ _{JA}	Package Thermal Impedance (Note 6)	SO-8	150	°C/W
		TSSOP-8	175	
		MSOP-8	200	
		SO-14	89	
		TSSOP-14	100	
T _A	Operating Temperature Range	-40 to +125	°C	
T _J	Operating Junction Temperature	+150	°C	
T _{ST}	Storage Temperature Range	-65 to +150	°C	
T _{LEAD}	Lead Temperature (Soldering, 10 seconds)	+260	°C	

- Notes:
- Stresses greater than those listed under *Absolute Maximum Ratings* can cause permanent damage to the device. These are stress ratings only, and functional operation of the device at these or any other conditions beyond those indicated under *Recommended Operating Conditions* is not implied. Exposure to *Absolute Maximum Ratings* for extended periods can affect device reliability.
 - Short circuits from outputs to V_{CC} can cause excessive heating and eventual destruction.
 - Maximum power dissipation is a function of T_{J(MAX)}, θ_{JA}, and T_A. The maximum allowable power dissipation at any allowable ambient temperature is $P_D = (T_{J(MAX)} - T_A) / \theta_{JA}$. Operating at the absolute maximum T_J of +150°C can affect reliability.

ESD Ratings

Parameter	Rating	Unit	
Human Body Mode ESD Protection (Note 7)	SO-14	500	V
	TSSOP-14	500	
	SO-8	500	
	TSSOP-8	500	
	MSOP-8	< 500	
Charge Device Mode ESD Protection	SO-14	1,000	
	TSSOP-14		
	SO-8		
	TSSOP-8		
	MSOP-8		

Note: 7. Human body model, 1.5kΩ in series with 100pF.

Recommended Operating Conditions (Over Operating Free-Air Temperature Range, unless otherwise noted.)

Parameter	Min	Max	Units
Supply Voltage	Single Supply	2	V
	Dual Supply	±1	
Ambient Temperature Range	-40	+125	°C
Junction Temperature Range	-40	+125	

Electrical Characteristics (Notes 8 & 9) (@ $V_{CC} = 5.0V$, $GND = 0V$, $T_A = +25^{\circ}C$, unless otherwise specified.)

LM2901Q/LM2901AQ

Parameter		Conditions		T_A	Min	Typ	Max	Unit
V_{IO}	Input Offset Voltage	$V_{IC} = V_{CMR} \text{ Min}$ $V_O = 1.4V$ $V_{CC} = 5V \text{ to } 30V$ (Note 10)	Non-A Device	$T_A = +25^{\circ}C$	—	2	7	mV
				Full Range	—	—	15	
			A-Suffix Device	$T_A = +25^{\circ}C$	—	1	2	
				Full Range	—	—	4	
I_B	Input Bias Current	I_{IN+} or I_{IN-} with OUT in Linear Range $V_{CM} = 0V$ (Note 11)	$T_A = +25^{\circ}C$	—	25	250	nA	
			Full Range	—	—	500		
I_{IO}	Input Offset Current	$I_{IN+} - I_{IN-}$, $V_{CM} = 0V$	$T_A = +25^{\circ}C$	—	5	50	nA	
			Full Range	—	—	200		
V_{CMR}	Input Common-Mode Voltage Range	$V_{CC} = 30V$ (Note 12)	$T_A = +25^{\circ}C$	0 to $V_{CC} - 1.5$	—	—	V	
			Full Range	0 to $V_{CC} - 2$	—	—		
I_{CC}	Supply Current (Four Comparators)	$R_L = \infty$ on Quad Channels	$V_{CC} = 30V$	$T_A = +25^{\circ}C$	—	1.2	2.5	mA
				Full range	—	—	3.5	
			$V_{CC} = 5V$	$T_A = +25^{\circ}C$	—	0.9	2	
				Full Range	—	—	3.0	
A_V	Voltage Gain	$V_{CC} = 15V$, $V_{OUT} = 1V \text{ to } 11V$ $R_L \geq 15k\Omega$	$T_A = +25^{\circ}C$	50	200	—	V/mV	
—	Large Signal Response Time	$V_{IN} = \text{TTL Logic Swing}$, $V_{REF} = 1.4V$ $V_{RL} = 5V$, $R_L = 5.1k\Omega$	$T_A = +25^{\circ}C$	—	300	—	ns	
—	Response Time	$V_{RL} = 5V$, $R_L = 5.1k\Omega$ (Note 13)	$T_A = +25^{\circ}C$	—	1.3	—	μs	
$I_{O(SINK)}$	Output Sink Current	$V_{IN-} = 1V$, $V_{IN+} = 0$, $V_O \leq 1.5V$	$T_A = +25^{\circ}C$	6	16	—	mA	
V_{SAT}	Saturation Voltage	$V_{IN-} = 1V$, $V_{IN+} = 0$, $I_{SINK} \leq 4mA$	$T_A = +25^{\circ}C$	—	100	400	mV	
			Full Range	—	—	700		
$I_{O(LEAK)}$	Output Leakage Current	$V_{IN-} = 0V$, $V_{IN+} = 1$, $V_O = 5V$	$T_A = +25^{\circ}C$	—	0.1	—	nA	
		$V_{IN-} = 0V$, $V_{IN+} = 1$, $V_O = 30V$	Full Range	—	—	1	μA	
V_{ID}	Differential Input Voltage	All $V_{IN} \geq 0V$ (or V_- if used) (Note 14)	Full Range	—	—	36	V	

- Notes:
- Typical values represent the most likely parametric norm as determined at the time of characterization. Actual typical values may vary over time and will also depend on the application and configuration. The typical values are not tested and are not guaranteed on shipped production material.
 - All limits are guaranteed by testing or statistical analysis. Limits over the full temperature ($-40 \leq T_A \leq +125^{\circ}C$) are guaranteed by design, but not tested in production.
 - $V_O \cong 1.4V$, $R_S = 0\Omega$ with V_{CC} from 5V to 30V.
 - The direction of the input current is out of the IC due to the PNP input stage. This current is essentially constant, independent of the state of the output so no loading change exists on the input lines.
 - The input common-mode voltage of either input signal voltage should not be allowed to go negative by more than 0.3V (@ $+25^{\circ}C$). The upper end of the common-mode voltage range is $V_{CC} - 1.5V$ (@ $+25^{\circ}C$), but either or both inputs can go to +36V without damage, independent of the magnitude of V_{CC} .
 - The response time specified is for a 100mV step input with 5mV overdrive. For larger overdrive signals 300ns can be obtained, see *Typical Performance Characteristics*.
 - Positive excursions of input voltage may exceed the power supply level. As long as other voltages remain within the common mode range, the comparator will provide a proper output stage. The low voltage state must not be less than -0.3V (or 0.3V below the magnitude of the negative power supply, if used).

Electrical Characteristics (continued) (Notes 8 & 9) (@ $V_{CC} = 5.0V$, $GND = 0V$, $T_A = +25^\circ C$, unless otherwise specified.)

LM2903Q/LM2903AQ

Parameter		Conditions		T_A	Min	Typ	Max	Unit
V_{IO}	Input Offset Voltage	$V_{IC} = V_{CMR}$ Min $V_O = 1.4V$ $V_{CC} = 5V$ to $30V$ (Note 10)	Non-A Device	$T_A = +25^\circ C$	—	2	7	mV
				Full Range	—	—	15	
			A-Suffix Device	$T_A = +25^\circ C$	—	1	2	
				Full Range	—	—	4	
I_B	Input Bias Current	I_{IN+} or I_{IN-} with OUT in Linear Range $V_{CM} = 0V$ (Note 11)	$T_A = +25^\circ C$	—	25	250	nA	
			Full Range	—	—	500		
I_{IO}	Input Offset Current	$I_{IN+} - I_{IN-}$, $V_{CM} = 0V$	$T_A = +25^\circ C$	—	5	50	nA	
			Full Range	—	—	200		
V_{CMR}	Input Common-Mode Voltage Range	$V_{CC} = 30V$ (Note 12)	$T_A = +25^\circ C$	0 to $V_{CC}-1.5$	—	—	V	
			Full Range	0 to $V_{CC}-2$	—	—		
I_{CC}	Supply Current	$R_L = \infty$ on Both Channels	$V_{CC} = 30V$	$T_A = +25^\circ C$	—	0.7	1.7	mA
				Full Range	—	—	3.0	
			$V_{CC} = 5V$	$T_A = +25^\circ C$	—	0.6	1	
				Full Range	—	—	2.0	
A_V	Voltage Gain	$V_{CC} = 15V$, $V_{OUT} = 1V$ to $11V$ $R_L \geq 15k\Omega$,	$T_A = +25^\circ C$	50	200	—	V/mV	
—	Large Signal Response Time	$V_{IN} = TTL$ Logic Swing, $V_{REF} = 1.4V$ $V_{RL} = 5V$, $R_L = 5.1k\Omega$	$T_A = +25^\circ C$	—	300	—	ns	
—	Response Time	$V_{RL} = 5V$, $R_L = 5.1k\Omega$ (Note 13)	$T_A = +25^\circ C$	—	1.3	—	μs	
$I_{O(SINK)}$	Output Sink Current	$V_{IN-} = 1V$, $V_{IN+} = 0$, $V_O \leq 1.5V$	$T_A = +25^\circ C$	6	16	—	mA	
V_{SAT}	Saturation Voltage	$V_{IN-} = 1V$, $V_{IN+} = 0$, $I_{SINK} \leq 4mA$	$T_A = +25^\circ C$	—	200	400	mV	
			Full Range	—	—	700		
$I_{O(LEAK)}$	Output Leakage Current	$V_{IN-} = 0V$, $V_{IN+} = 1$, $V_O = 5V$	$T_A = +25^\circ C$	—	0.1	—	nA	
		$V_{IN-} = 0V$, $V_{IN+} = 1$, $V_O = 30V$	Full Range	—	—	1	μA	
V_{ID}	Differential Input Voltage	All $V_{IN} \geq 0V$ (or V- if used) (Note 14)	Full Range	—	—	36	V	

- Notes:
8. Typical values represent the most likely parametric norm as determined at the time of characterization. Actual typical values may vary over time and will also depend on the application and configuration. The typical values are not tested and are not guaranteed on shipped production material.
 9. All limits are guaranteed by testing or statistical analysis. Limits over the full temperature ($-40 \leq T_A \leq +125^\circ C$) are guaranteed by design, but not tested in production.
 10. $V_O \cong 1.4V$, $R_S = 0\Omega$ with V_{CC} from $5V$ to $30V$.
 11. The direction of the input current is out of the IC due to the PNP input stage. This current is essentially constant, independent of the state of the output so no loading change exists on the input lines.
 12. The input common-mode voltage of either input signal voltage should not be allowed to go negative by more than $0.3V$ (@ $+25^\circ C$). The upper end of the common-mode voltage range is $V_{CC} - 1.5V$ (@ $+25^\circ C$), but either or both inputs can go to $+36V$ without damage, independent of the magnitude of V_{CC} .
 13. The response time specified is for a $100mV$ step input with $5mV$ overdrive. For larger overdrive signals $300ns$ can be obtained, see *Typical Performance Characteristics*.
 14. Positive excursions of input voltage may exceed the power supply level. As long as other voltages remain within the common mode range, the comparator will provide a proper output stage. The low voltage state must not be less than $-0.3V$ (or $0.3V$ below the magnitude of the negative power supply, if used).

Performance Characteristics

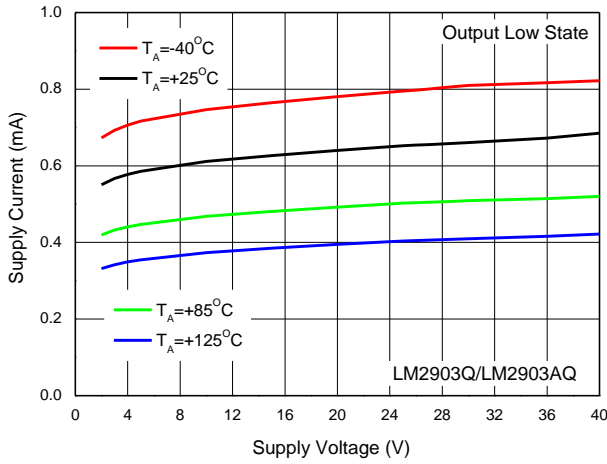

Supply Current vs. Supply Voltage

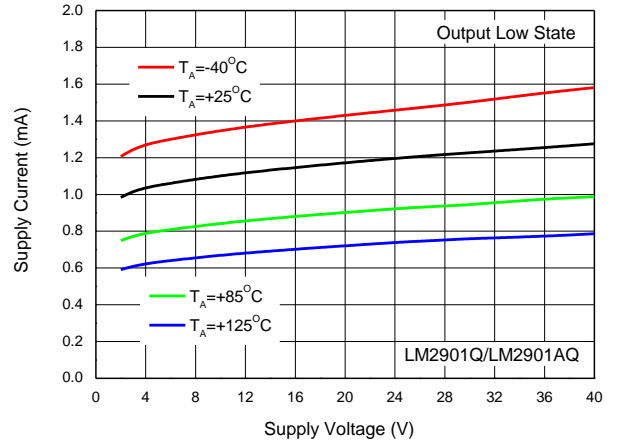

Supply Current vs. Supply Voltage

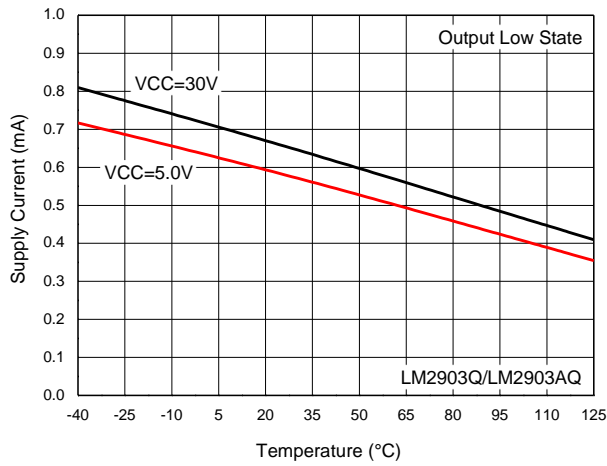

Supply Current vs. Temperature

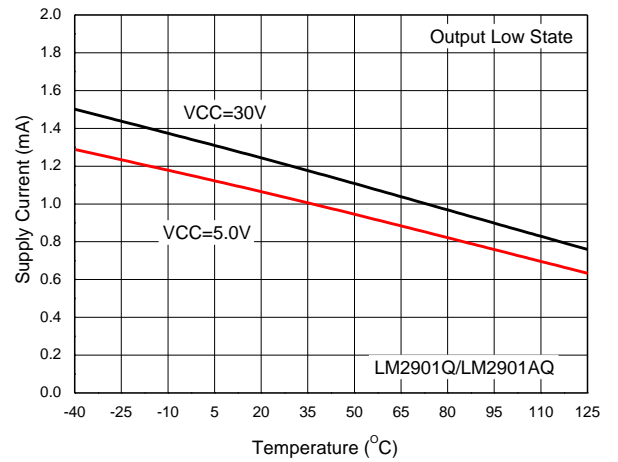

Supply Current vs. Temperature

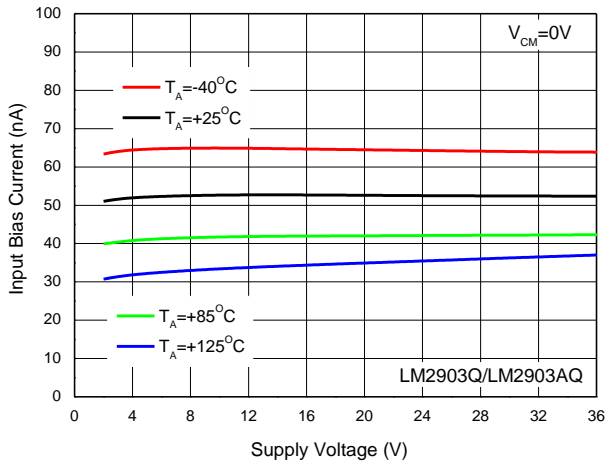

Input Bias Current vs. Supply Voltage

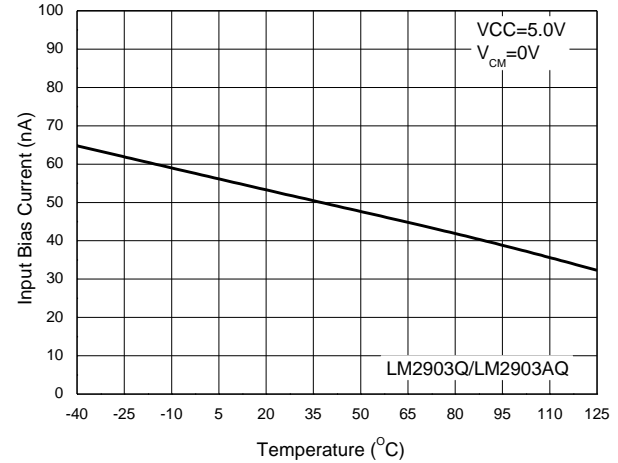

Input Bias Current vs. Temperature

Performance Characteristics (continued)

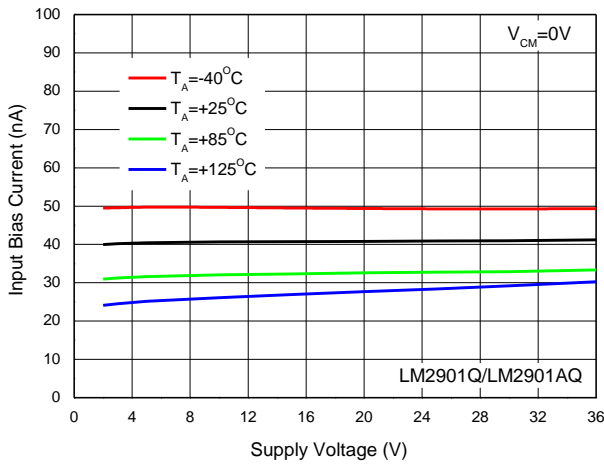

Input Bias Current vs. Supply Voltage

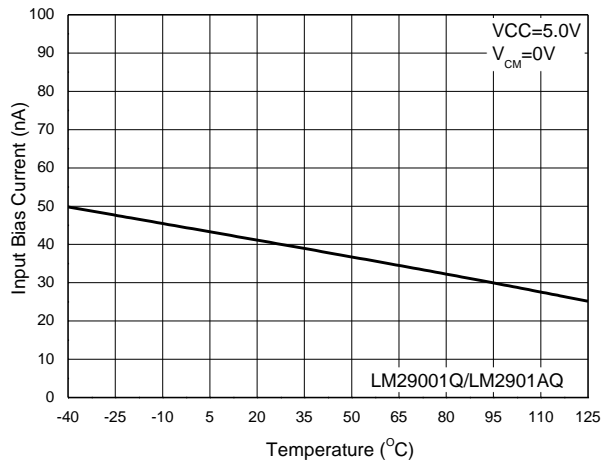

Input Bias Current vs. Temperature

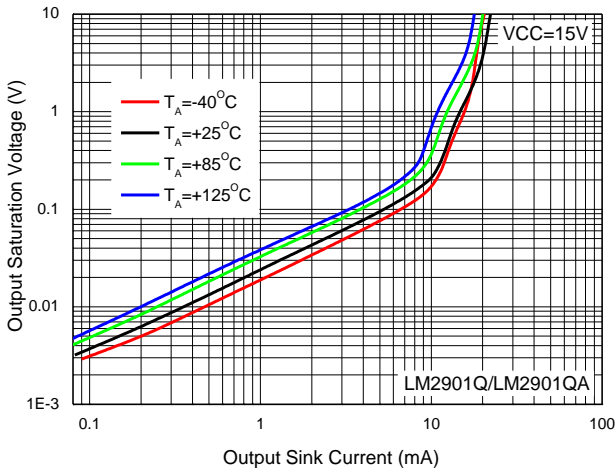

Output Saturation Voltage vs. Sink Current

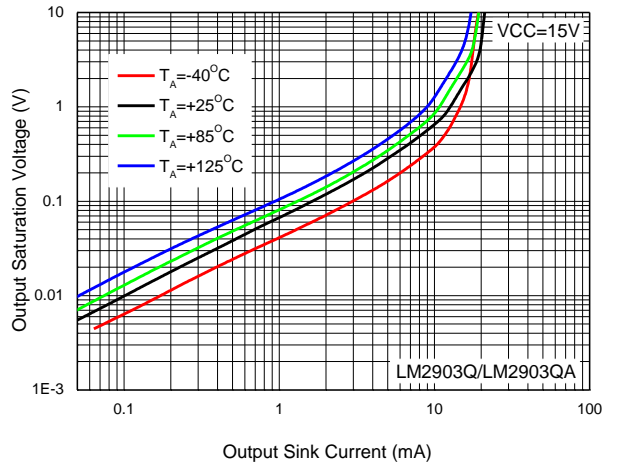

Output Saturation Voltage vs. Sink Current

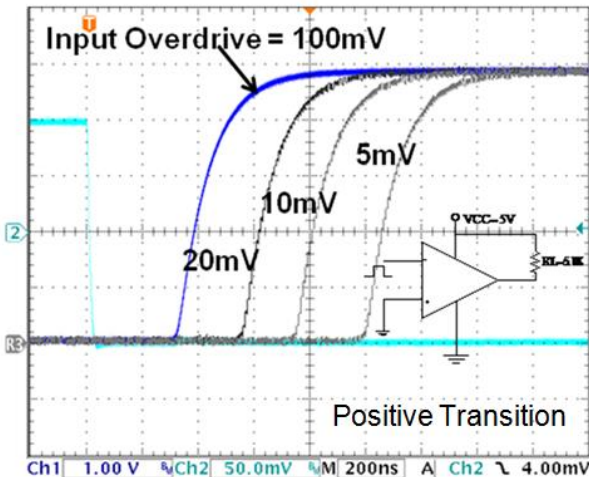

Response Time for Various Input Overdrive

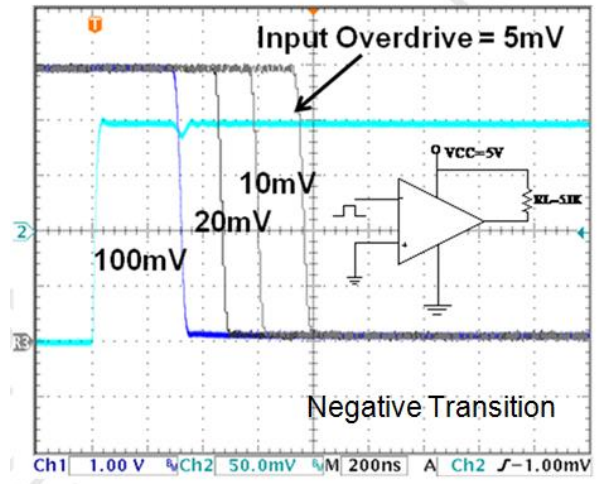

Response Time for Various Input Overdrive

Performance Characteristics (continued)

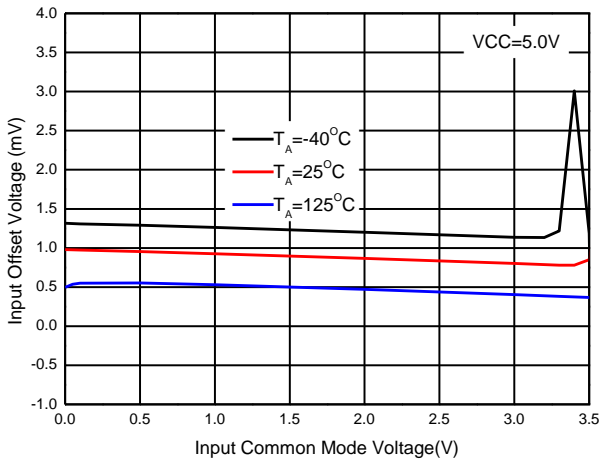

Input Offset Voltage vs. Input Common-Mode Voltage

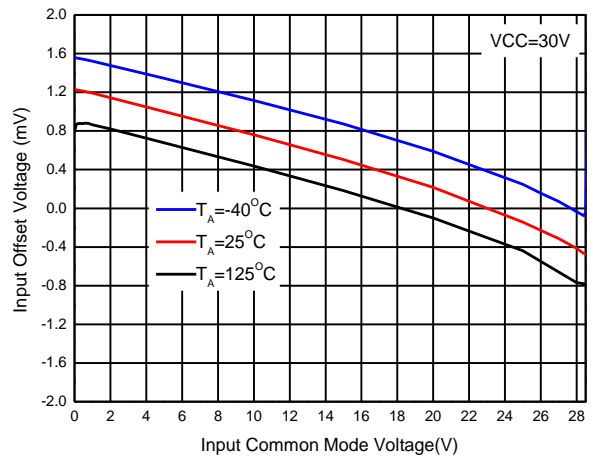

Input Offset Voltage vs. Input Common-Mode Voltage

Application Information

General Information

The LM2901Q/LM2901AQ/LM2903Q/LM2903AQ series comparators are high-gain, wide-bandwidth devices, and like most comparators, can easily oscillate if the output lead is inadvertently allowed to capacitively couple to the inputs via stray capacitance. This shows up only during the output voltage transition intervals as the comparator changes states. Standard PC board layout is helpful as it reduces stray input-output coupling. Reducing the input resistors to < 10k Ω reduces the feedback signal levels and finally, adding even a small amount (1.0mV to 10mV) of positive feedback (hysteresis) causes such a rapid transition that oscillations due to stray feedback are not possible. Simply socketing the IC and attaching resistors to the pins will cause input-output oscillations during the small transition intervals unless hysteresis is used. If the input signal is a pulse waveform, with relatively fast rise and fall times, hysteresis is not required. All input pins of any unused comparators should be tied to the negative supply.

The bias network of the LM2901Q/LM2901AQ/LM2903Q/LM2903AQ series comparators establishes a quiescent current independent of the magnitude of the power supply voltage over the range of from 2.0V_{DC} to 30V_{DC}.

The differential input voltage may be larger than V_{CC} without damaging the device. Protection should be provided to prevent the input voltages from becoming negative more than -0.3V_{DC} (@ +25°C). An input clamp diode can be used as shown in the applications section.

The output of the LM2901Q/LM2901AQ/LM2903Q/LM2903AQ series comparators is the uncommitted collector of a grounded-emitter NPN output transistor. Many collectors can be tied together to provide an output ORing function. An output pullup resistor can be connected to any available power supply voltage within the permitted supply voltage range and there is no restriction on this voltage due to the magnitude of the voltage applied to the V_{CC} terminal of LM2901Q/LM2901AQ/LM2903Q/LM2903AQ series comparator package. The output can also be used as a simple SPST switch to ground (when a pullup resistor is not used).

The amount of current the output device can sink is limited by the drive available (which is independent of V_{CC}) and the β of this device. When the maximum current limit is reached (approximately 16mA), the output transistor will come out of saturation and the output voltage will rise very rapidly. The output saturation voltage is limited by the approximately 60 Ω R_{SAT} of the output transistor. The low offset voltage of the output transistor (1.0mV) allows the output to clamp essentially to ground level for small load currents.

Typical Application Circuit ($V_{CC} = 5.0V_{DC}$)

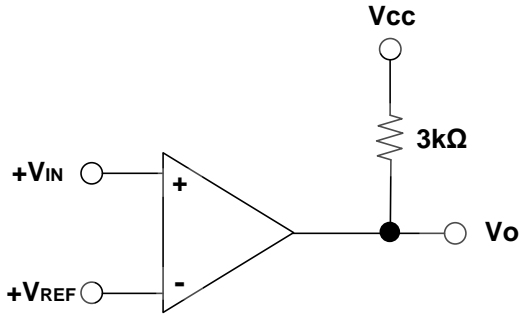

Basic Comparator

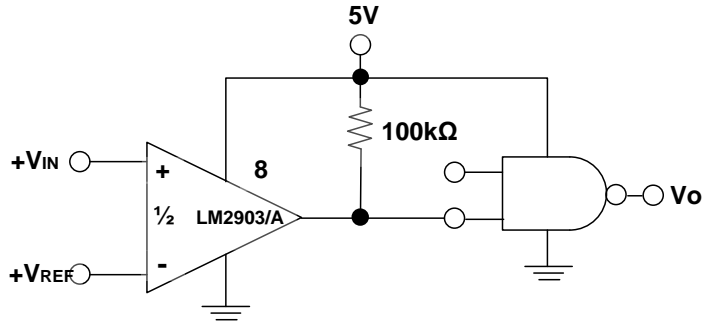

Driving CMOS

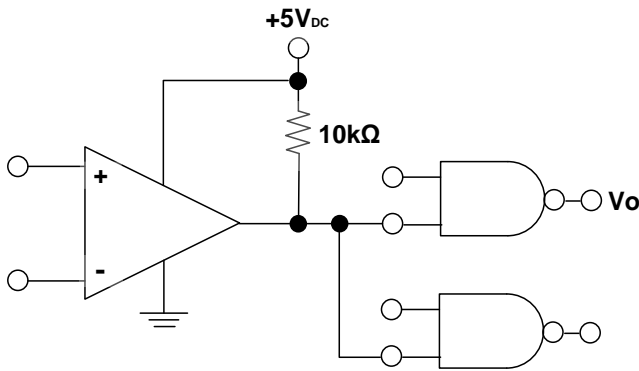

Driving TTL

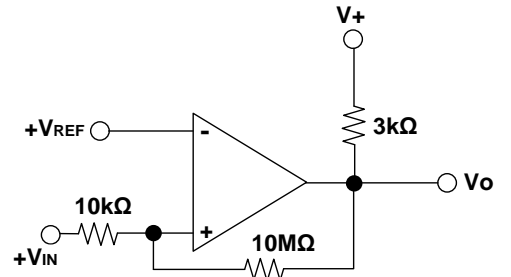

Non-Inverting Comparator with Hysteresis

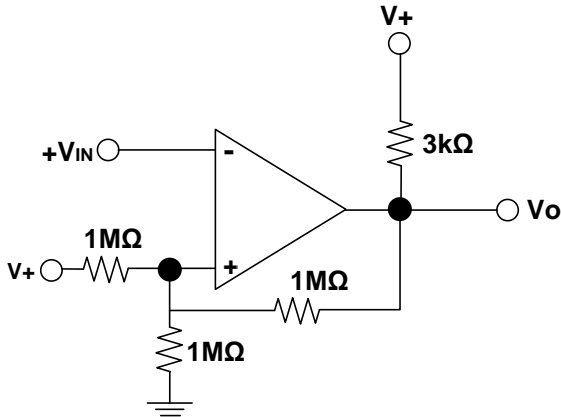

Inverting Comparator with Hysteresis

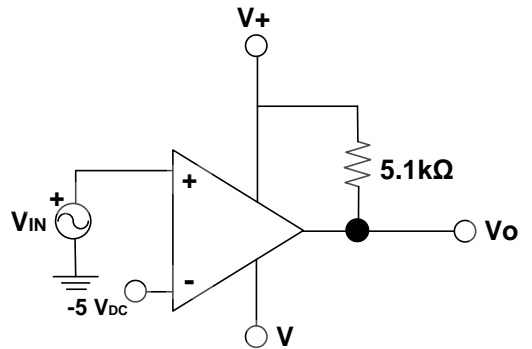

Comparator with a Negative Reference

Typical Application Circuit (continued) ($V_{CC} = 5.0V_{DC}$)

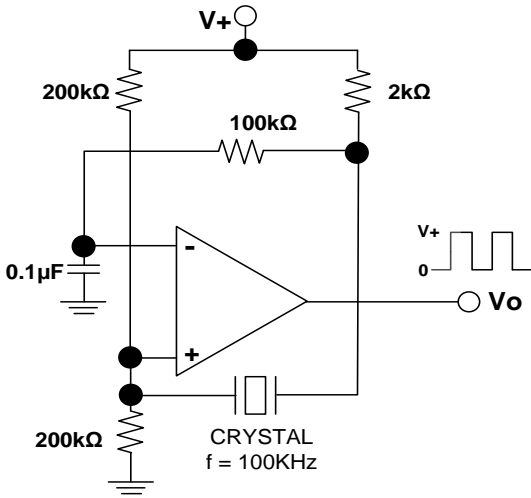

Crystal Controlled Oscillator

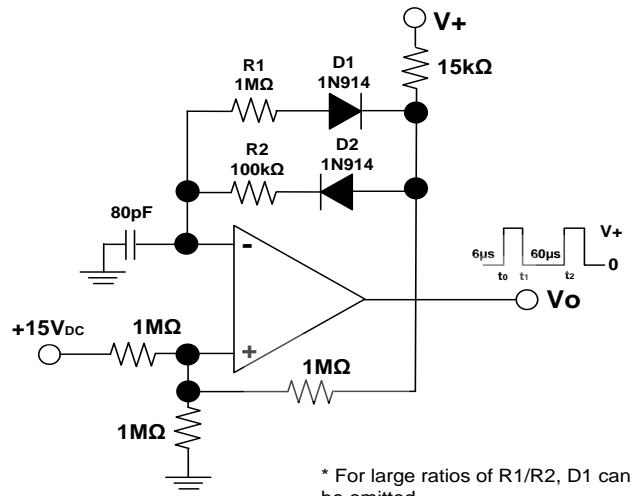

Pulse Generator
* For large ratios of R1/R2, D1 can be omitted.

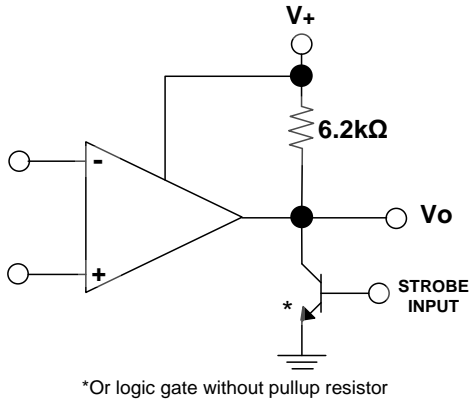

*Or logic gate without pullup resistor
Output Strobing

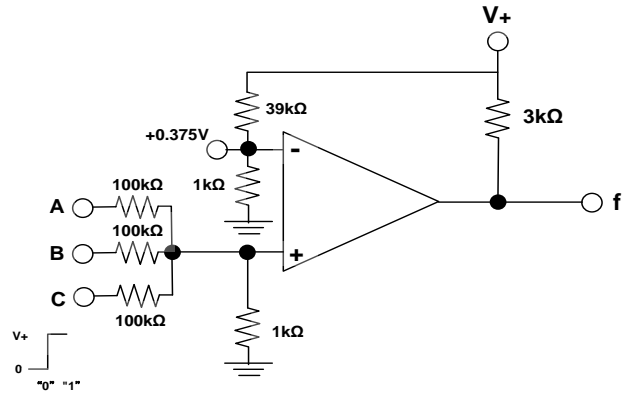

AND Gate

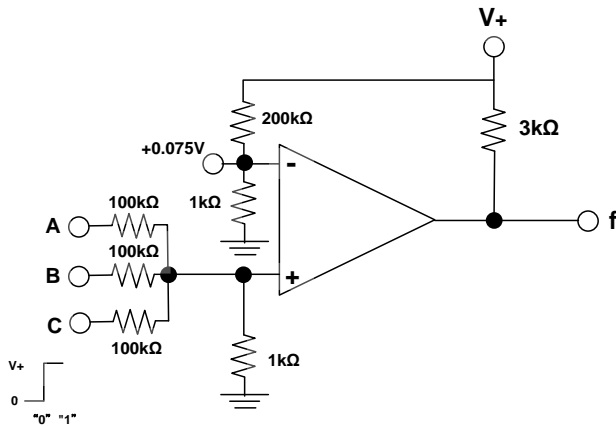

OR Gate

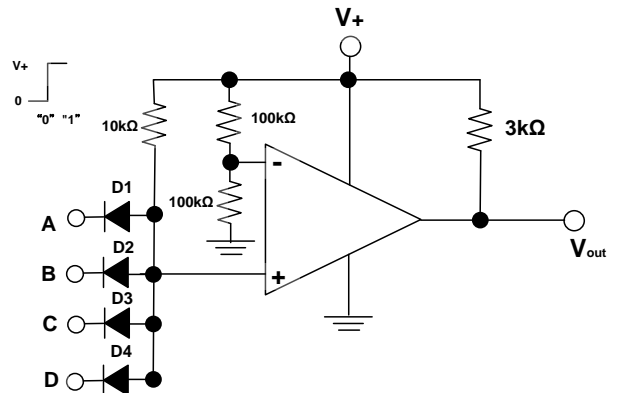

Large Fan-in AND Gate

Typical Application Circuit (continued) ($V_{CC} = 5.0V_{DC}$)

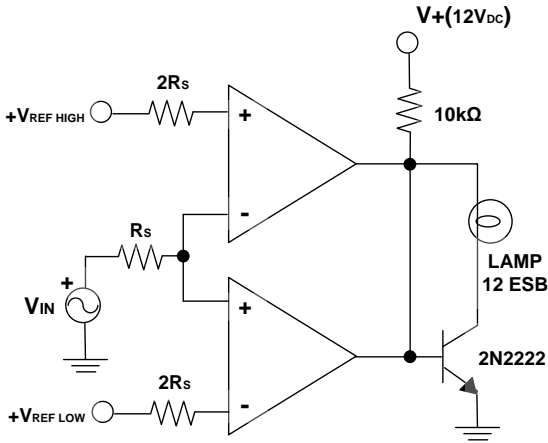

Limit Comparator

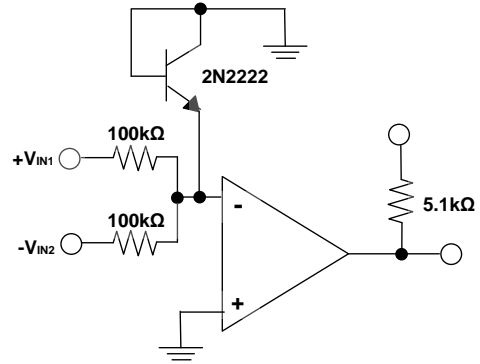

Comparing Input Voltage of Opposite Polarity

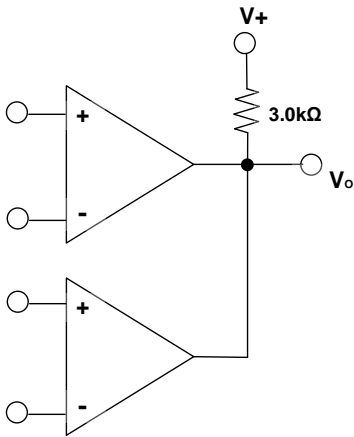

ORing the Outputs

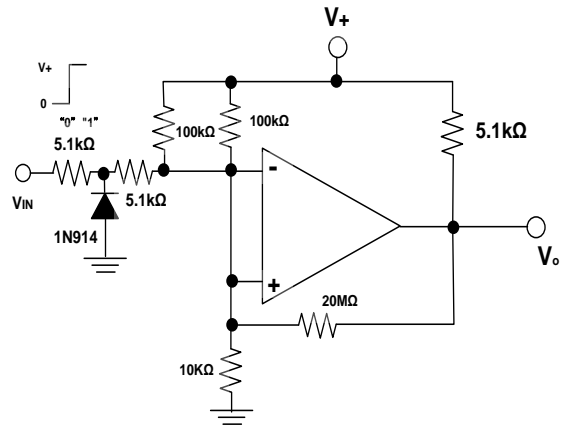

Zero Crossing Detector
(Single Power Supply)

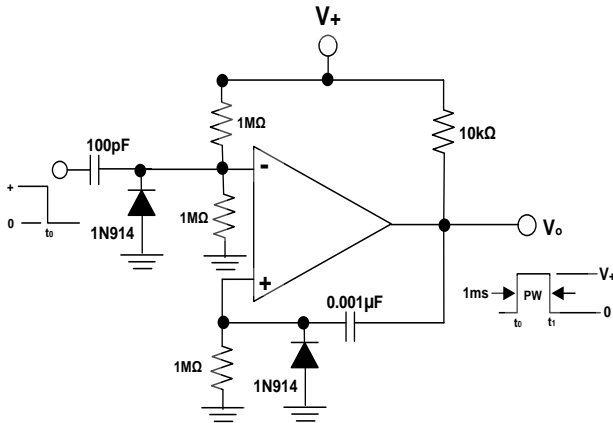

One-Shot Multivibrator

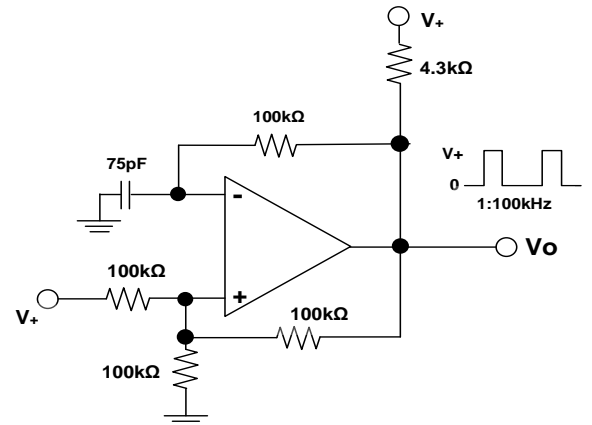

Squarewave Oscillator

Ordering Information

LM290X X Q XXX - XX

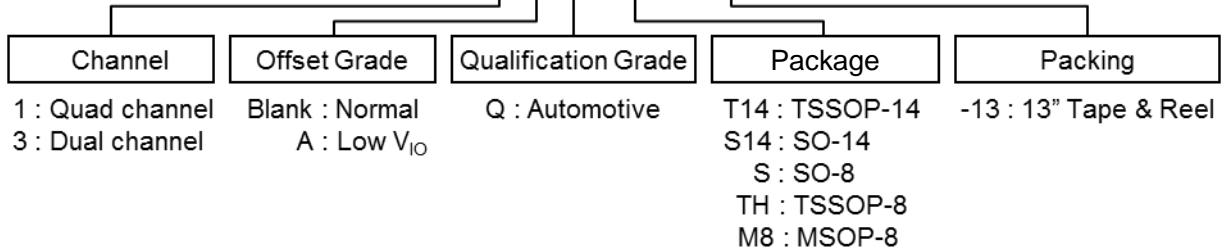

Part Number	Part Number Suffix	Package Code	Package (Note 15)	Packing	
				Qty.	Carrier
LM2901QT14-13	-13	T14	TSSOP-14	2,500	Tape & Reel
LM2901AQT14-13	-13	T14	TSSOP-14	2,500	Tape & Reel
LM2901QS14-13	-13	S14	SO-14	2,500	Tape & Reel
LM2901AQS14-13	-13	S14	SO-14	2,500	Tape & Reel
LM2903QS-13	-13	S	SO-8	2,500	Tape & Reel
LM2903AQS-13	-13	S	SO-8	2,500	Tape & Reel
LM2903QTH-13	-13	TH	TSSOP-8	2,500	Tape & Reel
LM2903AQTH-13	-13	TH	TSSOP-8	2,500	Tape & Reel
LM2903QM8-13	-13	M8	MSOP-8	2,500	Tape & Reel
LM2903AQM8-13	-13	M8	MSOP-8	2,500	Tape & Reel

Note: 15. For packaging details, go to our website at <https://www.diodes.com/design/support/packaging/diodes-packaging/>.

Marking Information

(1) TSSOP-14 and SO-14

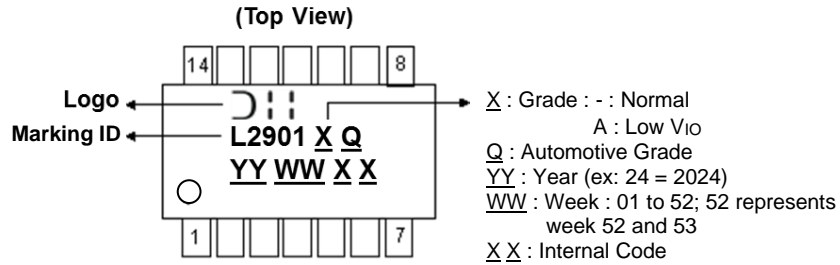

(2) SO-8

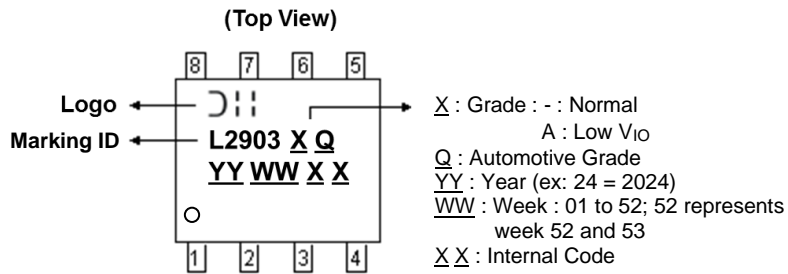

(3) MSOP-8 and TSSOP-8

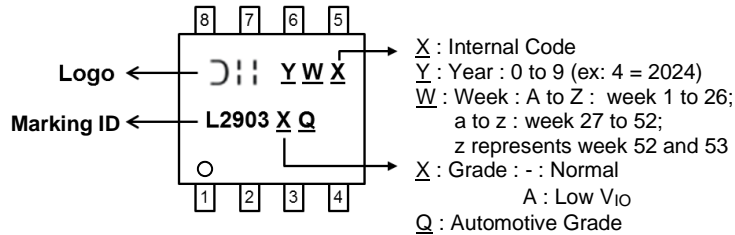

Package Outline Dimensions

Please see <http://www.diodes.com/package-outlines.html> for the latest version.

SO-14

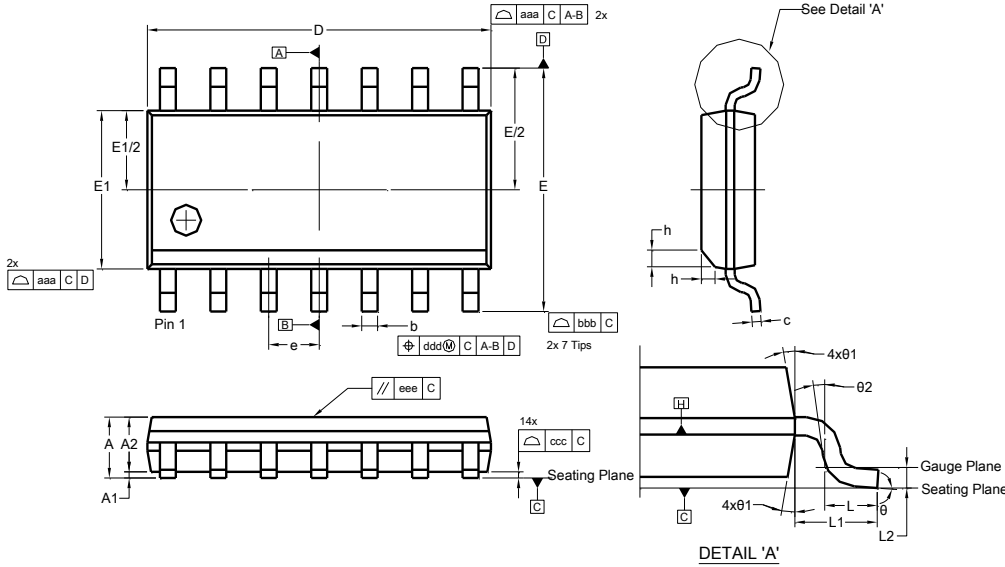

SO-14			
Dim	Min	Max	
A	--	1.75	--
A1	0.10	0.25	--
A2	1.25	1.55	--
b	0.31	0.51	--
c	0.10	0.25	--
D	8.55	8.75	--
E	5.80	6.20	--
E1	3.80	4.00	--
e	1.27 BSC		
h	0.25	0.50	--
L	0.40	1.27	--
L1	1.04 REF		
L2	0.25 BSC		
θ	0°	8°	--
θ1	5°	15°	--
θ2	0°	--	--
aaa	--	--	0.10
bbb	--	--	0.20
ccc	--	--	0.10
ddd	--	--	0.25
eee	--	--	0.10
All Dimensions in mm			

SO-8

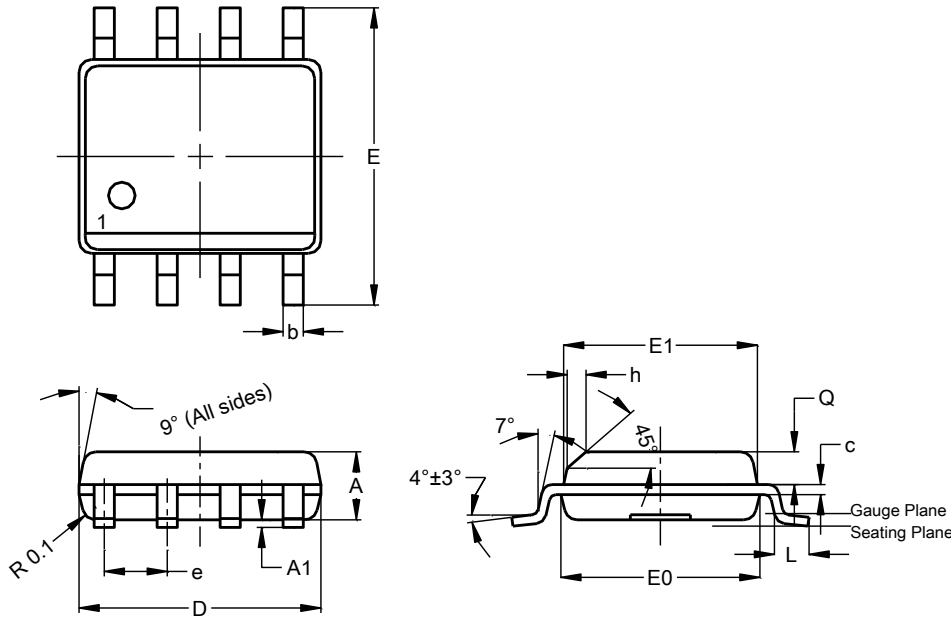

SO-8			
Dim	Min	Max	Typ
A	1.40	1.50	1.45
A1	0.10	0.20	0.15
b	0.30	0.50	0.40
c	0.15	0.25	0.20
D	4.85	4.95	4.90
E	5.90	6.10	6.00
E1	3.80	3.90	3.85
E0	3.85	3.95	3.90
e	--	--	1.27
h	--	--	0.35
L	0.62	0.82	0.72
Q	0.60	0.70	0.65
All Dimensions in mm			

Package Outline Dimensions (continued)

Please see <http://www.diodes.com/package-outlines.html> for the latest version.

TSSOP-14

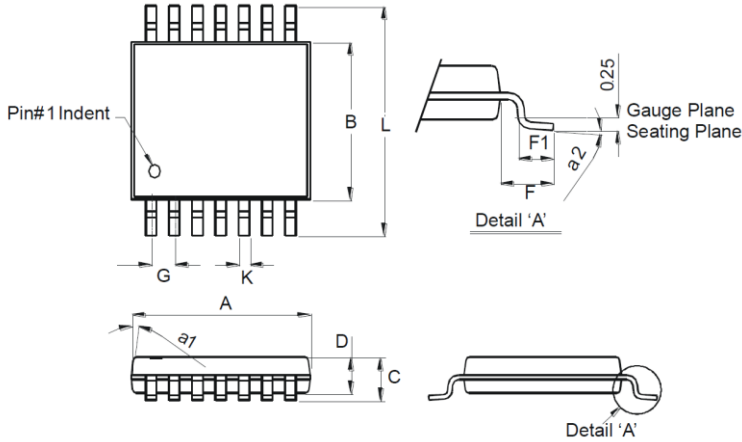

TSSOP-14		
Dim	Min	Max
a1	7° (4X)	
a2	0°	8°
A	4.9	5.10
B	4.30	4.50
C	—	1.2
D	0.8	1.05
F	1.00 Typ	
F1	0.45	0.75
G	0.65 Typ	
K	0.19	0.30
L	6.40 Typ	
All Dimensions in mm		

MSOP-8

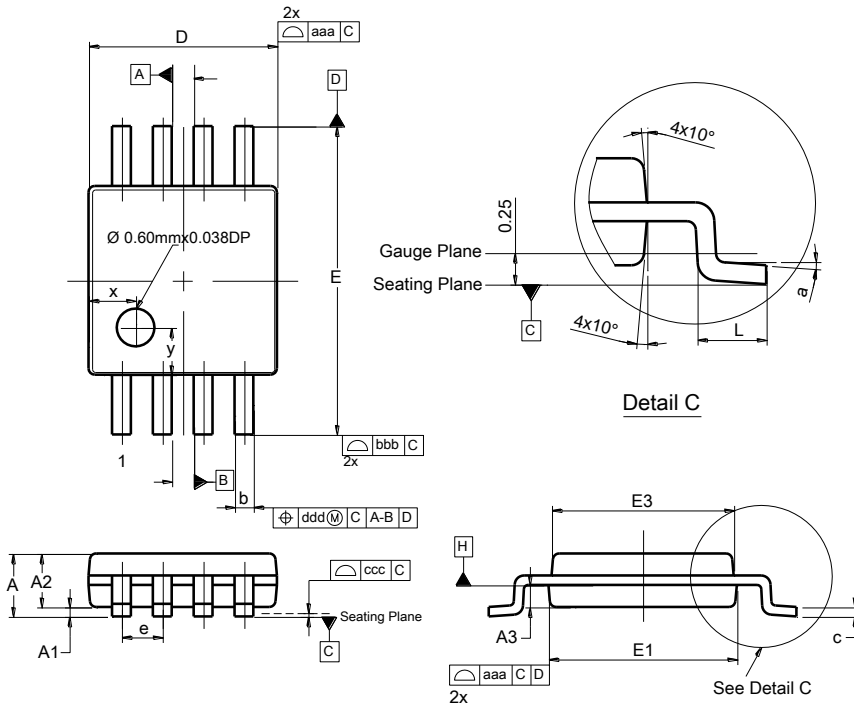

MSOP-8			
Dim	Min	Max	Typ
A	--	1.10	--
A1	0.05	0.15	0.10
A2	0.75	0.95	0.86
A3	0.29	0.49	0.39
b	0.22	0.38	0.30
c	0.08	0.23	0.15
D	2.90	3.10	3.00
E	4.70	5.10	4.90
E1	2.90	3.10	3.00
E3	2.85	3.05	2.95
e	--	--	0.65
L	0.40	0.80	0.60
a	0°	8°	4°
x	--	--	0.750
y	--	--	0.750
aaa	0.20		
bbb	0.25		
ccc	0.10		
ddd	0.13		
All Dimensions in mm			

Package Outline Dimensions (continued)

Please see <http://www.diodes.com/package-outlines.html> for the latest version.

TSSOP-8

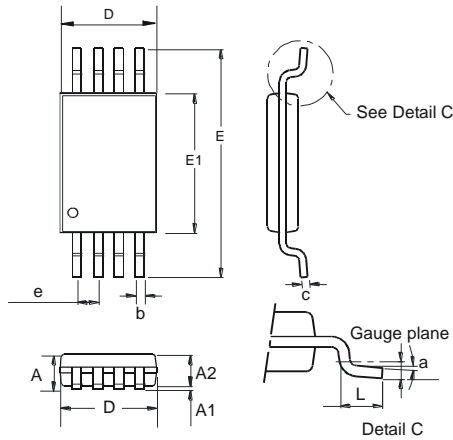

TSSOP-8			
Dim	Min	Max	Typ
a	0.09	–	–
A	–	1.20	–
A1	0.05	0.15	–
A2	0.825	1.025	0.925
b	0.19	0.30	–
c	0.09	0.20	–
D	2.90	3.10	3.025
e	–	–	0.65
E	–	–	6.40
E1	4.30	4.50	4.425
L	0.45	0.75	0.60
All Dimensions in mm			

Suggested Pad Layout

Please see <http://www.diodes.com/package-outlines.html> for the latest version.

SO-14

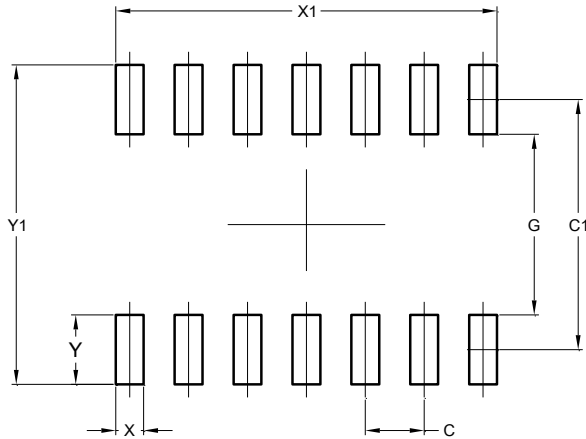

Dimensions	Value (in mm)
C	1.270
C1	5.400
G	3.900
X	0.600
X1	8.220
Y	1.500
Y1	6.900

SO-8

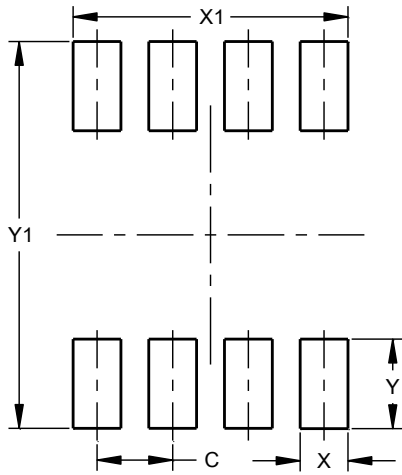

Dimensions	Value (in mm)
C	1.27
X	0.802
X1	4.612
Y	1.505
Y1	6.50

TSSOP-14

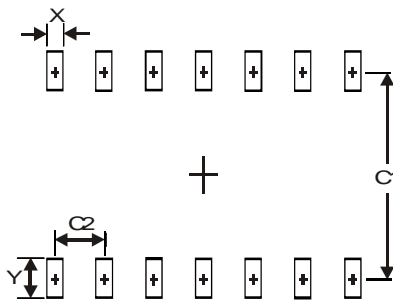

Dimensions	Value (in mm)
X	0.45
Y	1.45
C1	5.9
C2	0.65

Suggested Pad Layout (continued)

Please see <http://www.diodes.com/package-outlines.html> for the latest version.

MSOP-8

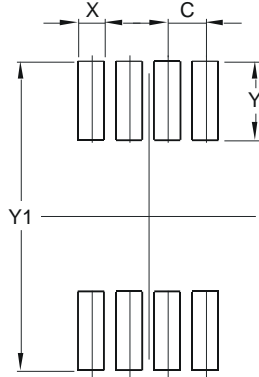

Dimensions	Value (in mm)
C	0.650
X	0.450
Y	1.350
Y1	5.300

TSSOP-8

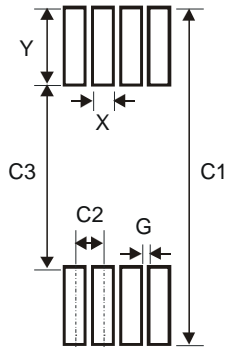

Dimensions	Value (in mm)
X	0.45
Y	1.78
C1	7.72
C2	0.65
C3	4.16
G	0.20

Mechanical Data

- Moisture Sensitivity: Level 1 per J-STD-020
- Terminals: Finish – Matte Tin Plated Leads, Solderable per MIL-STD-202, Method 208 (E3)
- Weight:
 - SO-8: 0.074 grams (Approximate)
 - SO-14: 0.14 grams (Approximate)
 - TSSOP-8: 0.041 grams (Approximate)
 - MSOP-8: 0.027 grams (Approximate)
 - TSSOP-14: 0.052 grams (Approximate)

IMPORTANT NOTICE

1. DIODES INCORPORATED (Diodes) AND ITS SUBSIDIARIES MAKE NO WARRANTY OF ANY KIND, EXPRESS OR IMPLIED, WITH REGARDS TO ANY INFORMATION CONTAINED IN THIS DOCUMENT, INCLUDING, BUT NOT LIMITED TO, THE IMPLIED WARRANTIES OF MERCHANTABILITY, FITNESS FOR A PARTICULAR PURPOSE OR NON-INFRINGEMENT OF THIRD PARTY INTELLECTUAL PROPERTY RIGHTS (AND THEIR EQUIVALENTS UNDER THE LAWS OF ANY JURISDICTION).
2. The Information contained herein is for informational purpose only and is provided only to illustrate the operation of Diodes' products described herein and application examples. Diodes does not assume any liability arising out of the application or use of this document or any product described herein. This document is intended for skilled and technically trained engineering customers and users who design with Diodes' products. Diodes' products may be used to facilitate safety-related applications; however, in all instances customers and users are responsible for (a) selecting the appropriate Diodes products for their applications, (b) evaluating the suitability of Diodes' products for their intended applications, (c) ensuring their applications, which incorporate Diodes' products, comply the applicable legal and regulatory requirements as well as safety and functional-safety related standards, and (d) ensuring they design with appropriate safeguards (including testing, validation, quality control techniques, redundancy, malfunction prevention, and appropriate treatment for aging degradation) to minimize the risks associated with their applications.
3. Diodes assumes no liability for any application-related information, support, assistance or feedback that may be provided by Diodes from time to time. Any customer or user of this document or products described herein will assume all risks and liabilities associated with such use, and will hold Diodes and all companies whose products are represented herein or on Diodes' websites, harmless against all damages and liabilities.
4. Products described herein may be covered by one or more United States, international or foreign patents and pending patent applications. Product names and markings noted herein may also be covered by one or more United States, international or foreign trademarks and trademark applications. Diodes does not convey any license under any of its intellectual property rights or the rights of any third parties (including third parties whose products and services may be described in this document or on Diodes' website) under this document.
5. Diodes' products are provided subject to Diodes' Standard Terms and Conditions of Sale (<https://www.diodes.com/about/company/terms-and-conditions/terms-and-conditions-of-sales/>) or other applicable terms. This document does not alter or expand the applicable warranties provided by Diodes. Diodes does not warrant or accept any liability whatsoever in respect of any products purchased through unauthorized sales channel.
6. Diodes' products and technology may not be used for or incorporated into any products or systems whose manufacture, use or sale is prohibited under any applicable laws and regulations. Should customers or users use Diodes' products in contravention of any applicable laws or regulations, or for any unintended or unauthorized application, customers and users will (a) be solely responsible for any damages, losses or penalties arising in connection therewith or as a result thereof, and (b) indemnify and hold Diodes and its representatives and agents harmless against any and all claims, damages, expenses, and attorney fees arising out of, directly or indirectly, any claim relating to any noncompliance with the applicable laws and regulations, as well as any unintended or unauthorized application.
7. While efforts have been made to ensure the information contained in this document is accurate, complete and current, it may contain technical inaccuracies, omissions and typographical errors. Diodes does not warrant that information contained in this document is error-free and Diodes is under no obligation to update or otherwise correct this information. Notwithstanding the foregoing, Diodes reserves the right to make modifications, enhancements, improvements, corrections or other changes without further notice to this document and any product described herein. This document is written in English but may be translated into multiple languages for reference. Only the English version of this document is the final and determinative format released by Diodes.
8. Any unauthorized copying, modification, distribution, transmission, display or other use of this document (or any portion hereof) is prohibited. Diodes assumes no responsibility for any losses incurred by the customers or users or any third parties arising from any such unauthorized use.
9. This Notice may be periodically updated with the most recent version available at <https://www.diodes.com/about/company/terms-and-conditions/important-notice>

The Diodes logo is a registered trademark of Diodes Incorporated in the United States and other countries.
All other trademarks are the property of their respective owners.
© 2024 Diodes Incorporated. All Rights Reserved.

www.diodes.com