

## Low-power, dual-voltage comparators



DFN8 2x2



MiniSO8



TSSOP8

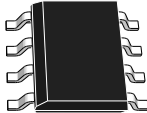

SO8

### Maturity status link

[LM193, LM293, LM393, LM393W](#)

### Features

- Wide single-supply voltage range or dual supplies: 2 V to 36 V or  $\pm 1$  V to  $\pm 18$  V
- Very low supply current (0.45 mA) independent of supply voltage (1 mW/comparator at 5 V)
- Low input bias current: 20 nA typ.
- Low input offset current:  $\pm 3$  nA typ.
- Low input offset voltage:  $\pm 1$  mV typ.
- Input common-mode voltage range includes ground
- Low output saturation voltage: 80 mV typ. ( $I_{\text{sink}} = 4$  mA)
- Differential input voltage range equal to the supply voltage
- TTL, DTL, ECL, MOS, CMOS compatible outputs
- Available in DFN8 2x2, MiniSO8, TSSOP8, and SO8 packages
- LM393W with internal ESD protection: 2 kV HBM

### Description

The [LM193](#), [LM293](#), [LM393](#) and [LM393W](#) devices consist of two independent low voltage comparators designed specifically to operate from a single supply over a wide range of voltages. Operation from split power supplies is also possible.

These comparators also have a unique characteristic in that the input common-mode voltage range includes ground even though operated from a single power supply voltage.

The [LM393W](#) offers additional ESD robustness of 2 kV HBM on all pins.



## 2 Package pin connections

Figure 3. Pin connections (top view)

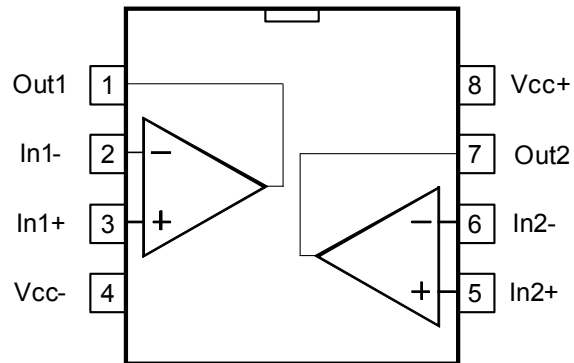

1. The exposed pad of the DFN8 2x2 can be left floating or connected to ground

### 3 Absolute maximum ratings and operating conditions

**Table 1. Absolute maximum ratings**

Symbol	Parameter	Value	Unit	
$V_{CC}$	Supply voltage	$\pm 18$ or 36	V	
$V_{id}$	Differential input voltage LM193, LM293, LM393 LM393W	$\pm 36$ $V_{CC-} - 0.3$ to $V_{CC+} + 0.3$		
$V_{in}$	Input voltage LM193, LM293, LM393 LM393W	-0.3 to 36 $V_{CC-} - 0.3$ to $V_{CC+} + 0.3$		
	Output short-circuit to ground <sup>(1)</sup>	Infinite		
$R_{thja}$	Thermal resistance junction to ambient <sup>(2)</sup>	DFN8 2x2	57	°C/W
		MiniSO8	190	
		TSSOP8	120	
		SO8	125	
$R_{thjc}$	Thermal resistance junction to case <sup>(2)</sup>	DFN8 2x2	—	
		MiniSO8	39	
		TSSOP8	37	
		SO8	40	
$T_j$	Maximum junction temperature	150	°C	
$T_{stg}$	Storage temperature range	-65 to 150		
ESD class <sup>(3)</sup> LM193, LM293, LM393	HBM: human body model <sup>(4)</sup>	H1B		
	MM: machine model <sup>(5)</sup>	M2		
	CDM: charged device model <sup>(6)</sup>	C5		
ESD class LM393W	HMB: human body model <sup>(7)</sup>	2000	V	
	MM: machine model	200		
	CDM: charged device mode <sup>(8)</sup>	1500		

1. Short-circuits from the output to  $V_{CC+}$  can cause excessive heating and potential destruction. The maximum output current is approximately 20 mA independent of the magnitude of  $V_{CC+}$ .
2. Short-circuits can cause excessive heating and destructive dissipation. Values are typical.
3. ESD class definition from AEC-Q100:
4. HBM class H1B: ESD voltage level from 500 V to 1000 V
5. MM class M2: ESD voltage level from 100 V to 200 V
6. CDM class C5: ESD voltage level greater than 1500 V.
7. JEDEC JESD22-A114F
8. JEDEC JESD22-101F

**Table 2. Operating conditions**

Symbol	Parameter		Value	Unit
$V_{CC}$	Supply voltage ( $V_{CC}^+$ ) - ( $V_{CC}^-$ )		2 to 36	
$V_{icm}$	Common mode input voltage range ( $V_{CC}^+ = 30\text{ V}$ )	$T_{amb} = 25\text{ °C}$	0 to ( $V_{CC}^+$ ) - 1.5	V
		$T_{min} \leq T_{amb} \leq T_{max}$	0 to ( $V_{CC}^+$ ) - 2	
$T_{oper}$	Operating free-air temperature range	LM193	-55 to 125	°C
		LM293, LM293A	-40 to 105	
		LM393, LM393A, LM393W	0 to 70	

## 4 Electrical characteristics

**Table 3.**  $V_{CC+} = 5\text{ V}$ ,  $V_{CC-} = 0\text{ V}$ ,  $T_{amb} = 25\text{ }^{\circ}\text{C}$  (unless otherwise specified)

Symbol	Parameter	Condition	LM293A, LM393A			LM193, LM293, LM393, LM393W			Unit
			Min.	Typ.	Max.	Min.	Typ.	Max.	
$V_{io}$	Input offset voltage <sup>(1)</sup>			1	2		1	5	mV
		$T_{min} \leq T_{amb} \leq T_{max}$			4			9	
$I_{io}$	Input offset current			3	25		3	50	nA
		$T_{min} \leq T_{amb} \leq T_{max}$			100			150	
$I_{ib}$	Input bias current ( $I^+$ or $I^-$ ) <sup>(2)</sup>			20	100		20	250	nA
		$T_{min} \leq T_{amb} \leq T_{max}$			300			400	
$A_{vd}$	Large signal voltage gain	$V_{CC} = 15\text{ V}$ , $R_L = 15\text{ k}\Omega$ , $V_o = 1\text{ V}$ to $11\text{ V}$	50	200		50	200		V/mV
$I_{CC}$	Supply current (all comparators)	$V_{CC} = 5\text{ V}$ , no load		0.45	1		0.45	1	mA
		$V_{CC} = 30\text{ V}$ , no load		0.6	2.5		0.6	2.5	
$V_{id}$	Differential input voltage <sup>(3)</sup>				$V_{CC}^+$			$V_{CC}^+$	
$V_{OL}$	Low-level output voltage	$V_{id} = -1\text{ V}$ , $I_{sink} = 4\text{ mA}$		80	400		80	400	mV
		$T_{min} \leq T_{amb} \leq T_{max}$			700			700	
$I_{OH}$	High-level output current	$V_{CC} = V_o = 30\text{ V}$ , $V_{id} = 1\text{ V}$		0.1			0.1		nA
		$T_{min} \leq T_{amb} \leq T_{max}$			1			1	$\mu\text{A}$
$I_{sink}$	Output sink current	$V_{id} = 1\text{ V}$ , $V_o = 1.5\text{ V}$	6	18		6	18		mA
$t_{re}$	Response time <sup>(4)</sup>	$R_L = 5.1\text{ k}\Omega$ connected to $V_{CC}^+$		1.3			1.3		$\mu\text{s}$
$t_{rel}$	Large signal response time	$R_L = 5.1\text{ k}\Omega$ connected to $V_{CC}^+$ , $e_l = \text{TTL}$ , $V_{(ref)} = 1.4\text{ V}$		300			300		ns

- At output switch point,  $V_o = 1.4\text{ V}$ ,  $R_s = 0$  with  $V_{CC}^+$  from  $5\text{ V}$  to  $30\text{ V}$ , and over the full common-mode range ( $0\text{ V}$  to  $(V_{CC}^+) - 1.5\text{ V}$ ).
- The direction of the input current is out of the IC due to the PNP input stage. This current is essentially constant, independent of the state of the output, so no loading charge exists on the reference of input lines.
- Positive excursions of input voltage may exceed the power supply level. As long as the other voltage remains within the common-mode range, the comparator will provide a proper output state. The low input voltage state must not be less than  $-0.3\text{ V}$  (or  $0.3\text{ V}$  below the negative power supply, if used).
- The response time specified is for a  $100\text{ mV}$  input step with  $5\text{ mV}$  overdrive. For larger overdrive signals,  $300\text{ ns}$  can be obtained.

## 5 Electrical characteristic curves

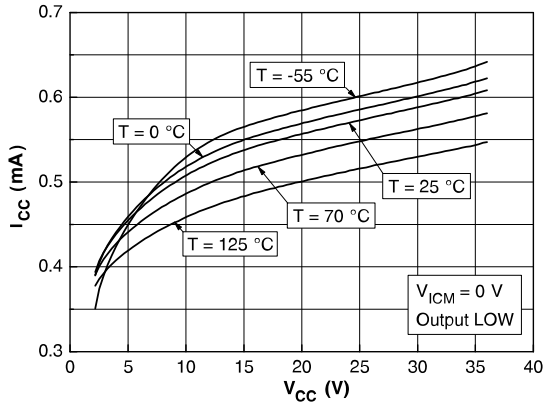
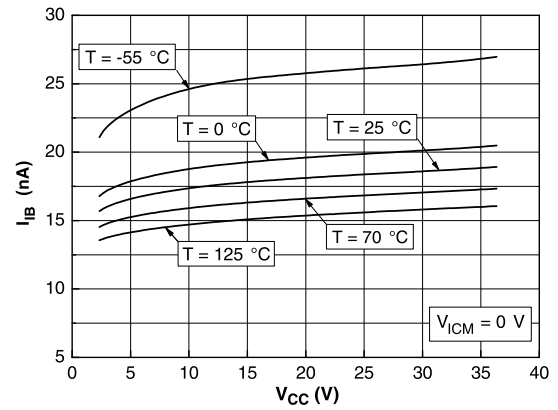
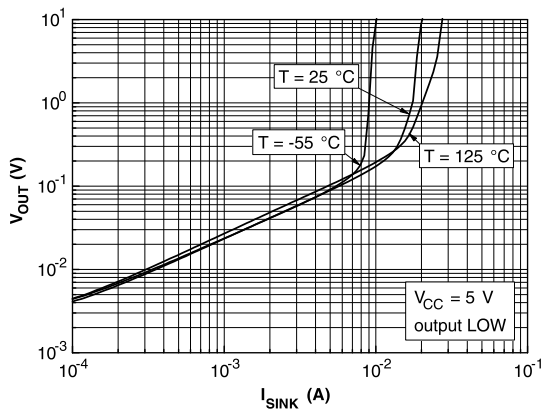
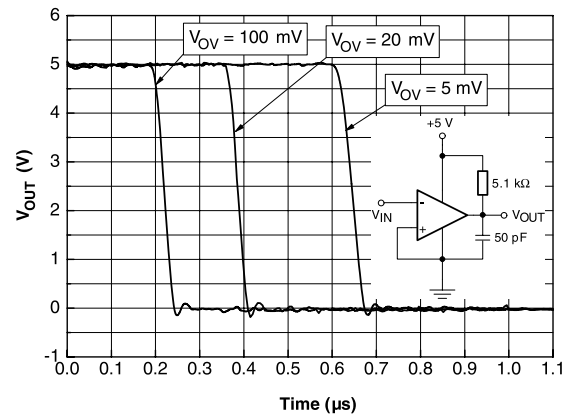
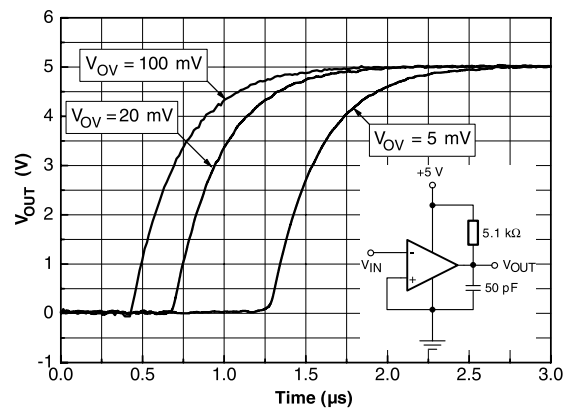
**Figure 4. Supply current vs. supply voltage**

**Figure 5. Input current vs. supply voltage**

**Figure 6. Output saturation voltage vs. output current**

**Figure 7. Response time for various input overdrives - negative transition**

**Figure 8. Response time for various input overdrives - positive transition**

## 6 Typical applications

Figure 9. Basic comparator

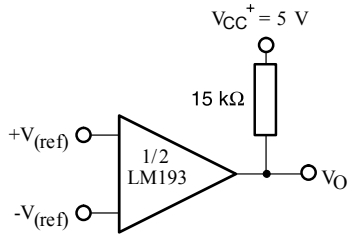

Figure 10. Driving TTL

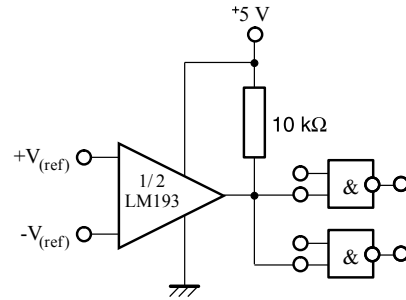

Figure 11. Low-frequency op amp (1)

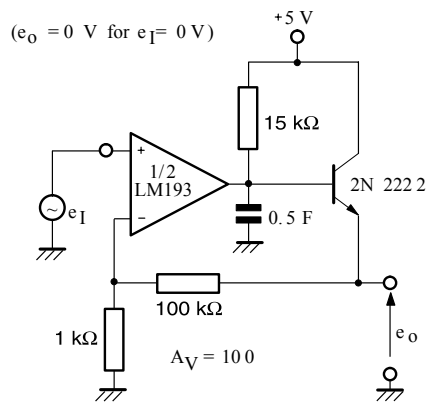

Figure 12. Driving CMOS

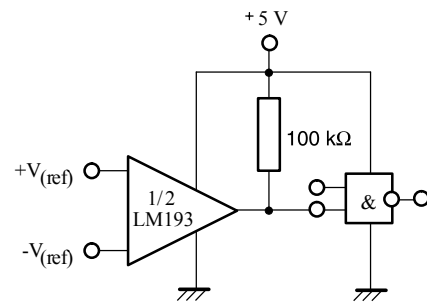

Figure 13. Low-frequency op amp (2)

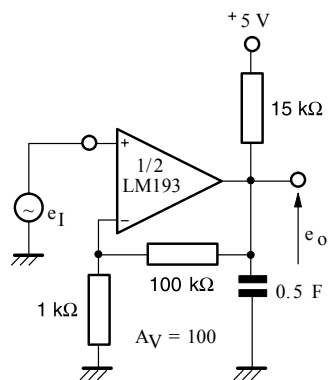
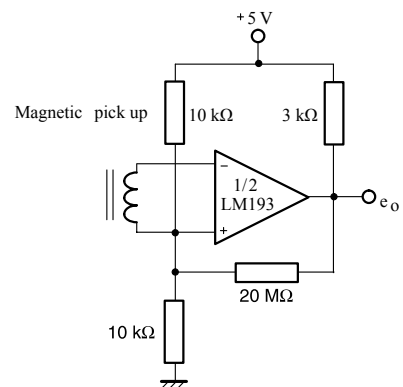
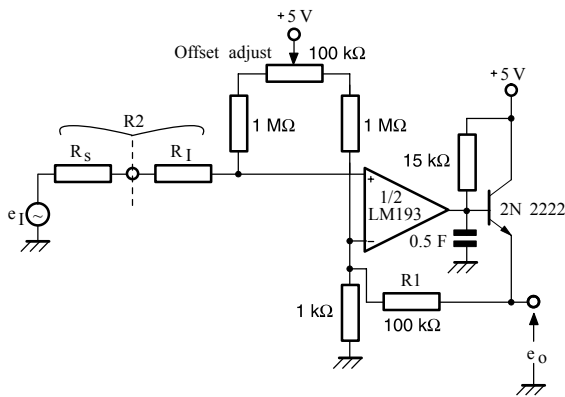
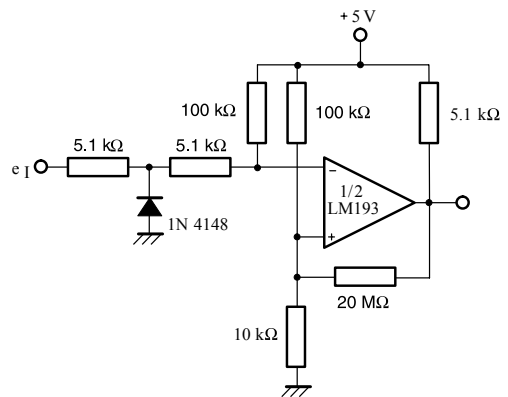
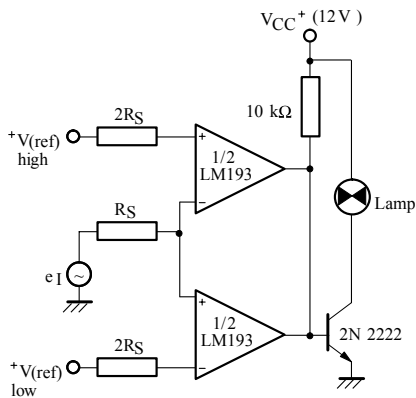
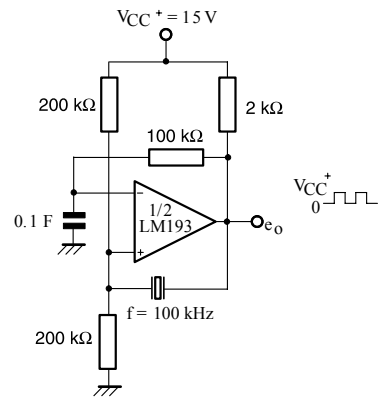
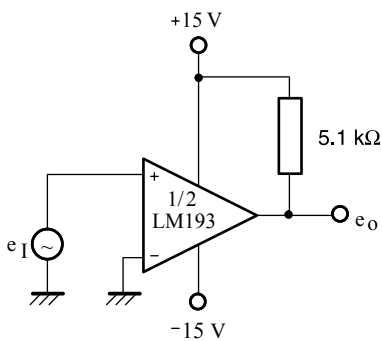
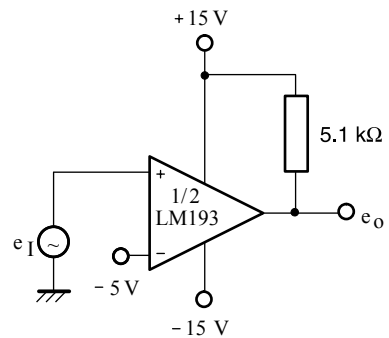
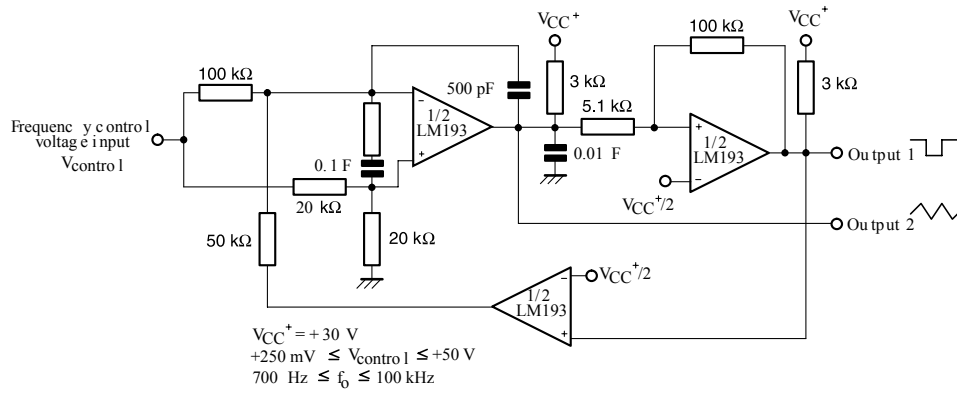

Figure 14. Transducer amplifier



**Figure 15. Low-frequency op amp with offset adjust**

**Figure 16. Zero crossing detector (single power supply)**

**Figure 17. Limit comparator**

**Figure 18. Crystal controlled comparator**

**Figure 19. Split supply applications (zero crossing detector)**

**Figure 20. Comparator with a negative reference**

**Figure 21. Two-decade, high-frequency VCO**

## 7 Package information

In order to meet environmental requirements, ST offers these devices in different grades of **ECOPACK** packages, depending on their level of environmental compliance. ECOPACK specifications, grade definitions and product status are available at: [www.st.com](http://www.st.com). ECOPACK is an ST trademark.

### 7.1 DFN8 2 x 2 package information

**Figure 22. DFN8 2 x 2 package outline**

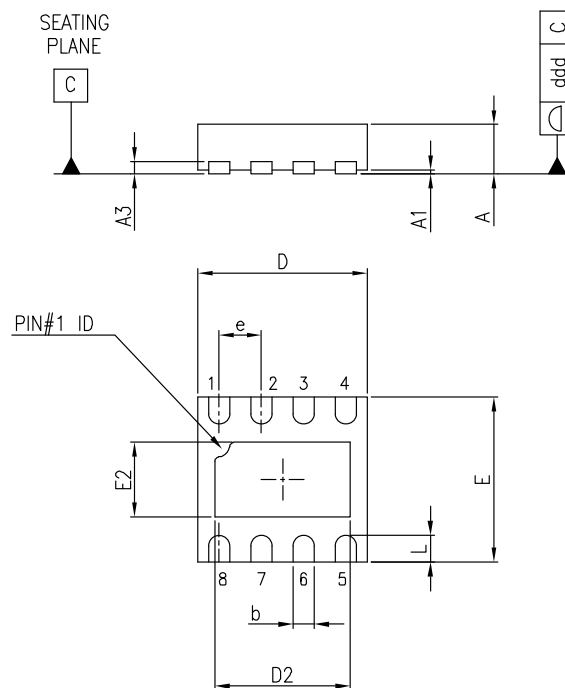

**Table 4. DFN8 2 x 2 mechanical data**

Ref.	Dimensions					
	Millimeters			Inches		
	Min.	Typ.	Max.	Min.	Typ.	Max.
A	0.51	0.55	0.60	0.020	0.022	0.024
A1			0.05			0.002
A3		0.15			0.006	
b	0.18	0.25	0.30	0.007	0.010	0.012
D	1.85	2.00	2.15	0.073	0.079	0.085
D2	1.45	1.60	1.70	0.057	0.063	0.067
E	1.85	2.00	2.15	0.073	0.079	0.085
E2	0.75	0.90	1.00	0.030	0.035	0.039
e		0.50			0.020	
L	0.225	0.325	0.425	0.009	0.013	0.017
ddd			0.08			0.003

Figure 23. DFN8 2 x 2 recommended footprint

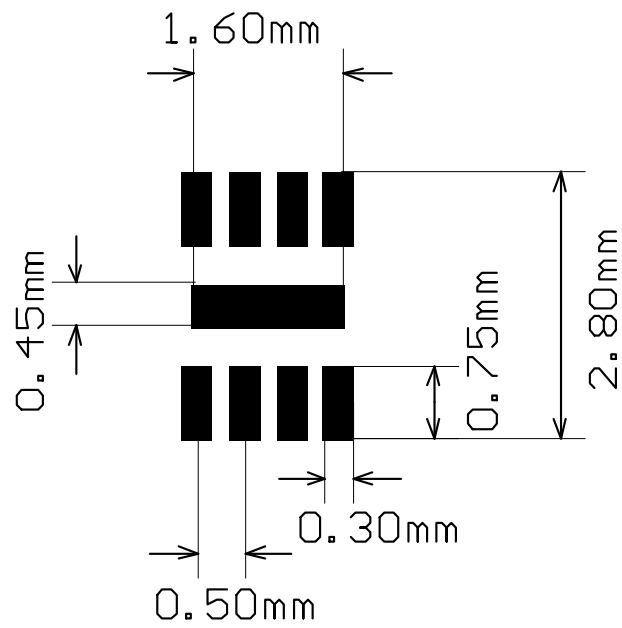

## 7.2 MiniSO8 package information

Figure 24. MiniSO8 package outline

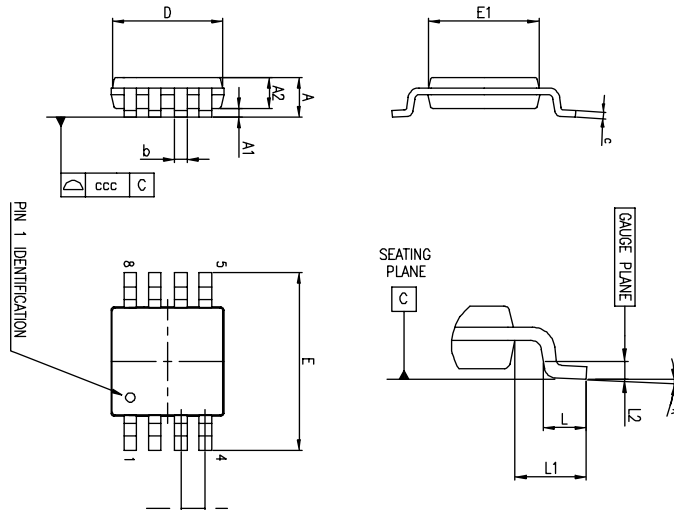

Table 5. MiniSO8 package mechanical data

Ref.	Dimensions					
	Millimeters			Inches		
	Min.	Typ.	Max.	Min.	Typ.	Max.
A			1.1			0.043
A1	0		0.15	0		0.0006
A2	0.75	0.85	0.95	0.030	0.033	0.037
b	0.22		0.40	0.009		0.016
c	0.08		0.23	0.003		0.009
D	2.80	3.00	3.20	0.11	0.118	0.126
E	4.65	4.90	5.15	0.183	0.193	0.203
E1	2.80	3.00	3.10	0.11	0.118	0.122
e		0.65			0.026	
L	0.40	0.60	0.80	0.016	0.024	0.031
L1		0.95			0.037	
L2		0.25			0.010	
k	0°		8°	0°		8°
ccc			0.10			0.004

### 7.3 TSSOP8 package information

Figure 25. TSSOP8 package outline

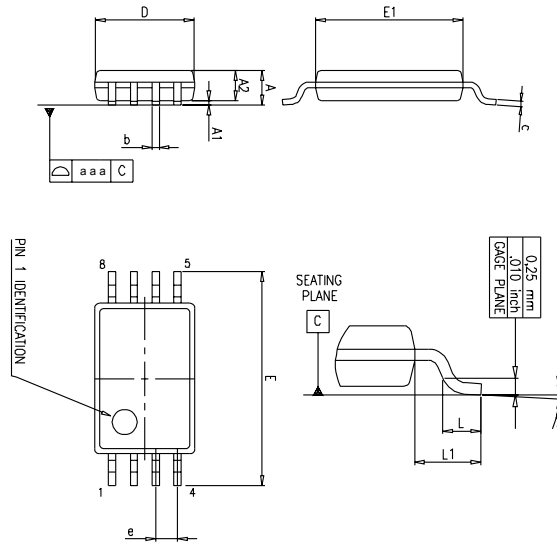

Table 6. TSSOP8 package mechanical data

Ref.	Dimensions					
	Millimeters			Inches		
	Min.	Typ.	Max.	Min.	Typ.	Max.
A			1.20			0.047
A1	0.05		0.15	0.002		0.006
A2	0.80	1.00	1.05	0.031	0.039	0.041
b	0.19		0.30	0.007		0.012
c	0.09		0.20	0.004		0.008
D	2.90	3.00	3.10	0.114	0.118	0.122
E	6.20	6.40	6.60	0.244	0.252	0.260
E1	4.30	4.40	4.50	0.169	0.173	0.177
e		0.65			0.0256	
k	0°		8°	0°		8°
L	0.45	0.60	0.75	0.018	0.024	0.030
L1		1			0.039	
aaa		0.10			0.004	

## 7.4 SO8 package information

Figure 26. SO8 package outline

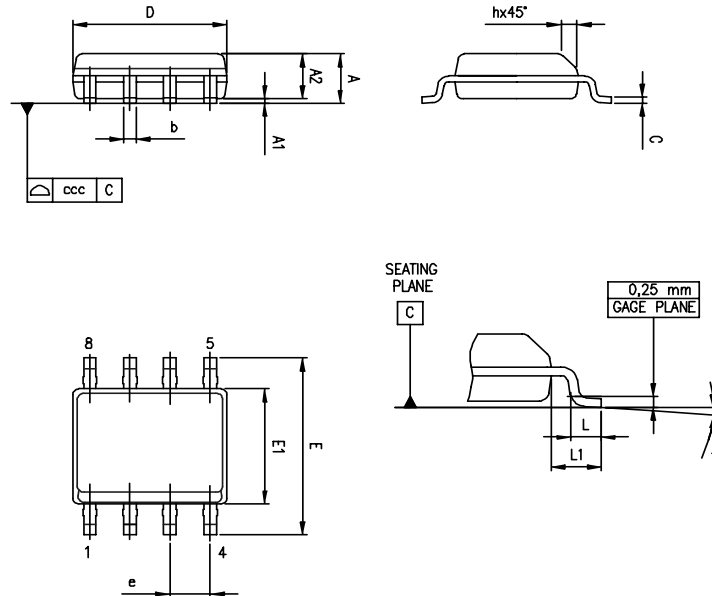

Table 7. SO8 package mechanical data

Ref.	Dimensions					
	Millimeters			Inches		
	Min.	Typ.	Max.	Min.	Typ.	Max.
A			1.75			0.069
A1	0.10		0.25	0.004		0.010
A2	1.25			0.049		
b	0.28		0.48	0.011		0.019
c	0.17		0.23	0.007		0.010
D	4.80	4.90	5.00	0.189	0.193	0.197
E	5.80	6.00	6.20	0.228	0.236	0.244
E1	3.80	3.90	4.00	0.150	0.154	0.157
e		1.27			0.050	
h	0.25		0.50	0.010		0.020
L	0.40		1.27	0.016		0.050
L1		1.04			0.040	
k	0°		8°	0°		8°
ccc			0.10			0.004

## 8 Ordering information

**Table 8. Ordering information**

Order code	Temperature range	Package	Packing	Marking
LM193DT	-55 °C to 125 °C	SO8	Tape and reel	193
LM193QT		DFN8 2x2		K57
LM293ADT	-40 °C to 105 °C	SO8		Tube
LM293D			Tape and reel	293
LM293DT				
LM293PT		TSSOP8		
LM293ST		MiniSO8		K512
LM293QT		DFN8 2x2		K59
LM393ADT		0 °C to 70 °C	SO8	Tube
LM393D	Tape and reel			393
LM393DT				
LM393WDT			393W	
LM393PT			TSSOP8	393
LM393ST			MiniSO8	M393
LM393QT	DFN8 2x2		K5B	

## Revision history

**Table 9. Document revision history**

Date	Revision	Changes
02-Jul-2002	1	First release.
02-Jan-2005	2	Class A of the product included in the datasheet.
02-May-2005	3	PPAP references inserted in the datasheet, see Table 7: Ordering information on page 18.
02-Jul-2005	4	Modification on PPAP references - Errors on part numbers, see Table 7: Ordering information on page 18.
22-Nov-2005	5	Modification on Table 3 on page 6. LM293,A must be -40/+105°C instead of -40/+125°C.
16-Feb-2006	6	Unit error for $V_{OI}$ parameter see Table 3 on page 6.
23-Aug-2007	7	Corrected error in DIP8 package information related to lead thickness, see Figure 21 on page 12. Added values for $R_{thja}$ and $R_{thjc}$ , and ESD parameters in Table 1: Absolute maximum ratings.
08-Nov-2007	8	Updated MiniSO-8 package information. Reformatted package information. Added automotive grade order codes.
19-Feb-2008	9	Corrected error in SO-8 package mechanical data: E dimension in drawing was marked with an F in table.
15-Dec-2008	10	Corrected heading in Figure 5.
22-Feb-2010	11	Deleted automotive grade order codes for LM293 and LM393.
22-Jun-2011	12	Updated typical performance curves. Updated typical values on Table 3 on page 6. Updated ESD parameters with ESD classes in Table 1: Absolute maximum ratings. Added DFN8 2x2mm package mechanical drawing. Added DFN8 2x2mm recommended footprint. Added DFN8 2x2mm order codes in Table 9.
27-Jun-2012	13	Updated Features (added package information), Description (added RPNs), Figure 1: Pin connections (top view) moved to page 3, added Contents, updated marking of the LM293QT device in Table 9, minor text corrections throughout document.
18-Jan-2013	14	Updated Table 8 (added dimensions in inches).
09-Feb-2016	15	Updated document layout. Removed DIP8 package. Section Features: removed "plastic micropackage" from the DFN8 2x2, MiniSO8, and SO8 silhouettes; removed "thin shrink small outline package" from the TSSOP8 silhouette. Figure 4. Figure 2: added footnote about the exposed pad of the DFN8 2x2. Table 4: updated "L" value Section 7.3 Table 6: "aaa" value is a typ. value not a max. value Section 7.4 Table 7: updated min. "k" millimeters value Table 8: removed following obsolete order codes: LM193AD, LM193D, LM193AN, LM193N, LM293AD, LM293AN, LM293N, LM393AD, LM393AN, LM393N; added footnote (not recommended for new design) to order code LM193ADT; replaced marking of LM393QT with "K5B" instead of "K5C".
29-Aug-2022	16	Updated features and description on the cover page, Table 1, Figure 5 and Section 8. Added new Figure 3.
01-Oct-2022	17	Updated Table 8. Ordering information.

**IMPORTANT NOTICE – READ CAREFULLY**

STMicroelectronics NV and its subsidiaries (“ST”) reserve the right to make changes, corrections, enhancements, modifications, and improvements to ST products and/or to this document at any time without notice. Purchasers should obtain the latest relevant information on ST products before placing orders. ST products are sold pursuant to ST’s terms and conditions of sale in place at the time of order acknowledgment.

Purchasers are solely responsible for the choice, selection, and use of ST products and ST assumes no liability for application assistance or the design of purchasers’ products.

No license, express or implied, to any intellectual property right is granted by ST herein.

Resale of ST products with provisions different from the information set forth herein shall void any warranty granted by ST for such product.

ST and the ST logo are trademarks of ST. For additional information about ST trademarks, refer to [www.st.com/trademarks](http://www.st.com/trademarks). All other product or service names are the property of their respective owners.

Information in this document supersedes and replaces information previously supplied in any prior versions of this document.

© 2022 STMicroelectronics – All rights reserved