

3A, 20V - 200V Schottky Barrier Surface Mount Rectifier

FEATURES

- Low power loss, high efficiency
- Ideal for automated placement
- Guard ring for overvoltage protection
- High surge current capability
- Moisture sensitivity level: level 1, per J-STD-020
- RoHS Compliant
- Halogen-free

APPLICATIONS

- Switching mode power supply (SMPS)
- Adapters
- Lighting application
- Converter

MECHANICAL DATA

- Case: DO-214AB (SMC)
- Molding compound meets UL 94V-0 flammability rating
- Terminal: Matte tin plated leads, solderable per J-STD-002
- Meet JESD 201 class 2 whisker test
- Polarity: Indicated by cathode band
- Weight: 0.210g (approximately)

KEY PARAMETERS		
PARAMETER	VALUE	UNIT
I_F	3	A
V_{RRM}	20 - 200	V
I_{FSM}	75, 100	A
$T_{J\ MAX}$	125, 150	°C
Package	DO-214AB (SMC)	
Configuration	Single die	



DO-214AB (SMC)



ABSOLUTE MAXIMUM RATINGS ($T_A = 25^\circ\text{C}$ unless otherwise noted)											
PARAMETER	SYMBOL	SS 32	SS 33	SS 34	SS 35	SS 36	SS 39	SS 310	SS 315	SS 320	UNIT
Repetitive peak reverse voltage	V_{RRM}	20	30	40	50	60	90	100	150	200	V
Reverse voltage, total rms value	$V_{R(RMS)}$	14	21	28	35	42	63	70	105	140	V
Forward current	I_F	3									A
Peak forward surge current, 8.3ms single half sine-wave superimposed on rated load	I_{FSM}	100				75					A
Critical rate of rise of off-state voltage	dV/dt	10,000									V/ μs
Junction temperature	T_J	- 55 to +125				- 55 to +150					°C
Storage temperature	T_{STG}	- 55 to +150									°C

THERMAL PERFORMANCE			
PARAMETER	SYMBOL	TYP	UNIT
Junction-to-lead thermal resistance	$R_{\theta JL}$	13	°C/W
Junction-to-ambient thermal resistance	$R_{\theta JA}$	52	°C/W
Junction-to-Lead thermal resistance	$R_{\theta JC}$	14	°C/W

Thermal Performance Note: Units mounted on PCB (16mm x 16mm Cu pad test board)

ELECTRICAL SPECIFICATIONS ($T_A = 25^\circ\text{C}$ unless otherwise noted)						
PARAMETER		CONDITIONS	SYMBOL	TYP	MAX	UNIT
Forward voltage ⁽¹⁾	SS32 SS33 SS34	$I_F = 3\text{A}, T_J = 25^\circ\text{C}$	V_F	-	0.50	V
	SS35 SS36			-	0.75	V
	SS39 SS310			-	0.85	V
	SS315 SS320			-	0.95	V
	SS32 SS33 SS34	$I_F = 3\text{A}, T_J = 100^\circ\text{C}$		-	0.40	V
	SS35 SS36			-	0.65	V
	SS39 SS310			-	0.70	V
	SS315 SS320			-	0.80	V

ELECTRICAL SPECIFICATIONS ($T_A = 25^\circ\text{C}$ unless otherwise noted)						
PARAMETER		CONDITIONS	SYMBOL	TYP	MAX	UNIT
Reverse current @ rated $V_R^{(2)}$	SS32 SS33 SS34 SS35 SS36	$T_J = 25^\circ\text{C}$	I_R	-	0.5	mA
	SS39 SS310 SS315 SS320			-	0.1	mA
	SS32 SS33 SS34	$T_J = 100^\circ\text{C}$		-	10	mA
	SS35 SS36			-	5	mA
	SS39 SS310 SS315 SS320			-	-	mA
	SS32 SS33 SS34	$T_J = 125^\circ\text{C}$		-	-	mA
	SS35 SS36			-	-	mA
	SS39 SS310 SS315 SS320			-	0.5	mA

Notes:

1. Pulse test with $PW = 0.3\text{ms}$
2. Pulse test with $PW = 30\text{ms}$

ORDERING INFORMATION			
ORDERING CODE	PACKAGE	PACKING	DEVICE MARKING
SS32	DO-214AB (SMC)	3,000 / Tape & Reel	SS32
SS33	DO-214AB (SMC)	3,000 / Tape & Reel	SS33
SS34	DO-214AB (SMC)	3,000 / Tape & Reel	SS34
SS35	DO-214AB (SMC)	3,000 / Tape & Reel	SS35
SS36	DO-214AB (SMC)	3,000 / Tape & Reel	SS36
SS39	DO-214AB (SMC)	3,000 / Tape & Reel	SS39
SS310	DO-214AB (SMC)	3,000 / Tape & Reel	SS310
SS315	DO-214AB (SMC)	3,000 / Tape & Reel	SS315
SS320	DO-214AB (SMC)	3,000 / Tape & Reel	SS320

CHARACTERISTICS CURVES

($T_A = 25^\circ\text{C}$ unless otherwise noted)

Fig.1 Forward Current Derating Curve

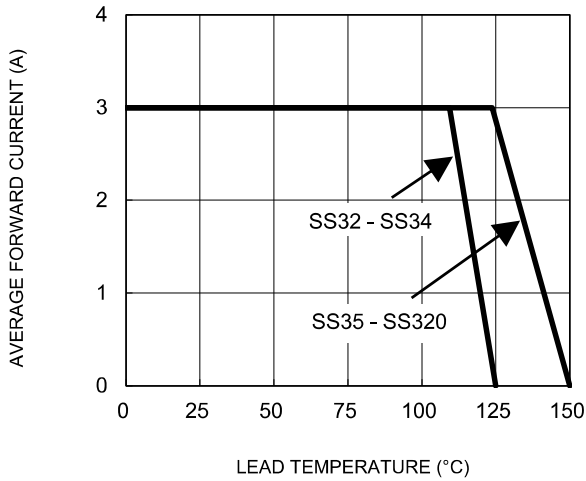

Fig.2 Typical Junction Capacitance

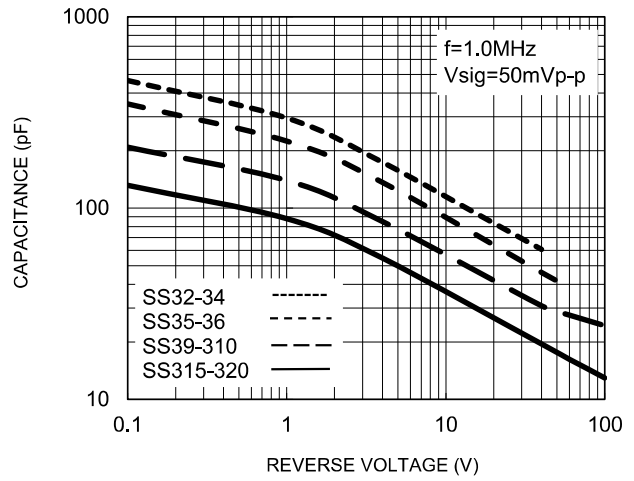

Fig.3 Typical Reverse Characteristics

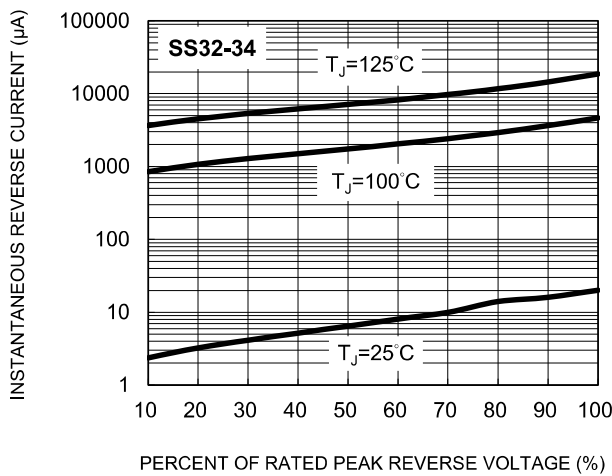

Fig.4 Typical Forward Characteristics

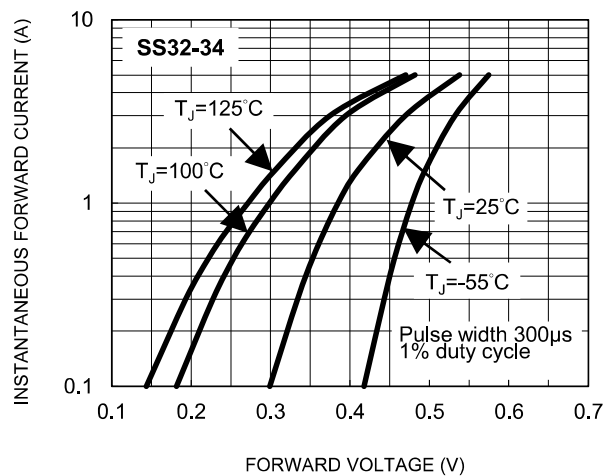

Fig.5 Typical Reverse Characteristics

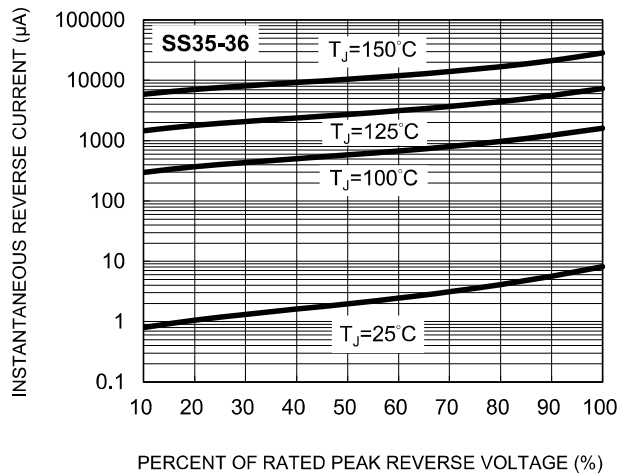
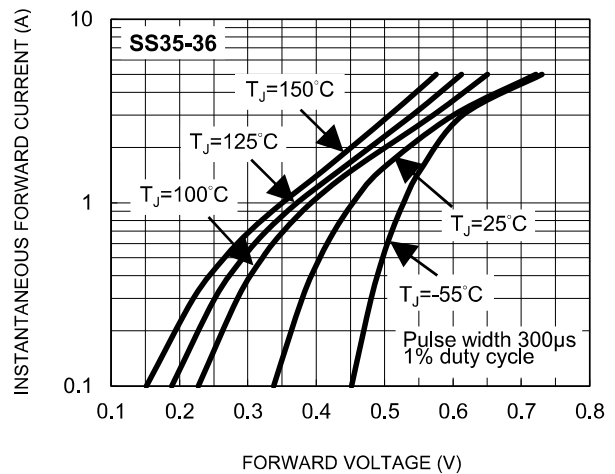

Fig.6 Typical Forward Characteristics



CHARACTERISTICS CURVES

($T_A = 25^\circ\text{C}$ unless otherwise noted)

Fig.7 Typical Reverse Characteristics

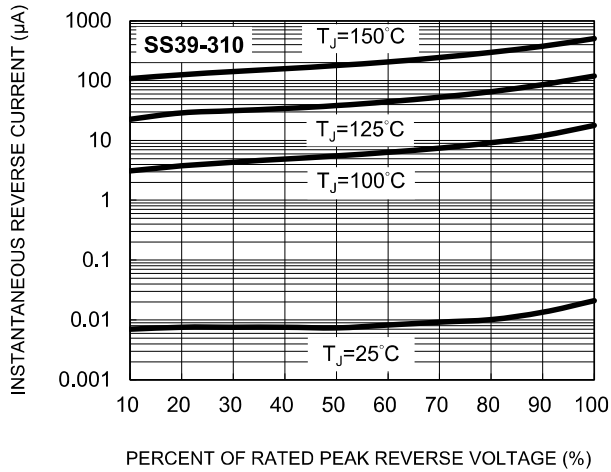

Fig.8 Typical Forward Characteristics

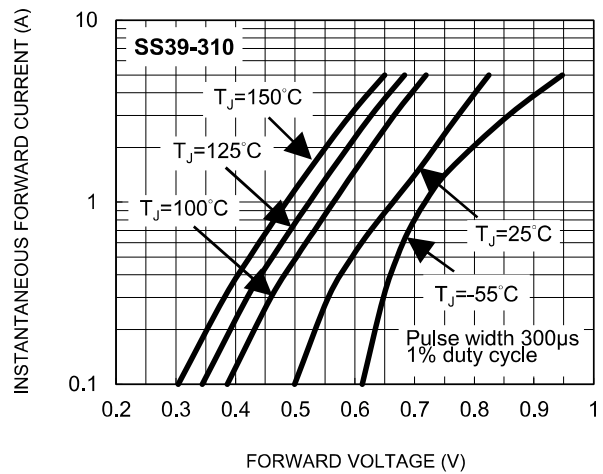

Fig.9 Typical Reverse Characteristics

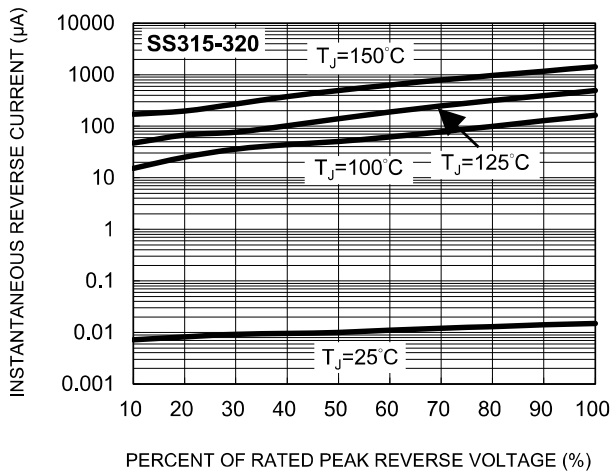

Fig.10 Typical Forward Characteristics

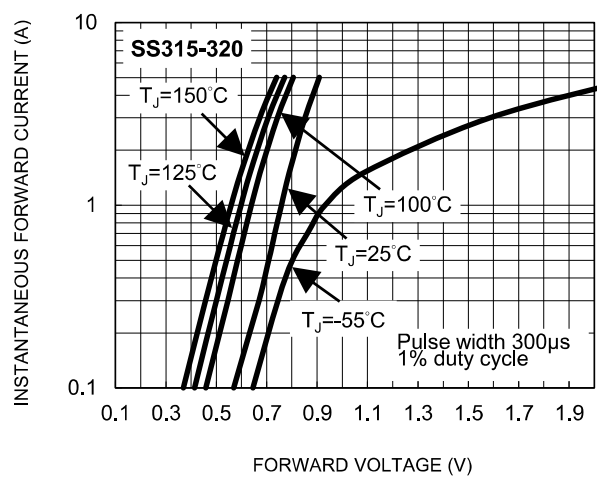

Fig.11 Typical Forward Power Dissipation vs. Forward Current

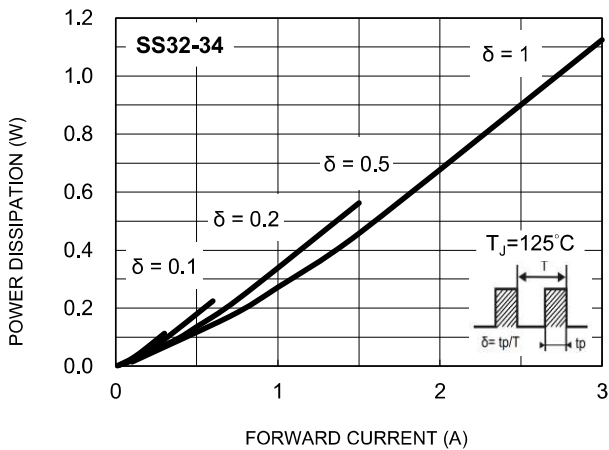
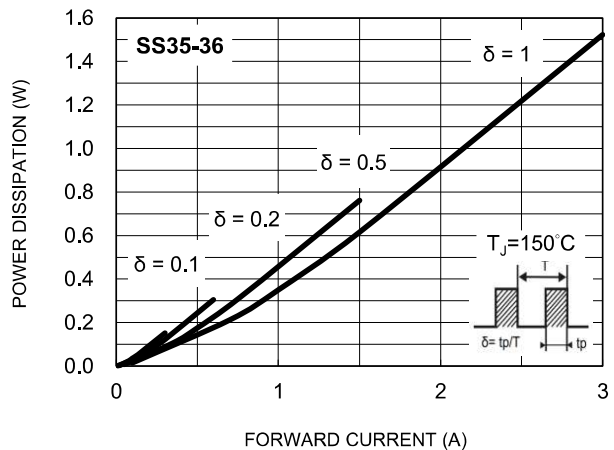

Fig.12 Typical Forward Power Dissipation vs. Forward Current



CHARACTERISTICS CURVES

($T_A = 25^\circ\text{C}$ unless otherwise noted)

Fig.13 Typical Forward Power Dissipation vs. Forward Current

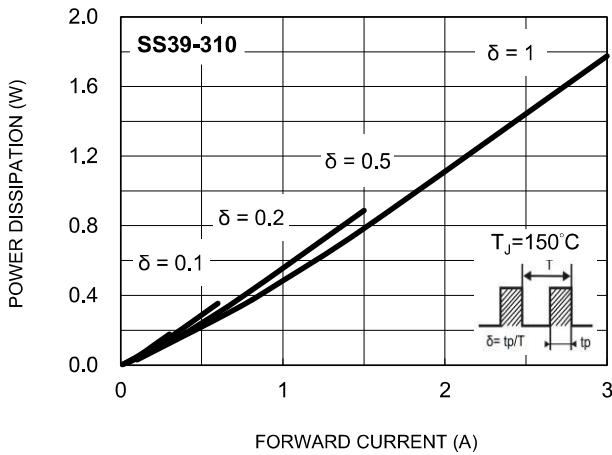

Fig.14 Typical Forward Power Dissipation vs. Forward Current

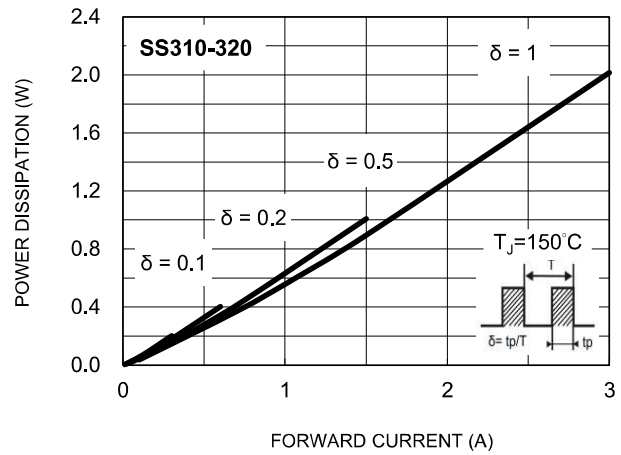

Fig.15 Maximum Non-Repetitive Forward Surge Current

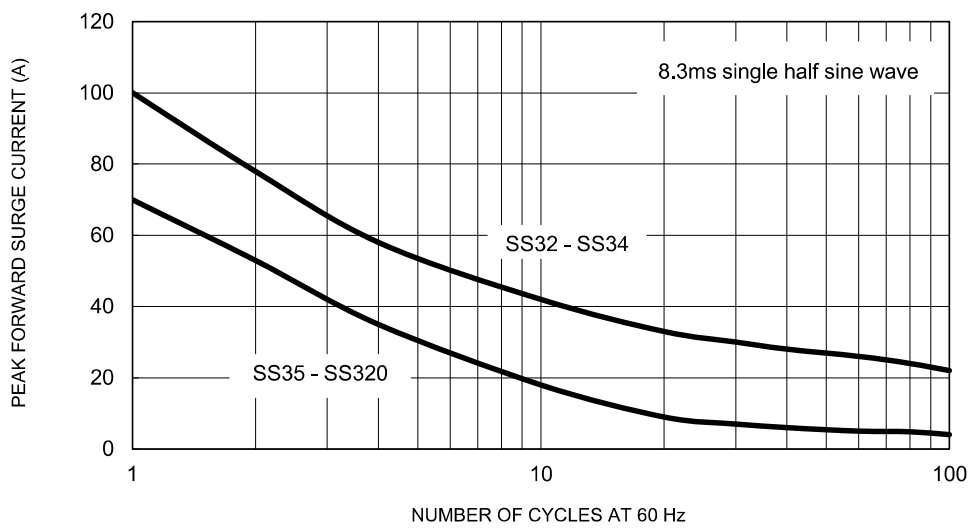
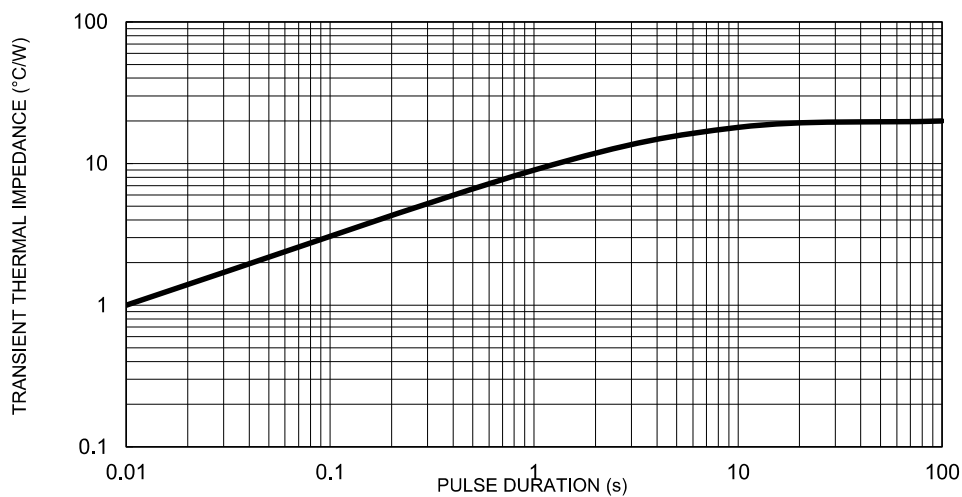
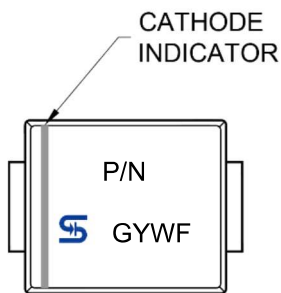
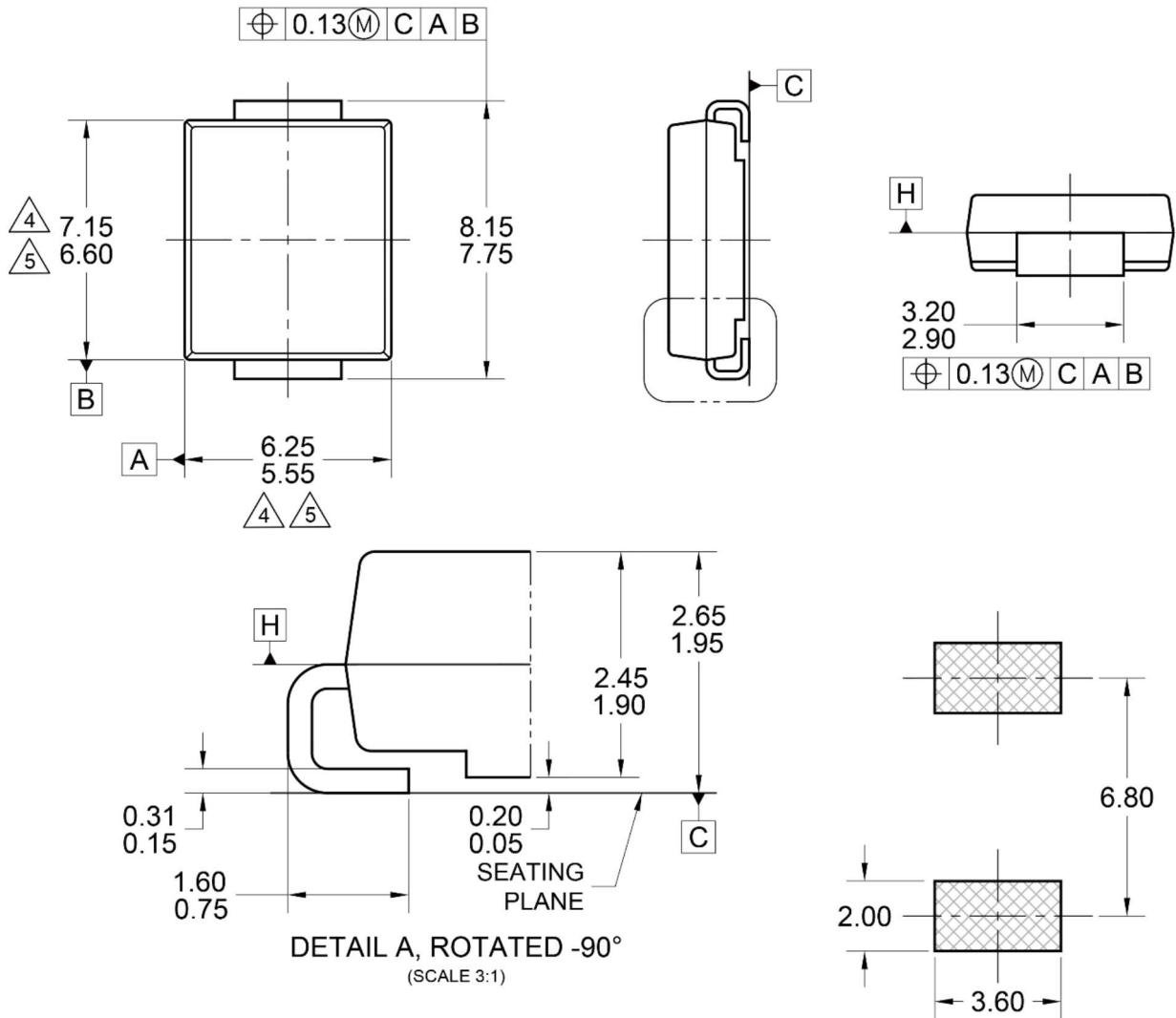

Fig.16 Typical Transient Thermal Characteristics



PACKAGE OUTLINE DIMENSIONS

DO-214AB (SMC)



MARKING DIAGRAM

P/N = Device marking
G = Green compound
YW = Date code
F = Factory code

SUGGESTED PAD LAYOUT

NOTES: UNLESS OTHERWISE SPECIFIED

1. ALL DIMENSIONS ARE IN MILLIMETERS.
2. DIMENSIONING AND TOLERANCING PER ASME Y14.5M-1994.
3. PACKAGE OUTLINE REFERENCE: JEDEC DO-214, VARIATION AB, ISSUE D.
4. MOLDED PLASTIC BODY DIMENSIONS DO NOT INCLUDE MOLD FLASH.
5. MOLDED PLASTIC BODY LATERAL DIMENSIONS TO BE DETERMINED AT DATUM PLANE H.
6. DWG NO. REF: HQ2SD07-DO214SMC-036 REV A.

Notice

Specifications of the products displayed herein are subject to change without notice. TSC or anyone on its behalf assumes no responsibility or liability for any errors or inaccuracies.

Purchasers are solely responsible for the choice, selection, and use of TSC products and TSC assumes no liability for application assistance or the design of Purchasers' products.

Information contained herein is intended to provide a product description only. No license, express or implied, to any intellectual property rights is granted by this document. Except as provided in TSC's terms and conditions of sale for such products, TSC assumes no liability whatsoever, and disclaims any express or implied warranty, relating to sale and/or use of TSC products including liability or warranties relating to fitness for a particular purpose, merchantability, or infringement of any patent, copyright, or other intellectual property right.

The products shown herein are not designed for use in medical, life-saving, or life-sustaining applications. Customers using or selling these products for use in such applications do so at their own risk and agree to fully indemnify TSC for any damages resulting from such improper use or sale.