

INA1x9 High-Side Measurement Current Shunt Monitor

1 Features

- Complete Unipolar High-Side Current Measurement Circuit
- Wide Supply and Common-Mode Range
- INA139: 2.7 V to 40 V
- INA169: 2.7 V to 60 V
- Independent Supply and Input Common-Mode Voltages
- Single Resistor Gain Set
- Low Quiescent Current: 60 μ A (Typical)
- 5-Pin, SOT-23 Packages

2 Applications

- Current Shunt Measurement:
 - Automotive, Telephone, Computers
- Portable and Battery-Backup Systems
- Battery Chargers
- Power Management
- Cell Phones
- Precision Current Source

3 Description

The INA139 and INA169 are high-side, unipolar, current shunt monitors. Wide input common-mode voltage range, high-speed, low quiescent current, and tiny SOT-23 packaging enable use in a variety of applications.

Input common-mode and power-supply voltages are independent and can range from 2.7 V to 40 V for the INA139 and 2.7 V to 60 V for the INA169. Quiescent current is only 60 μ A, which permits connecting the power supply to either side of the current measurement shunt with minimal error.

The device converts a differential input voltage to a current output. This current is converted back to a voltage with an external load resistor that sets any gain from 1 to over 100. Although designed for current shunt measurement, the circuit invites creative applications in measurement and level shifting.

Both the INA139 and INA169 are available in 5-pin SOT-23 packages. The INA139 device is specified for the -40°C to $+125^{\circ}\text{C}$ temperature range, and the INA169 is specified from -40°C to $+85^{\circ}\text{C}$.

Device Information⁽¹⁾

PART NUMBER	PACKAGE	BODY SIZE (NOM)
INA139	SOT-23 (5)	2.90 mm \times 1.60 mm
INA169		

(1) For all available packages, see the orderable addendum at the end of the data sheet.

Typical Application Circuit

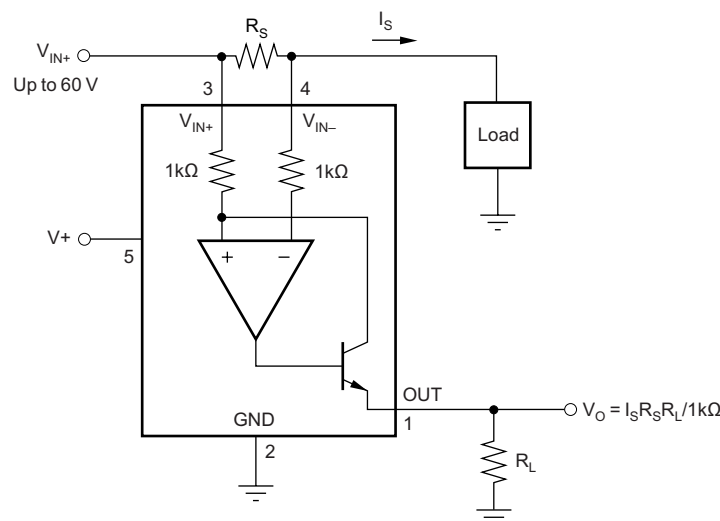

Copyright © 2017, Texas Instruments Incorporated



Table of Contents

1 Features	1	7.4 Device Functional Modes.....	10
2 Applications	1	8 Application and Implementation	11
3 Description	1	8.1 Application Information.....	11
4 Revision History	2	8.2 Typical Applications	12
5 Pin Configuration and Functions	3	9 Power Supply Recommendations	18
6 Specifications	4	10 Layout	19
6.1 Absolute Maximum Ratings	4	10.1 Layout Guidelines	19
6.2 ESD Ratings	4	10.2 Layout Example	19
6.3 Recommended Operating Conditions.....	4	11 Device and Documentation Support	20
6.4 Thermal Information	5	11.1 Related Links	20
6.5 Electrical Characteristics.....	6	11.2 Community Resources.....	20
6.6 Typical Characteristics.....	7	11.3 Trademarks	20
7 Detailed Description	9	11.4 Electrostatic Discharge Caution.....	20
7.1 Overview	9	11.5 Glossary	20
7.2 Functional Block Diagram	9	12 Mechanical, Packaging, and Orderable Information	20
7.3 Feature Description.....	9		

4 Revision History

NOTE: Page numbers for previous revisions may differ from page numbers in the current version.

Changes from Revision E (December 2015) to Revision F	Page
• Changed INA139 maximum temperature specification from +85°C to +125°C in <i>Description</i> section	1
• Changed INA139 device maximum temperature specification from +85°C to +125°C in <i>Description</i> section	1
• Updated <i>Typical Application Circuit</i> graphic on front page with 2017 copyright	1
• Updated pinout diagram in <i>Pin Configurations and Functions</i> section	3
• Reformatted <i>Recommended Operating Conditions</i> table	4
• Changed common-mode rejection minimum value from 100 dB to 99 dB in the <i>Electrical Characteristics</i> table	6
• Changed offset voltage maximum value from ± 1 mV to ± 1.5 mV in the <i>Electrical Characteristics</i> table.....	6
• Changed INA139 nonlinearity error maximum value from $\pm 0.1\%$ to $\pm 0.13\%$ in the <i>Electrical Characteristics</i> table	6
• Changed maximum value of INA139 temperature range specification from 85°C to 125°C in the <i>Electrical Characteristics</i> table	6
• Added updated copyright statement to <i>Functional Block Diagram</i>	9

Changes from Revision D (November 2005) to Revision E	Page
• Changed <i>ESD Ratings</i> table, <i>Feature Description</i> section, <i>Device Functional Modes</i> , <i>Application and Implementation</i> section, <i>Power Supply Recommendations</i> section, <i>Layout</i> section, <i>Device and Documentation Support</i> section, and <i>Mechanical, Packaging, and Orderable Information</i> section	1

5 Pin Configuration and Functions

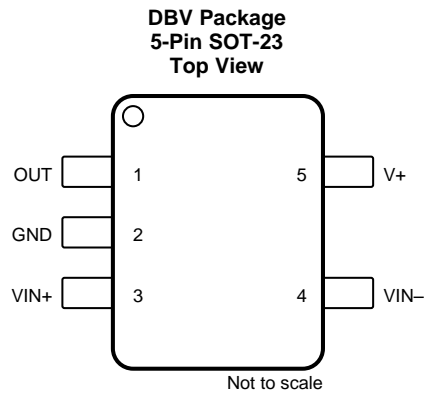

Pin Functions

PIN		I/O	DESCRIPTION
NAME	NO.		
GND	2	—	Ground
OUT	1	O	Output current
VIN+	3	I	Positive input voltage
VIN-	4	I	Negative input voltage
V+	5	I	Power supply voltage

6 Specifications

6.1 Absolute Maximum Ratings

over operating free-air temperature range (unless otherwise noted)⁽¹⁾

		MIN	MAX	UNIT
Supply voltage, V_S	INA139	-0.3	60	V
	INA169	-0.3	75	V
Analog inputs, INA139	Common-mode ⁽²⁾	-0.3	60	V
	Differential (V_{IN+}) – (V_{IN-})	-40	2	V
Analog inputs, INA169	Common-mode ⁽²⁾	-0.3	75	V
	Differential (V_{IN+}) – (V_{IN-})	-40	2	V
Analog input, out ⁽²⁾		-0.3	40	V
Input current into any pin			10	mA
Operating temperature, T_A		-55	125	°C
Junction temperature, T_J			150	°C
Storage temperature, T_{stg}		-65	125	°C

- (1) Stresses beyond those listed under *Absolute Maximum Ratings* may cause permanent damage to the device. These are stress ratings only, which do not imply functional operation of the device at these or any other conditions beyond those indicated under *Recommended Operating Conditions*. Exposure to absolute-maximum-rated conditions for extended periods may affect device reliability.
- (2) The input voltage at any pin may exceed the voltage shown if the current at that pin is limited to 10 mA.

6.2 ESD Ratings

		VALUE	UNIT
$V_{(ESD)}$ Electrostatic discharge	Human-body model (HBM), per ANSI/ESDA/JEDEC JS-001 ⁽¹⁾	±1000	V
	Charged-device model (CDM), per JEDEC specification JESD22-C101 ⁽²⁾	±500	

- (1) JEDEC document JEP155 states that 500-V HBM allows safe manufacturing with a standard ESD control process.
- (2) JEDEC document JEP157 states that 250-V CDM allows safe manufacturing with a standard ESD control process.

6.3 Recommended Operating Conditions

over operating free-air temperature range (unless otherwise noted)

		MIN	NOM	MAX	UNIT	
V+	Power-supply voltage	INA139	2.7	5	40	V
		INA169	2.7	5	60	
	Common-mode voltage	INA139	2.7	12	40	V
		INA169	2.7	12	60	

6.4 Thermal Information

THERMAL METRIC ⁽¹⁾		INA1x9	UNIT
		DBV (SOT-23)	
		5 PINS	
$R_{\theta JA}$	Junction-to-ambient thermal resistance	168.3	°C/W
$R_{\theta JC(top)}$	Junction-to-case (top) thermal resistance	73.8	°C/W
$R_{\theta JB}$	Junction-to-board thermal resistance	28.1	°C/W
Ψ_{JT}	Junction-to-top characterization parameter	2.5	°C/W
Ψ_{JB}	Junction-to-board characterization parameter	27.6	°C/W

(1) For more information about traditional and new thermal metrics, see the [Semiconductor and IC Package Thermal Metrics](#) application report.

6.5 Electrical Characteristics

INA139: all other characteristics at $T_A = -40^\circ\text{C}$ to $+125^\circ\text{C}$, $V_+ = 5\text{ V}$, $V_{IN+} = 12\text{ V}$, and $R_{OUT} = 25\text{ k}\Omega$, unless otherwise noted

INA169: all other characteristics at $T_A = -40^\circ\text{C}$ to $+85^\circ\text{C}$, $V_+ = 5\text{ V}$, $V_{IN+} = 12\text{ V}$, and $R_{OUT} = 25\text{ k}\Omega$, unless otherwise noted

PARAMETER	TEST CONDITIONS	MIN	TYP	MAX	UNIT
INPUT					
Full-scale sense voltage	$V_{SENSE} = V_{IN+} - V_{IN-}$		100	500	mV
Common-mode input range	INA139	2.7		40	V
	INA169	2.7		60	
Common-mode rejection	INA139: $V_{IN+} = 2.7\text{ V to }40\text{ V}$, $V_{SENSE} = 50\text{ mV}$	99	115		dB
	INA169: $V_{IN+} = 2.7\text{ V to }60\text{ V}$, $V_{SENSE} = 50\text{ mV}$	100	120		dB
Offset voltage ⁽¹⁾ RTI	INA139		± 0.2	± 1.5	mV
	INA169		± 0.2	± 1	
vs. temperature	T_{MIN} to T_{MAX}		1		$\mu\text{V}/^\circ\text{C}$
vs power supply (V_+)	INA139: $V_+ = 2.7\text{ V to }40\text{ V}$, $V_{SENSE} = 50\text{ mV}$		0.5	10	$\mu\text{V}/\text{V}$
	INA169: $V_+ = 2.7\text{ V to }60\text{ V}$, $V_{SENSE} = 50\text{ mV}$		0.1	10	$\mu\text{V}/\text{V}$
Input bias current			10		μA
OUTPUT					
Transconductance vs temperature	$V_{SENSE} = 10\text{ mV} - 150\text{ mV}$	990	1000	1010	$\mu\text{A}/\text{V}$
	$V_{SENSE} = 10\text{ mV}$		10		$\text{nA}/^\circ\text{C}$
Nonlinearity error	$V_{SENSE} = 10\text{ mV to }150\text{ mV}$	INA139	$\pm 0.01\%$	$\pm 0.13\%$	
		INA169	$\pm 0.01\%$	$\pm 0.1\%$	
Total output error	$V_{SENSE} = 100\text{ mV}$		$\pm 0.5\%$	$\pm 2\%$	
Output impedance			$1 \parallel 5$		$\text{G}\Omega \parallel \text{pF}$
Voltage output	Swing to power supply, V_+		$(V_+) - 0.9$	$(V_+) - 1.2$	V
	Swing to common-mode, V_{CM}		$V_{CM} - 0.6$	$V_{CM} - 1$	
FREQUENCY RESPONSE					
Bandwidth	$R_{OUT} = 10\text{ k}\Omega$		440		kHz
	$R_{OUT} = 20\text{ k}\Omega$		220		kHz
Settling time (0.1%)	5-V step, $R_{OUT} = 10\text{ k}\Omega$		2.5		μs
	5-V step, $R_{OUT} = 20\text{ k}\Omega$		5		μs
NOISE					
Output-current noise density			20		$\text{pA}/\sqrt{\text{Hz}}$
Total output-current noise	$\text{BW} = 100\text{ kHz}$		7		nA RMS
POWER SUPPLY					
Operating range, V_+	INA139	2.7		40	V
	INA169	2.7		60	V
Quiescent current	$V_{SENSE} = 0$, $I_O = 0$		60	125	μA
TEMPERATURE RANGE					
Specification, T_{MIN} to T_{MAX}	INA139	-40		125	$^\circ\text{C}$
	INA169	-40		85	$^\circ\text{C}$
Operating		-55		125	$^\circ\text{C}$
Storage		-65		150	$^\circ\text{C}$
Thermal resistance, θ_{JA}			200		$^\circ\text{C}/\text{W}$

(1) Defined as the amount of voltage (V_{SENSE}) to drive the output to zero.

6.6 Typical Characteristics

at $T_A = 25^\circ\text{C}$, $V_+ = 5\text{ V}$, $V_{IN+} = 12\text{ V}$, and $R_L = 125\text{ k}\Omega$, unless otherwise noted.

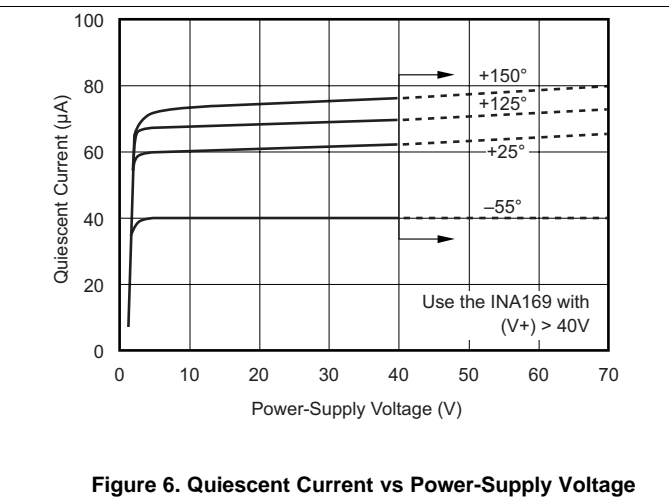
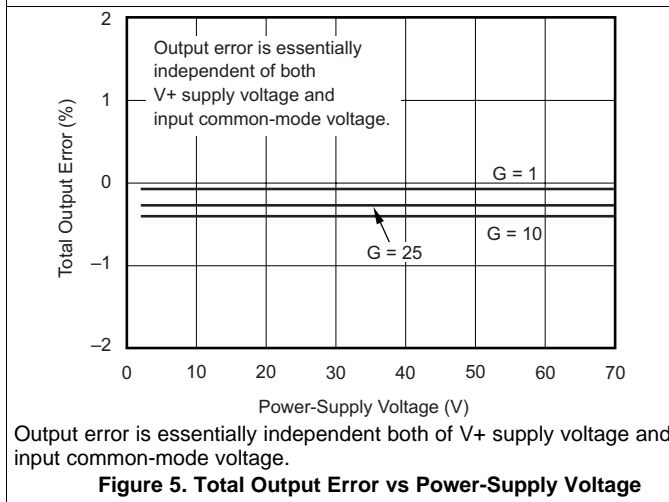
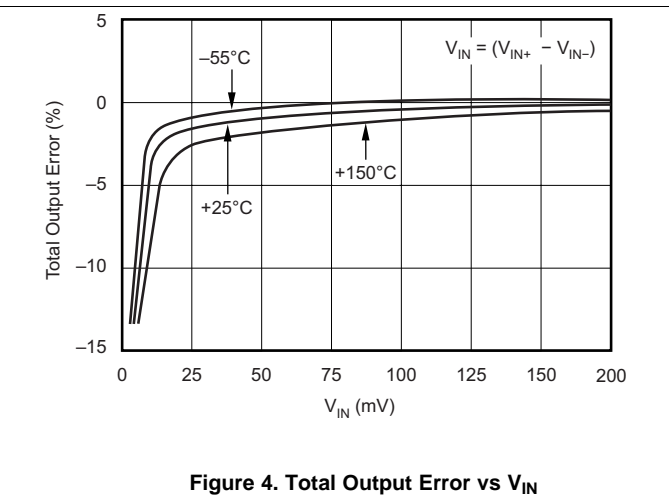
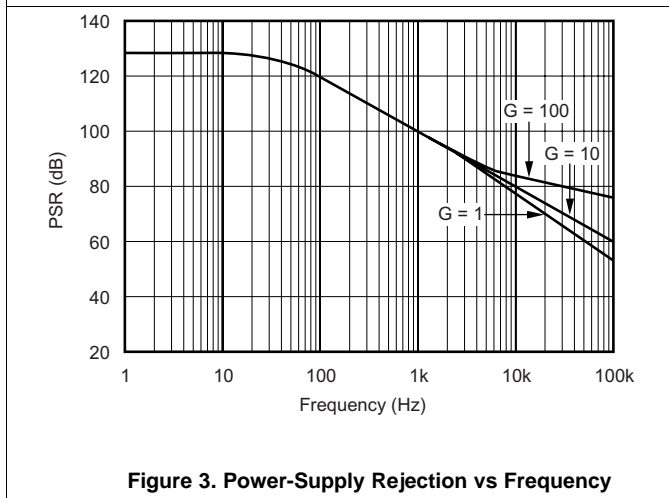
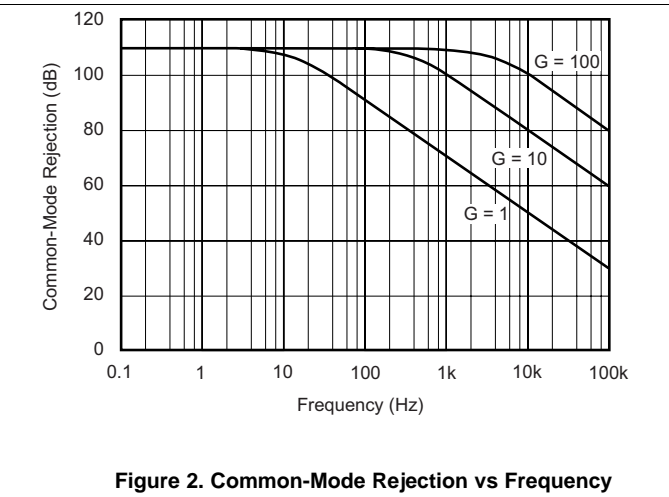
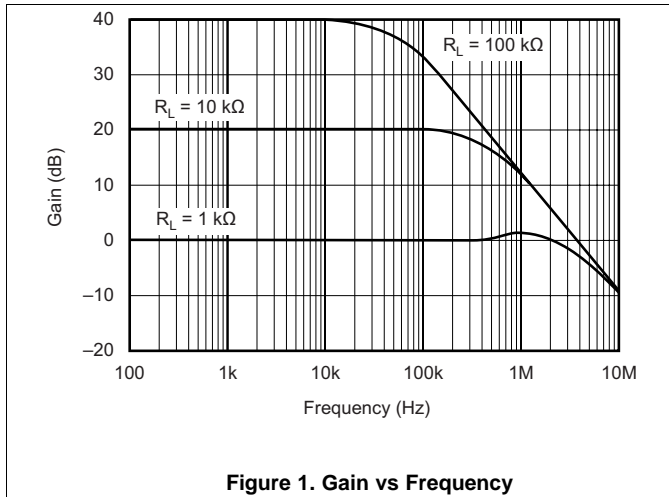

Typical Characteristics (continued)

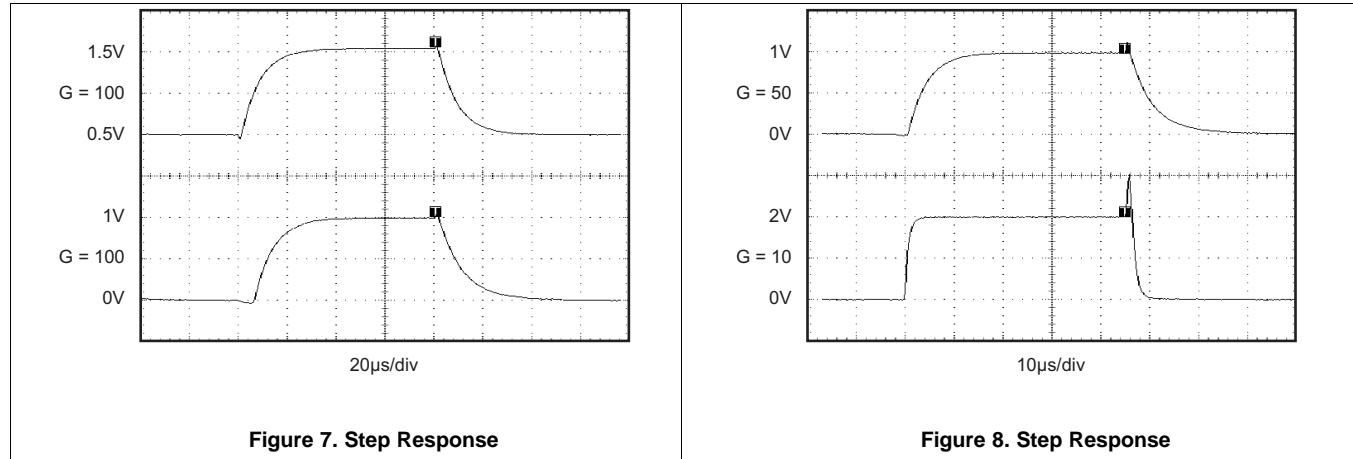
 at $T_A = 25^\circ\text{C}$, $V_+ = 5\text{ V}$, $V_{IN+} = 12\text{ V}$, and $R_L = 125\text{ k}\Omega$, unless otherwise noted.

7 Detailed Description

7.1 Overview

The INA139 and INA169 devices are comprised of a high voltage, precision operational amplifier, precision thin film resistors trimmed in production to an absolute tolerance and a low noise output transistor. The INA139 and INA169 devices can be powered from a single power supply and their input voltages can exceed the power supply voltage. The INA139 and INA169 devices are ideal for measuring small differential voltages, such as those generated across a shunt resistor in the presence of large, common-mode voltages. See the [Functional Block Diagram](#), which illustrates the functional components within both the INA139 and INA169 devices.

7.2 Functional Block Diagram

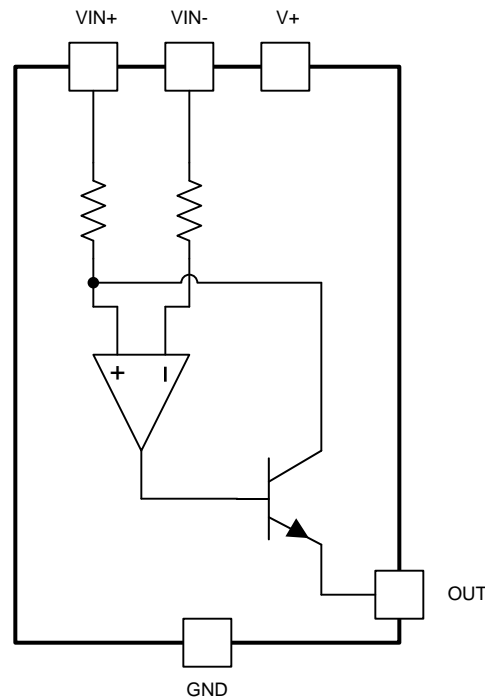

Copyright © 2017, Texas Instruments Incorporated

7.3 Feature Description

7.3.1 Output Voltage Range

The output of the INA139 is a current, which is converted to a voltage by the load resistor (R_L). The output current remains accurate within the *compliance voltage range* of the output circuitry. The shunt voltage and the input common-mode and power-supply voltages limit the maximum possible output swing. The maximum output voltage compliance is limited by the lower of [Equation 1](#) and [Equation 2](#).

$$V_{OUTMAX} = (V+) - 0.7\text{ V} - (V_{IN+} - V_{IN-}) \quad (1)$$

or whichever is lower

$$V_{OUTMAX} = V_{IN-} - 0.5\text{ V} \quad (2)$$

Feature Description (continued)

7.3.2 Bandwidth

Measurement bandwidth is affected by the value of the load resistor (R_L). High gain produced by high values of R_L yield a narrower measurement bandwidth (see the [Typical Characteristics](#) graphs). For widest possible bandwidth, keep the capacitive load on the output to a minimum. Reduction in bandwidth due to capacitive load is shown in the [Typical Characteristics](#) graphs.

If bandwidth limiting (filtering) is desired, a capacitor can be added to the output (see [Figure 12](#)). This does not cause instability.

7.4 Device Functional Modes

For proper operation the INA139 and INA169 devices must operate within their specified limits. Operating either device outside of their specified power supply voltage range or their specified common-mode range results in unexpected behavior and is not recommended. Additionally operating the output beyond their specified limits with respect to power supply voltage and input common-mode voltage will also produce unexpected results. See the [Electrical Characteristics](#) table for device specifications.

8 Application and Implementation

NOTE

Information in the following applications sections is not part of the TI component specification, and TI does not warrant its accuracy or completeness. TI's customers are responsible for determining suitability of components for their purposes. Customers should validate and test their design implementation to confirm system functionality.

8.1 Application Information

8.1.1 Operation

[Figure 9](#) illustrates the basic circuit diagram for both the INA139 and INA169. Load current I_S is drawn from supply V_S through shunt resistor R_S . The voltage drop in shunt resistor V_S is forced across R_{G1} by the internal operational amplifier, causing current to flow into the collector of Q1. The external resistor R_L converts the output current to a voltage, V_{OUT} , at the OUT pin.

The transfer function for the INA139 is given by [Equation 3](#):

$$I_O = g_m (V_{IN+} - V_{IN-})$$

where

- $g_m = 1000 \mu A/V$ (3)

In the circuit of [Figure 9](#), the input voltage ($V_{IN+} - V_{IN-}$) is equal to $I_S \times R_S$ and the output voltage (V_{OUT}) is equal to $I_O \times R_L$. The transconductance (g_m) of the INA139 is $1000 \mu A/V$. The complete transfer function for the current measurement amplifier in this application is given by [Equation 4](#):

$$V_{OUT} = (I_S)(R_S)(1000 \mu A / V)(R_L) \tag{4}$$

The maximum differential input voltage for accurate measurements is 0.5 V, which produces a 500- μA output current. A differential input voltage of up to 2 V will not cause damage. Differential measurements (pins 3 and 4) must be unipolar with a more-positive voltage applied to pin 3. If a more-negative voltage is applied to pin 3, the output current, I_O , is zero, but it will not cause damage.

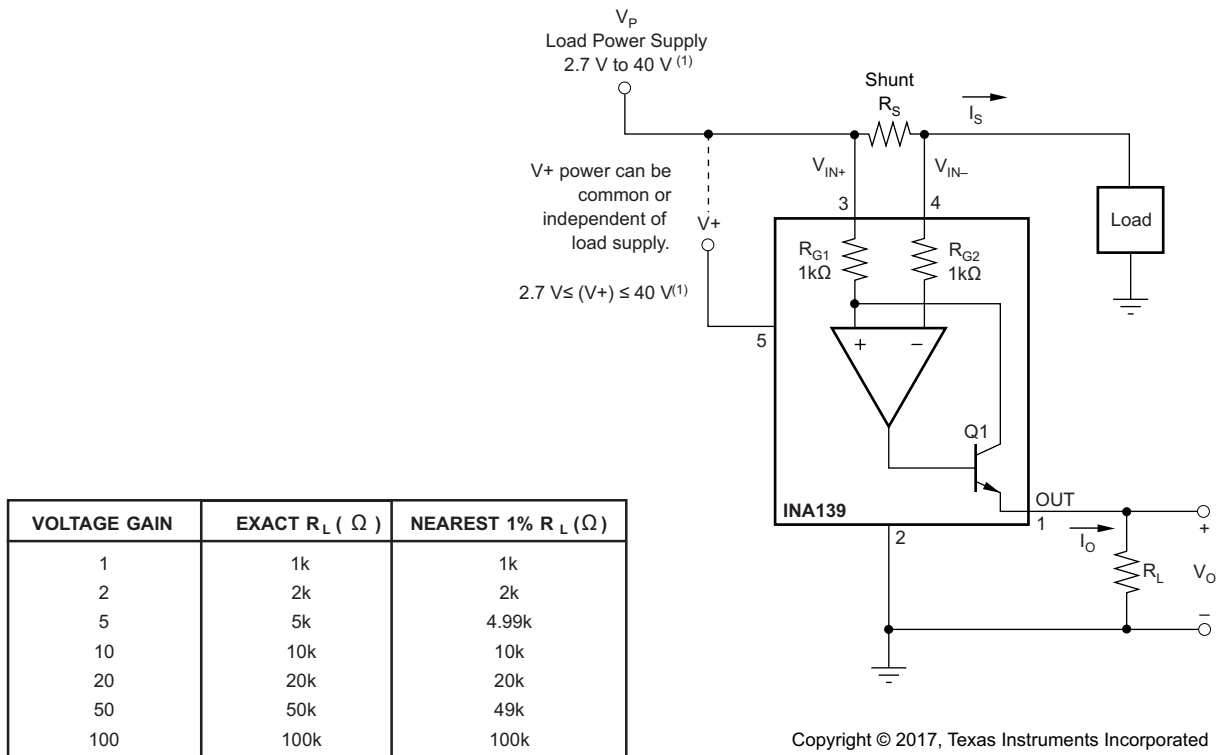
Application Information (continued)

(1) For the INA169 device, maximum V_P and V_+ voltage is 60 V.

Figure 9. Basic Circuit Connections
8.2 Typical Applications

The INA139 is designed for current shunt measurement circuits, as shown in [Figure 9](#), but its basic function is useful in a wide range of circuitry. A creative engineer will find many unforeseen uses in measurement and level shifting circuits. A few ideas are illustrated in [Figure 14](#) through [Figure 18](#).

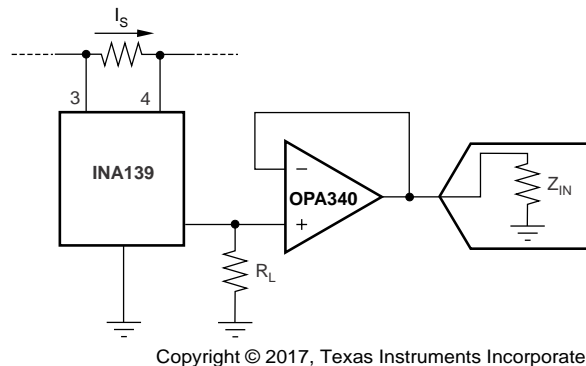
8.2.1 Buffering Output to Drive an ADC

(1) Buffer of amp drives the A/D converter without effecting gain

Figure 10. Buffering Output to Drive the A/D Converter
8.2.1.1 Design Requirements

Digitize the output of the INA139 or INA169 devices using a 1-MSPS analog-to-digital converter (ADC).

Typical Applications (continued)

8.2.1.2 Detailed Design Procedure

8.2.1.2.1 Selecting R_S and R_L

In [Figure 9](#) the value selected for the shunt resistor (R_S) depends on the application and is a compromise between small-signal accuracy and maximum permissible voltage loss in the measurement line. High values of R_S provide better accuracy at lower currents by minimizing the effects of offset, while low values of R_S minimize voltage loss in the supply line. For most applications, best performance is attained with an R_S value that provides a full-scale shunt voltage of 50 mV to 100 mV; maximum input voltage for accurate measurements is 500 mV.

R_L is selected to provide the desired full-scale output voltage. The output impedance of the INA139 and INA169 OUT terminal is very high, which permits using values of R_L up to 100 k Ω with excellent accuracy. The input impedance of any additional circuitry at the output must be much higher than the value of R_L to avoid degrading accuracy.

Some analog-to-digital converters (ADCs) have input impedances that significantly affect measurement gain. The input impedance of the ADC can be included as part of the effective R_L if the input can be modeled as a resistor to ground. Alternatively, an operational amplifier can be used to buffer the ADC input, as shown in [Figure 10](#). The INA139 and INA169 are current output devices, and have an inherently large output impedance. The output currents from the amplifier are converted to an output voltage through the load resistor (R_L) connected from the amplifier output to ground. The ratio of the load resistor value to that of the internal resistor value determines the voltage gain of the system.

In many applications, digitizing the output of the INA139 or INA169 devices is required. This is accomplished by connecting the output of the amplifier to an ADC. It is very common for an ADC to have a dynamic input impedance. If the INA139 or INA169 output is connected directly to an ADC input, the input impedance of the ADC is effectively connected in parallel with the gain setting resistor (R_L .) This parallel impedance combination affects the gain of the system and the impact on the gain is difficult to estimate accurately. A simple solution that eliminates the paralleling of impedances, simplifying the gain of the circuit is to place a buffer amplifier (such as the [OPA340](#)) between the output of the INA139 or INA169 devices and the input to the ADC.

[Figure 10](#) illustrates this concept. A low-pass filter can be placed between the [OPA340](#) output and the input to the ADC. The filter capacitor is required to provide any instantaneous demand for current required by the input stage of the ADC. The filter resistor is required to isolate the [OPA340](#) output from the filter capacitor to maintain circuit stability. The values for the filter components vary according to the operational amplifier used for the buffer and the particular ADC selected. For more information regarding the design of the low-pass filter, see the [16-bit 1-MSPS Data Acquisition Reference Design for Single-Ended Multiplexed Applications](#) TI Precision Design.

[Figure 11](#) shows the expected results when driving an analog-to-digital converter at 1 MSPS with and without buffering the INA139 or INA169 output. Without the buffer, the high impedance of the INA139 or INA169 reacts with the input capacitance and sample and hold (S/H) capacitance of the analog-to-digital converter and does not allow the S/H to reach the correct final value before the S/H resets and the next conversion starts. Adding the buffer amplifier significantly reduces the output impedance driving the S/H and allows for higher conversion rates than can be achieved without adding the buffer.

Typical Applications (continued)

8.2.1.3 Application Curve

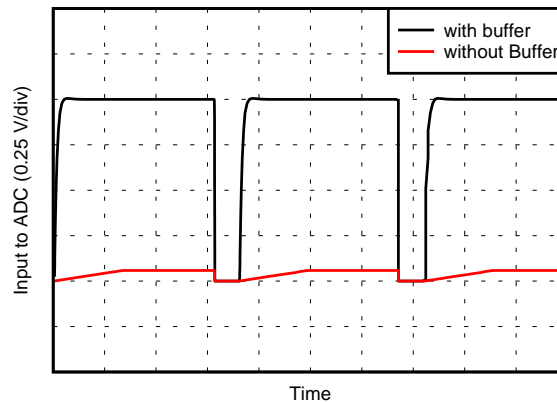
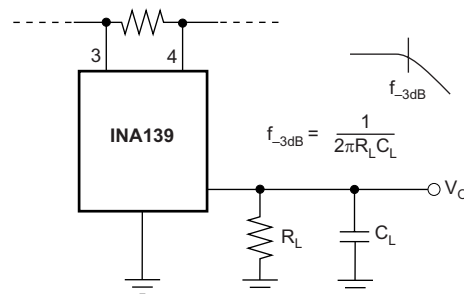

Figure 11. Driving an ADC With and Without a Buffer

8.2.2 Output Filter



Copyright © 2017, Texas Instruments Incorporated

Figure 12. Output Filter

8.2.2.1 Design Requirements

Filter the output of the INA139 or INA169 devices.

8.2.2.2 Detailed Design Procedure

A low-pass filter can be formed at the output of the INA139 or INA169 devices simply by placing a capacitor of the desired value in parallel with the load resistor. First, determine the value of the load resistor required to achieve the desired gain. See the table in [Figure 9](#). Next, determine the capacitor value that results in the desired cutoff frequency according to the equation shown in [Figure 12](#). [Figure 13](#) illustrates various combinations of gain settings (determined by R_L) and filter capacitors.

Typical Applications (continued)

8.2.2.3 Application Curve

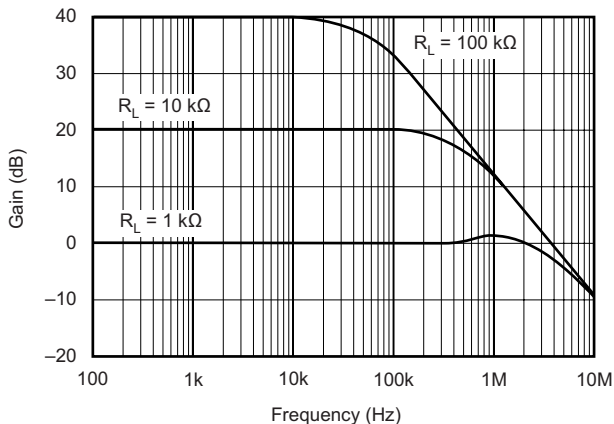
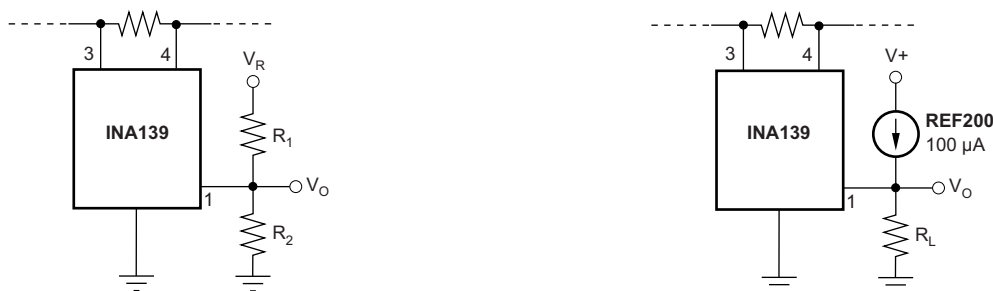

Figure 13. Gain vs Frequency

8.2.3 Offsetting the Output Voltage

For many applications using only a single power supply, it may be required to level shift the output voltage away from ground when there is no load current flowing in the shunt resistor. Level shifting the output of the INA139 or INA169 devices is easily accomplished by one of two simple methods shown in Figure 14. The method on the left hand side of Figure 14 illustrates a simple voltage divider method. This method is useful for applications that require the output of the INA139 or INA169 devices to remain centered with respect to the power supply at zero load current through the shunt resistor. Using this method the gain is determined by the parallel combination of R_1 and R_2 , while the output offset is determined by the voltage divider ratio R_1 and R_2 . For applications that may require a fixed value of output offset independent of the power supply voltage, TI recommends using the current source method shown on the right hand side of Figure 14. With this method, a REF200 constant current source is used to generate a constant output offset. Using this method, the gain is determined by R_L and the offset is determined by the product of the value of the current source and R_L .



Copyright © 2017, Texas Instruments Incorporated

- (1) Gain set by $R_1 \parallel R_2$. Output offset = $(V_R) R_2 / (R_1 + R_2)$ using resistor divider.
- (2) Gain set by R_L . Output offset = $100 \mu A \times R_L$ (independent of $V+$) using current source.

Figure 14. Offsetting the Output Voltage

Typical Applications (continued)

8.2.4 Bipolar Current Measurement

The INA139 or INA169 devices can be configured as shown in Figure 15 in applications where measuring current bi-directionally is required. Two INA devices are required connecting their inputs across the shunt resistor as shown in Figure 15. A comparator, such as the TLV3201, is used to detect the polarity of the load current. The magnitude of the load current is monitored across the resistor connected between ground and the connection labeled *Output*. In this example the 20-kΩ resistor results in a gain of 20 V/V. The 10-kΩ resistors connected in series with the INA139 or INA169 output current are used to develop a voltage across the comparator inputs. Two diodes are required to prevent current flow into the INA139 or INA169 output, as only one device at a time is providing current to the *Output* connection of the circuit. The circuit functionality is illustrated in Figure 16.

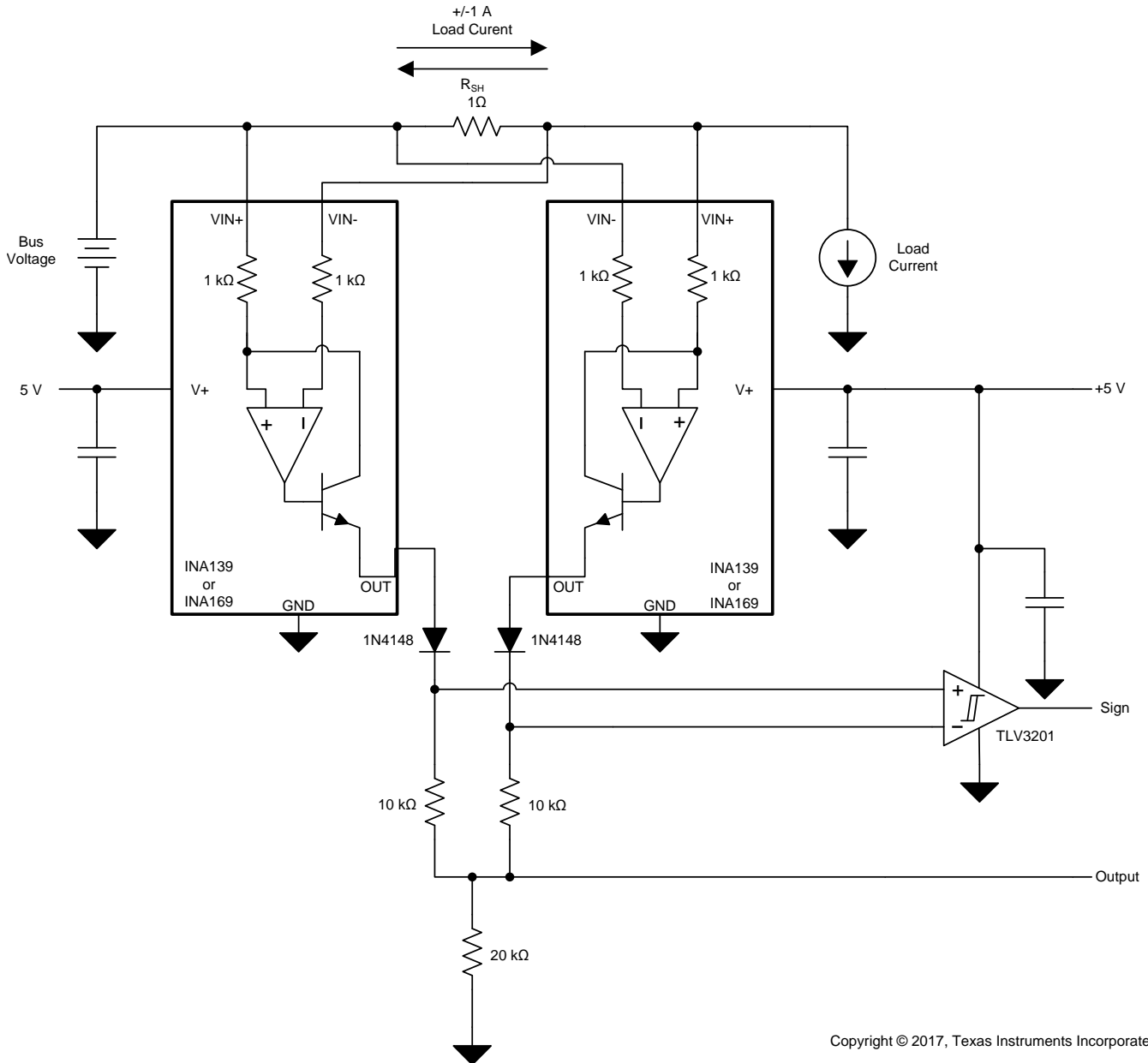

Copyright © 2017, Texas Instruments Incorporated

Figure 15. Bipolar Current Measurement

Typical Applications (continued)

8.2.4.1 Application Curve

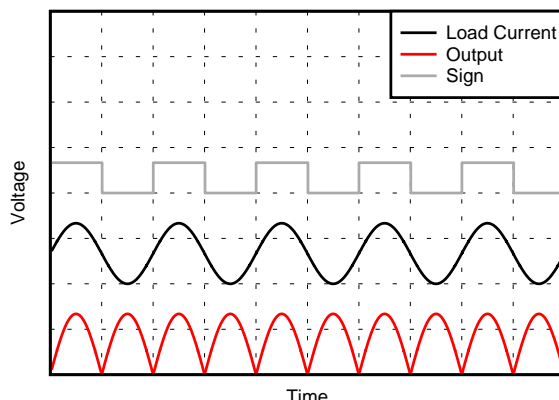
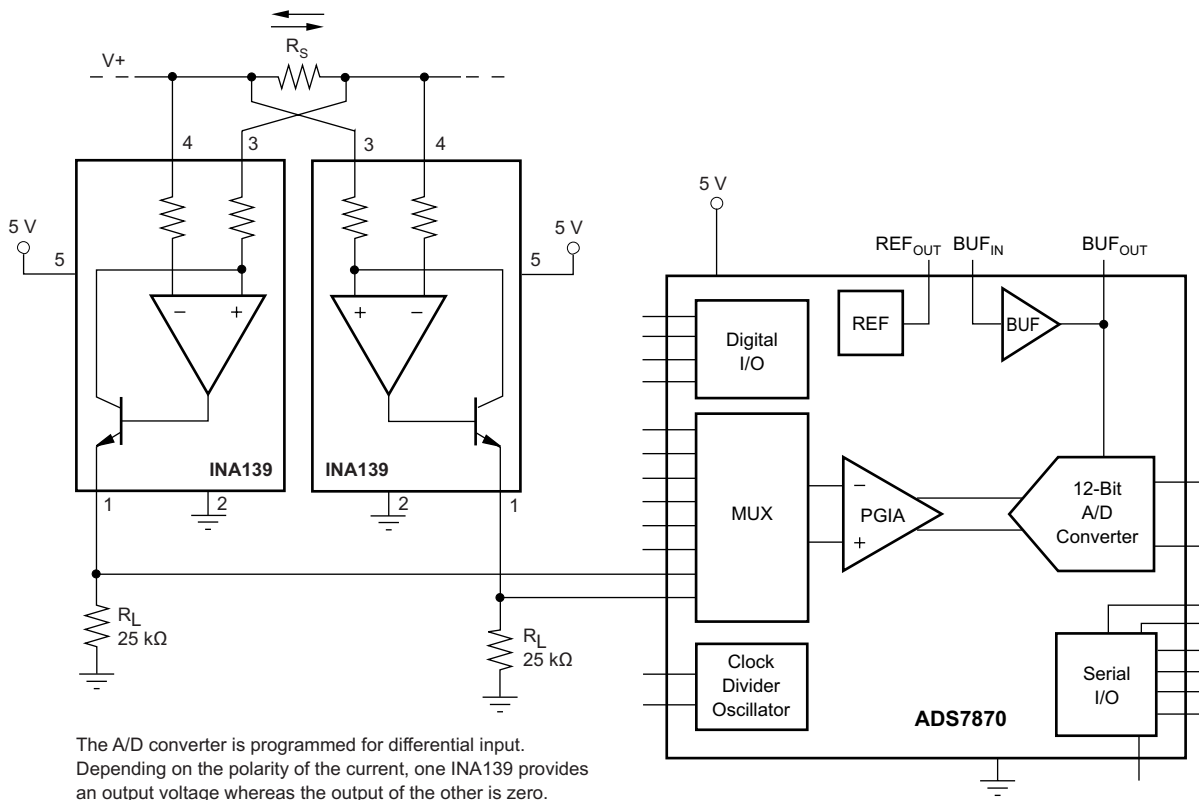

Figure 16. Bipolar Current Measurement Results (Arbitrary Scale)

8.2.5 Bipolar Current Measurement Using a Differential Input of the A/D Converter

The INA139 or INA169 devices can be used with an ADC such as the [ADS7870](#) programmed for differential mode operation. Figure 17 illustrates this configuration. In this configuration, the use of two devices allows for bidirectional current measurement. Depending upon the polarity of the current, one of the devices provides an output voltage while the other output is zero. In this way, the ADC reads the polarity of current directly, without requiring additional circuitry.



Copyright © 2017, Texas Instruments Incorporated

Figure 17. Bipolar Current Measurement Using a Differential Input of the A/D Converter

Typical Applications (continued)

8.2.6 Multiplexed Measurement Using Logic Signal for Power

Multiple loads can be measured as illustrated in [Figure 18](#). In this configuration, each INA139 or INA169 device is powered by the digital I/O from the [ADS7870](#). Multiplex each device by switching the desired I/O on or off.

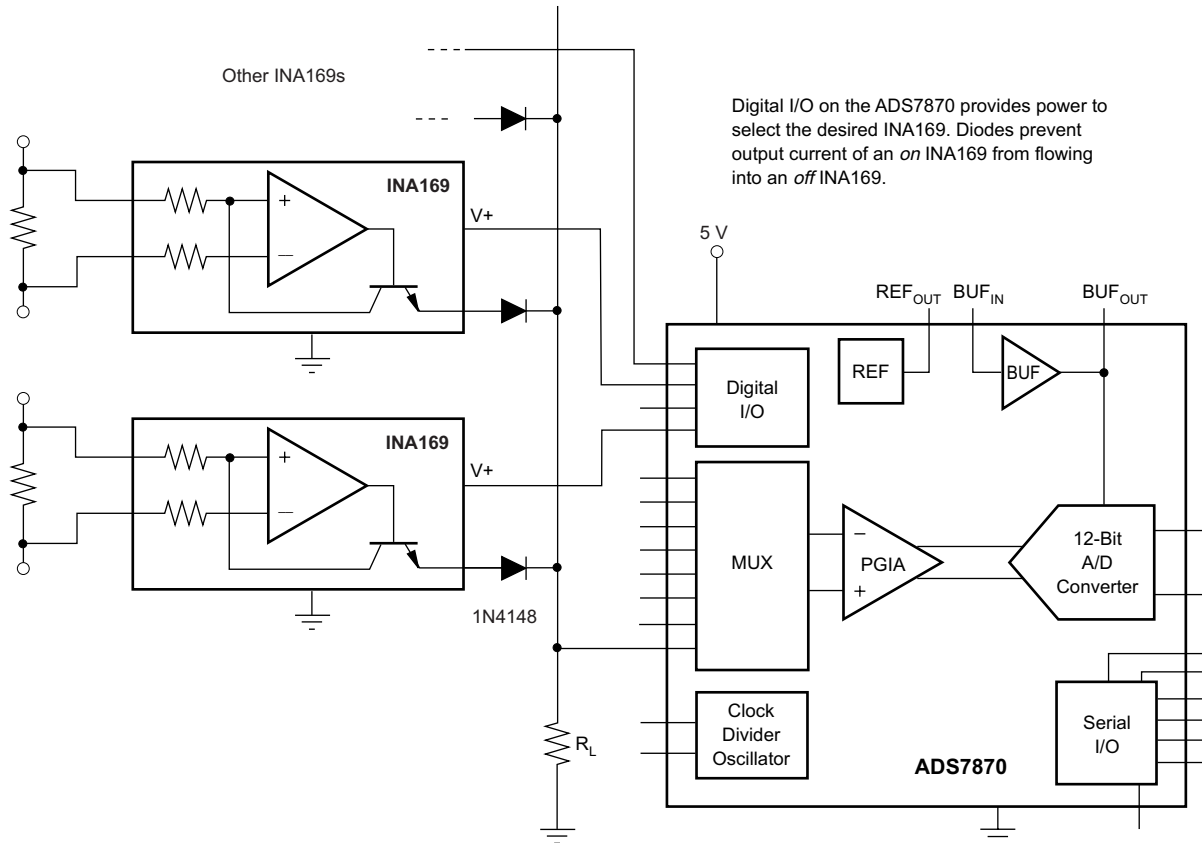

Copyright © 2017, Texas Instruments Incorporated

Figure 18. Multiplexed Measurement Using Logic Signal for Power

9 Power Supply Recommendations

The input circuitry of the INA139 can accurately measure beyond the power-supply voltage ($V+$). For example, the $V+$ power supply can be 5 V, whereas the load power supply voltage is up to 40 V (or 60 V with the INA169). However, the output voltage range of the OUT terminal is limited by the lesser of the two voltages (see the [Output Voltage Range](#) section). TI recommends placing a 0.1- μ F capacitor near the $V+$ pin on the INA139 or INA169. Additional capacitance may be required for applications with noisy supply voltages.

10 Layout

10.1 Layout Guidelines

Figure 19 shows the basic connection of the INA139. The input pins (V_{IN+} and V_{IN-}) must be connected as closely as possible to the shunt resistor to minimize any resistance in series with the shunt resistance. The output resistor, R_L , is shown connected between pin 1 and ground. Best accuracy is achieved with the output voltage measured directly across R_L . This is especially important in high-current systems where load current could flow in the ground connections, affecting the measurement accuracy.

No power-supply bypass capacitors are required for stability of the INA139. However, applications with noisy or high-impedance power supplies may require decoupling capacitors to reject power-supply noise; connect the bypass capacitors close to the device pins.

10.2 Layout Example

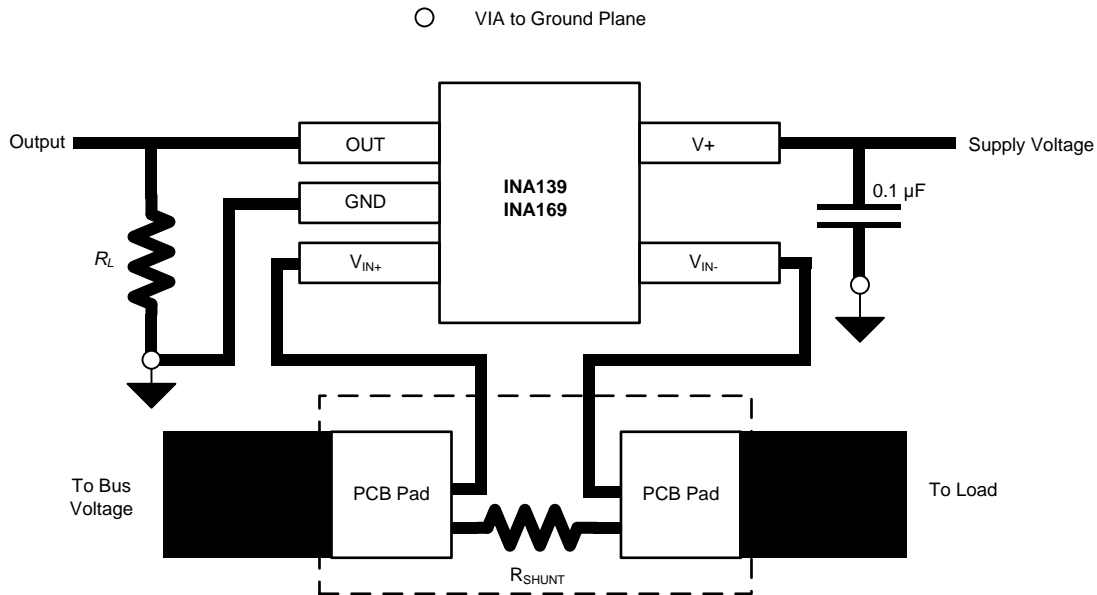

Copyright © 2017, Texas Instruments Incorporated

Figure 19. Typical Layout Example

11 Device and Documentation Support

11.1 Related Links

The table below lists quick access links. Categories include technical documents, support and community resources, tools and software, and quick access to sample or buy.

Table 1. Related Links

PARTS	PRODUCT FOLDER	ORDER NOW	TECHNICAL DOCUMENTS	TOOLS & SOFTWARE	SUPPORT & COMMUNITY
INA139	Click here	Click here	Click here	Click here	Click here
INA169	Click here	Click here	Click here	Click here	Click here

11.2 Community Resources

The following links connect to TI community resources. Linked contents are provided "AS IS" by the respective contributors. They do not constitute TI specifications and do not necessarily reflect TI's views; see TI's [Terms of Use](#).

TI E2E™ Online Community *TI's Engineer-to-Engineer (E2E) Community*. Created to foster collaboration among engineers. At e2e.ti.com, you can ask questions, share knowledge, explore ideas and help solve problems with fellow engineers.

Design Support *TI's Design Support* Quickly find helpful E2E forums along with design support tools and contact information for technical support.

11.3 Trademarks

E2E is a trademark of Texas Instruments.
All other trademarks are the property of their respective owners.

11.4 Electrostatic Discharge Caution



These devices have limited built-in ESD protection. The leads should be shorted together or the device placed in conductive foam during storage or handling to prevent electrostatic damage to the MOS gates.

11.5 Glossary

SLYZ022 — *TI Glossary*.

This glossary lists and explains terms, acronyms, and definitions.

12 Mechanical, Packaging, and Orderable Information

The following pages include mechanical, packaging, and orderable information. This information is the most current data available for the designated devices. This data is subject to change without notice and revision of this document. For browser-based versions of this data sheet, refer to the left-hand navigation.

PACKAGING INFORMATION

Orderable part number	Status (1)	Material type (2)	Package Pins	Package qty Carrier	RoHS (3)	Lead finish/ Ball material (4)	MSL rating/ Peak reflow (5)	Op temp (°C)	Part marking (6)
INA139NA/250	Active	Production	SOT-23 (DBV) 5	250 SMALL T&R	Yes	NIPDAU	Level-2-260C-1 YEAR	-40 to 125	E39
INA139NA/250.A	Active	Production	SOT-23 (DBV) 5	250 SMALL T&R	Yes	NIPDAU	Level-2-260C-1 YEAR	-40 to 125	E39
INA139NA/3K	Active	Production	SOT-23 (DBV) 5	3000 LARGE T&R	Yes	NIPDAU	Level-2-260C-1 YEAR	-40 to 125	E39
INA139NA/3K.A	Active	Production	SOT-23 (DBV) 5	3000 LARGE T&R	Yes	NIPDAU	Level-2-260C-1 YEAR	-40 to 125	E39
INA169NA/250	Active	Production	SOT-23 (DBV) 5	250 SMALL T&R	Yes	NIPDAU	Level-2-260C-1 YEAR	-40 to 125	A69
INA169NA/250.A	Active	Production	SOT-23 (DBV) 5	250 SMALL T&R	Yes	NIPDAU	Level-2-260C-1 YEAR	-40 to 125	A69
INA169NA/3K	Active	Production	SOT-23 (DBV) 5	3000 LARGE T&R	Yes	NIPDAU	Level-2-260C-1 YEAR	-40 to 125	A69
INA169NA/3K.A	Active	Production	SOT-23 (DBV) 5	3000 LARGE T&R	Yes	NIPDAU	Level-2-260C-1 YEAR	-40 to 125	A69

(1) **Status:** For more details on status, see our [product life cycle](#).

(2) **Material type:** When designated, preproduction parts are prototypes/experimental devices, and are not yet approved or released for full production. Testing and final process, including without limitation quality assurance, reliability performance testing, and/or process qualification, may not yet be complete, and this item is subject to further changes or possible discontinuation. If available for ordering, purchases will be subject to an additional waiver at checkout, and are intended for early internal evaluation purposes only. These items are sold without warranties of any kind.

(3) **RoHS values:** Yes, No, RoHS Exempt. See the [TI RoHS Statement](#) for additional information and value definition.

(4) **Lead finish/Ball material:** Parts may have multiple material finish options. Finish options are separated by a vertical ruled line. Lead finish/Ball material values may wrap to two lines if the finish value exceeds the maximum column width.

(5) **MSL rating/Peak reflow:** The moisture sensitivity level ratings and peak solder (reflow) temperatures. In the event that a part has multiple moisture sensitivity ratings, only the lowest level per JEDEC standards is shown. Refer to the shipping label for the actual reflow temperature that will be used to mount the part to the printed circuit board.

(6) **Part marking:** There may be an additional marking, which relates to the logo, the lot trace code information, or the environmental category of the part.

Multiple part markings will be inside parentheses. Only one part marking contained in parentheses and separated by a "~" will appear on a part. If a line is indented then it is a continuation of the previous line and the two combined represent the entire part marking for that device.

Important Information and Disclaimer: The information provided on this page represents TI's knowledge and belief as of the date that it is provided. TI bases its knowledge and belief on information provided by third parties, and makes no representation or warranty as to the accuracy of such information. Efforts are underway to better integrate information from third parties. TI has taken and continues to take reasonable steps to provide representative and accurate information but may not have conducted destructive testing or chemical analysis on incoming materials and chemicals. TI and TI suppliers consider certain information to be proprietary, and thus CAS numbers and other limited information may not be available for release.

In no event shall TI's liability arising out of such information exceed the total purchase price of the TI part(s) at issue in this document sold by TI to Customer on an annual basis.

OTHER QUALIFIED VERSIONS OF INA139, INA169 :

- Automotive : [INA139-Q1](#), [INA169-Q1](#)

NOTE: Qualified Version Definitions:

- Automotive - Q100 devices qualified for high-reliability automotive applications targeting zero defects

TAPE AND REEL INFORMATION

QUADRANT ASSIGNMENTS FOR PIN 1 ORIENTATION IN TAPE

*All dimensions are nominal

Device	Package Type	Package Drawing	Pins	SPQ	Reel Diameter (mm)	Reel Width W1 (mm)	A0 (mm)	B0 (mm)	K0 (mm)	P1 (mm)	W (mm)	Pin1 Quadrant
INA139NA/250	SOT-23	DBV	5	250	178.0	9.0	3.3	3.2	1.4	4.0	8.0	Q3
INA139NA/3K	SOT-23	DBV	5	3000	178.0	9.0	3.3	3.2	1.4	4.0	8.0	Q3
INA169NA/250	SOT-23	DBV	5	250	178.0	9.0	3.3	3.2	1.4	4.0	8.0	Q3
INA169NA/3K	SOT-23	DBV	5	3000	178.0	9.0	3.3	3.2	1.4	4.0	8.0	Q3

TAPE AND REEL BOX DIMENSIONS



*All dimensions are nominal

Device	Package Type	Package Drawing	Pins	SPQ	Length (mm)	Width (mm)	Height (mm)
INA139NA/250	SOT-23	DBV	5	250	180.0	180.0	18.0
INA139NA/3K	SOT-23	DBV	5	3000	180.0	180.0	18.0
INA169NA/250	SOT-23	DBV	5	250	180.0	180.0	18.0
INA169NA/3K	SOT-23	DBV	5	3000	180.0	180.0	18.0

EXAMPLE BOARD LAYOUT

DBV0005A

SOT-23 - 1.45 mm max height

SMALL OUTLINE TRANSISTOR



LAND PATTERN EXAMPLE
EXPOSED METAL SHOWN
SCALE:15X



SOLDER MASK DETAILS

4214839/K 08/2024

NOTES: (continued)

- 6. Publication IPC-7351 may have alternate designs.
- 7. Solder mask tolerances between and around signal pads can vary based on board fabrication site.

EXAMPLE STENCIL DESIGN

DBV0005A

SOT-23 - 1.45 mm max height

SMALL OUTLINE TRANSISTOR



SOLDER PASTE EXAMPLE
BASED ON 0.125 mm THICK STENCIL
SCALE:15X

4214839/K 08/2024

NOTES: (continued)

8. Laser cutting apertures with trapezoidal walls and rounded corners may offer better paste release. IPC-7525 may have alternate design recommendations.
9. Board assembly site may have different recommendations for stencil design.

IMPORTANT NOTICE AND DISCLAIMER

TI PROVIDES TECHNICAL AND RELIABILITY DATA (INCLUDING DATASHEETS), DESIGN RESOURCES (INCLUDING REFERENCE DESIGNS), APPLICATION OR OTHER DESIGN ADVICE, WEB TOOLS, SAFETY INFORMATION, AND OTHER RESOURCES "AS IS" AND WITH ALL FAULTS, AND DISCLAIMS ALL WARRANTIES, EXPRESS AND IMPLIED, INCLUDING WITHOUT LIMITATION ANY IMPLIED WARRANTIES OF MERCHANTABILITY, FITNESS FOR A PARTICULAR PURPOSE OR NON-INFRINGEMENT OF THIRD PARTY INTELLECTUAL PROPERTY RIGHTS.

These resources are intended for skilled developers designing with TI products. You are solely responsible for (1) selecting the appropriate TI products for your application, (2) designing, validating and testing your application, and (3) ensuring your application meets applicable standards, and any other safety, security, regulatory or other requirements.

These resources are subject to change without notice. TI grants you permission to use these resources only for development of an application that uses the TI products described in the resource. Other reproduction and display of these resources is prohibited. No license is granted to any other TI intellectual property right or to any third party intellectual property right. TI disclaims responsibility for, and you fully indemnify TI and its representatives against any claims, damages, costs, losses, and liabilities arising out of your use of these resources.

TI's products are provided subject to [TI's Terms of Sale](#), [TI's General Quality Guidelines](#), or other applicable terms available either on [ti.com](#) or provided in conjunction with such TI products. TI's provision of these resources does not expand or otherwise alter TI's applicable warranties or warranty disclaimers for TI products. Unless TI explicitly designates a product as custom or customer-specified, TI products are standard, catalog, general purpose devices.

TI objects to and rejects any additional or different terms you may propose.

Copyright © 2025, Texas Instruments Incorporated

Last updated 10/2025