

PRODUCT SPECIFICATION

Part Number	FFC2XXX	Rev	E2	Date	10/08/23		
Product Description	0.5mm Pitch ZIF FPC			Page	1		
Doc Number	0.5mm FFC Spec	Prepared	CC	Checked	VJ	Approved	YR

Top Entry

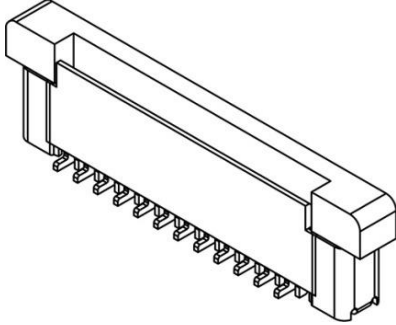

Side Entry
(Slide Actuator)

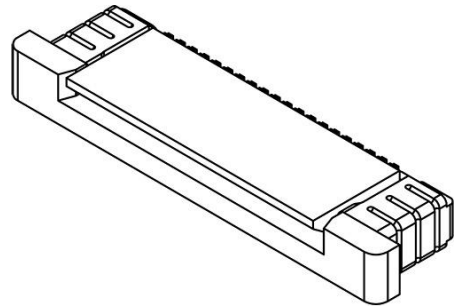

Side Entry
(Front Flip Type Actuator)

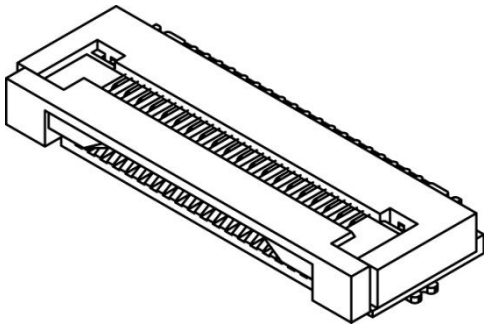

Side Entry
(Back Flip Type Actuator)

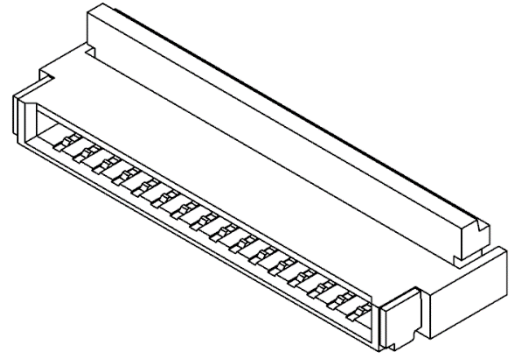

Side Entry
(Back Flip Type Actuator with Ear Lock)

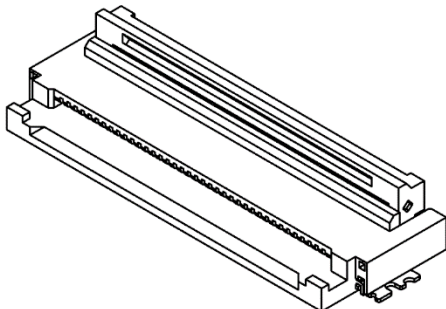

PRODUCT SPECIFICATION

Part Number	FFC2XXX	Rev	E2	Date	10/08/23		
Product Description	0.5mm Pitch ZIF FPC			Page	2		
Doc Number	0.5mm FFC Spec	Prepared	CC	Checked	VJ	Approved	YR

1.0 SCOPE

This specification covers performance, tests and quality requirements for 0.5mm Pitch ZIF FFC/FPC Connectors.

2.0 APPLICABLE DOCUMENTS

EIA-364 Electronics Industries Association

3.0 REQUIREMENTS

3.1 Design and Construction

Product shall be of design, construction and physical dimensions specified on applicable product drawing.

3.2 Materials and Finish

3.2.1 Housing: Specified on product drawing.

3.2.2 Actuator: Specified on product drawing.

3.2.3 Contact: High performance copper alloy (phosphor bronze)

Finish: (a) Finish: see ordering grid

(b) Under-plate: Nickel-plated all over

3.2.4 Fitting Nail: Brass, Tin-plated overall

3.3 Ratings

3.3.1 Voltage rating: Specified on product drawing

3.3.2 Current rating: Specified on product drawing

3.3.3 Operating Temperature Range: -25°C to +85°C or better.

PRODUCT SPECIFICATION

Part Number	FFC2XXX	Rev	E2	Date	10/08/23
Product Description	0.5mm Pitch ZIF FPC			Page	3
Doc Number	0.5mm FFC Spec	Prepared	CC	Checked	VJ
				Approved	YR

4.0 PERFORMANCE

Item	Test Condition	Requirement
Examination of Product	Visual, dimensional and functional per applicable quality inspection plan.	Product shall meet requirements of applicable product drawing and specification.

4.1 Electrical Performance

Item	Test Condition	Requirement
Low-signal Level Contact Resistance	Mate connectors, measure by dry circuit, 20mV Max., 100mA Max, in accordance with EIA-364-23.	As specified on product drawing
Insulation Resistance	Unmated connectors, apply 500 V DC between adjacent terminals, in accordance with EIA-364-21.	50 MΩ Min.
Dielectric Withstanding Voltage	Test between adjacent contacts of unmated connectors, in accordance with EIA-364-20.	250 VAC Min. at sea level for 1 minute. No discharge, flashover or breakdown. Current leakage: 0.5 mA max.
Temperature Rise	Mate connector: measure the temperature rise at rated current after: 0.5 A/Power contact. The temperature rise above ambient shall not exceed 30°C The ambient condition is still air at 25°C In accordance with EIA-364-70, Method 2.	30°C Max. Change allowed

4.2 Mechanical Performance

Item	Test Condition	Requirement
Durability	The sample should be mounted in the tester and fully mated and unmated the number of cycles specified at the rate of 10±3mm/min. In accordance with EIA-364-09.	20 Cycles Min.
FPC Retention Force	Insert the actuator, pull the FPC at the speed rate of 10±3 mm/min.	Refer to FPC withdrawal force Refer to paragraph 7

PRODUCT SPECIFICATION

Part Number	FFC2XXX	Rev	E2	Date	10/08/23		
Product Description	0.5mm Pitch ZIF FPC			Page	4		
Doc Number	0.5mm FFC Spec	Prepared	CC	Checked	VJ	Approved	YR

Item	Test Condition	Requirement
Repeated Actuator Insertion/Withdrawal	Insert and withdraw actuator up to 20 cycles at the speed rate of less than 10 cycles/minute.	Appearance: No Damage LLCR: As specified on product drawing
Terminal/Housing Retention Force	Apply axial pull out force at the speed rate of 10±3 mm/minute. On the terminal assembled in the housing.	0.15kgf Min.
Fitting Nail/Housing Retention Force	Apply axial pull out force at the speed rate of 10± 3 mm/minute. On the fitting nail assembled in the housing.	0.01kgf Min.
Vibration	The electrical load condition shall be 100 mA maximum for all contacts. Subject to a simple harmonic motion having amplitude of 0.76mm (1.52mm maximum total excursion) in frequency between the limits of 10 and 55 Hz. The entire frequency range, from 10 to 55 Hz and return to 10 Hz, shall be traversed in approximately 1 minute. This motion shall be applied for 2 hours in each of three mutually perpendicular directions. In accordance with EIA-364-28, Condition I.	Appearance: No Damage LLCR: 60 mΩ Max. Discontinuity: 1 u sec Max.
Shock (Mechanical)	Subject mated connectors to 50 G's (peak value) half-sine shock pulses of 11 milliseconds duration. Three shocks in each direction shall be applied along the three mutually perpendicular axes of the test specimen (18 shocks). The electrical load condition shall be 100mA maximum for all contacts. In accordance with EIA-364-27, test condition A.	Appearance: No Damage LLCR: 60 mΩ Max. Discontinuity: 1 u sec Max.

PRODUCT SPECIFICATION

Part Number	FFC2XXX	Rev	E2	Date	10/08/23		
Product Description	0.5mm Pitch ZIF FPC			Page	5		
Doc Number	0.5mm FFC Spec	Prepared	CC	Checked	VJ	Approved	YR

4.3 Environmental Performance

Item	Test Condition	Requirement
Resistance to Reflow Soldering Heat	Pre Heat: 150°C ~180°C, 60~90sec. Heat: 230°C Min., 40sec Min. Peak Temp.: 260°C Max, 10sec Max.	No Damage
Resistance to Hand Soldering Heat	Soldering iron: 350±10°C Duration: 3~4 sec.	No Damage
Thermal Shock	Mate module and subject to follow condition for 5 cycles. 1 cycles: -55 +0/-3 °C, 30 minutes +85 +3/-0 °C, 30 minutes In accordance with EIA-364-32, test condition I.	Appearance: No Damage LLCR: 60 mΩ Max.
Humidity	Mated Connector 40°C, 90~95% RH, Refer to Method II. In accordance with EIA-364-31, test condition A.	Appearance: No Damage LLCR: 60 mΩ Max. Insulation Resistance: 50MΩ Min. Dielectric Withstanding Voltage: No discharge, flashover or breakdown. Current leakage: 0.5 mA max.
Temperature Life	Subject mated connectors to temperature life at 85°C for 96 hours. Measure Signal. In accordance with EIA-364-17, test condition A.	Appearance: No Damage LLCR: 60 mΩ Max.
SO2 Gas	Mate applicable FPC and expose them to the following SO2 gas atmosphere. Temperature: 40±2°C Gas Density: 50±5 ppm Duration: 24 hours	Appearance: No Damage LLCR: 60 mΩ Max.
Salt Spray	Subject mated/unmated connectors to 5% salt-solution concentration, 35°C for 48 hours. In accordance with EIA-364-26, test condition B.	Appearance: No Damage LLCR: 60 mΩ Max.
Solderability	Subject the test area of contacts into the flux for 5-10 sec. And then into solder bath, Temperature at 245 ±5°C, for 4-5 sec. In accordance with EIA-364-52.	Solder able area shall have minimum of 95% solder coverage.
<div style="display: inline-block; border: 1px solid black; padding: 2px;">Halogen Free</div> 	Test report available on request	See product drawing

Note. Flowing Mixed Gas shall be conducted upon customer request, costs may apply.

PRODUCT SPECIFICATION

Part Number	FFC2XXX	Rev	E2	Date	10/08/23
Product Description	0.5mm Pitch ZIF FPC			Page	6
Doc Number	0.5mm FFC Spec	Prepared	CC	Checked	VJ
				Approved	YR

5.0 INFRA RED REFLOW CONDITION

5.1 Lead-Free Process: Duration = 2 times

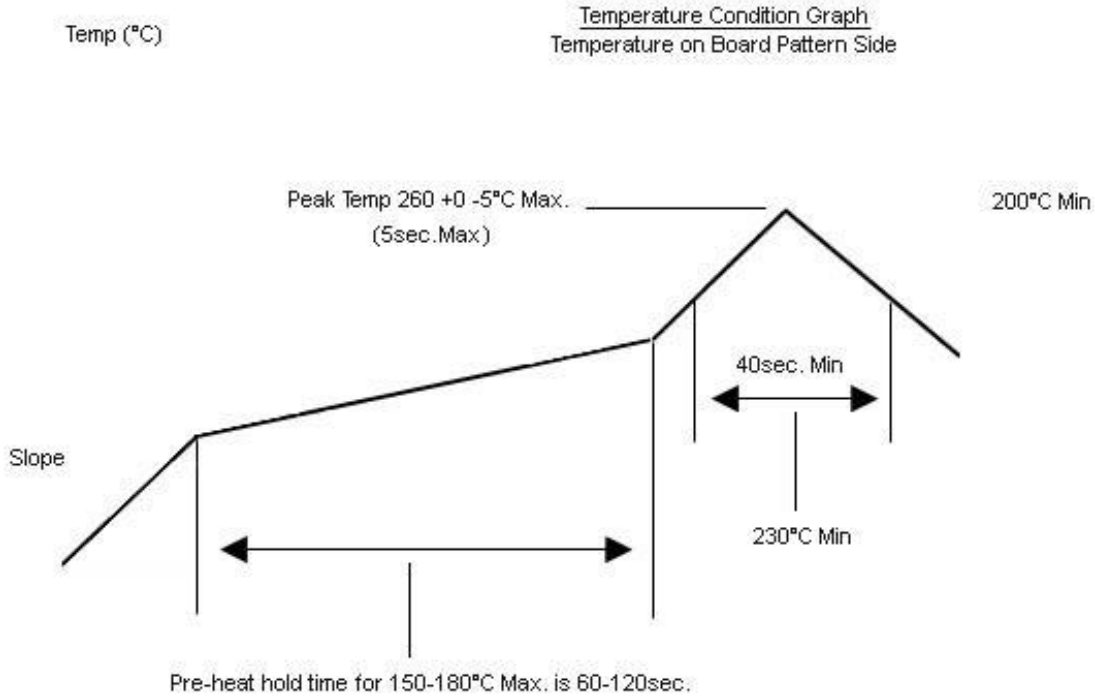

PRODUCT SPECIFICATION

Part Number	FFC2XXX	Rev	E2	Date	10/08/23		
Product Description	0.5mm Pitch ZIF FPC				Page	7	
Doc Number	0.5mm FFC Spec	Prepared	CC	Checked	VJ	Approved	YR

6.0 PRODUCT QUALIFICATION AND TEST SEQUENCE

Test or Examination	Test Group											
	1	2	3	4	5	6	7	8	9	10	11	12
	Test Sequence											
Examination of Product	1,3	1,7	1,6	1,5	1,9	1,5	1,3	1,4	1,3	1,6	1,3	1,3
Low-signal Level Contact Resistance		2,6	2,5	2,4	2,8	2,4		2,5				
Insulation Resistance					3,7							
Dielectric Withstanding Voltage					4,6							
Temperature Rise	2											
Durability		4										
Vibration			3									
Shock (Mechanical)			4									
Thermal Shock				3								
Humidity					5							
Temperature Life						3						
SO ₂ Gas							2					
Salt Spray								3				
Solderability									2			
Repeated Actuator Insertion/Withdrawal										2		
FPC Retention Force										3		
Terminal / Housing Retention Force										4		
Fitting Nail / Housing Retention Force										5		
Resistance to Soldering Heat											2	
Resistance to Hand Soldering Heat												2
Sample Size	2	5	5	5	5	5	5	5	5	5	5	5

PRODUCT SPECIFICATION

Part Number	FFC2XXX	Rev	E2	Date	10/08/23
Product Description	0.5mm Pitch ZIF FPC			Page	8
Doc Number	0.5mm FFC Spec	Prepared	CC	Checked	VJ
				Approved	YR

7.0 FPC WITHDRAWAL FORCE

No. Of Ckt.	Withdrawal Force (Min)	No. Of Ckt.	Withdrawal Force (Min)	
4	0.3Kgf	38	1.5Kgf	
5		39		
6		40		
7		41		
8		42		
9		43		
10	0.5Kgf	44		
11		45		
12		46		
13		47		
14		48		
15		49		
16		50		
17		51		
18		52		
19		53		
20	1.0Kgf	54		2.0Kgf
21		55		
22		56		
23		57		
24		58		
25		59		
26		60		
27		61		
28		62		
29		63		
30	64			
31	1.5Kgf	65		
32		66		
33		67		
34		68		
35				
36				
37				

PRODUCT SPECIFICATION

Part Number	FFC2XXX	Rev	E2	Date	10/08/23		
Product Description	0.5mm Pitch ZIF FPC			Page	9		
Doc Number	0.5mm FFC Spec	Prepared	CC	Checked	VJ	Approved	YR

Revision Details:

Revision	Information	Page	Release Date
A	Specification Released	-	16/06/2010
B	Leaded temperature profile removed	6	26/11/2015
C	Add back flip type & Change LLCR specification from 20mΩ max. to 40mΩ max.	1,2	10/09/2019
D	Add back flip with ear lock type & update FPC Retention Force	1,8	18/02/2020
E	Update wording in Requirements	2,3,5	09/09/2022
E1	Minor update to operating temperature range	2	26/04/2023
E2	Update thermal shock test condition and requirement	4	10/08/2023