

TO ;  
\_\_\_\_\_

## S P E C I F I C A T I O N S

Product Name      PHOTOCOUPLER

---

Model No.          PC400

---

【Business dealing name : PC400J00000F】  
(CHINA products)

These specifications contain 12 pages including the cover and appendix.  
This specification sheets and attached sheets shall be both side copy.  
After confirmation of the contents, please be sure to send back 1 copy of the  
Specifications with approving signature on each.  
If you have any objections, please contact us before issuing purchasing order.

Accepted by:

Sharp Corporation

By: \_\_\_\_\_

By: J. Kamiyoshi

Name: \_\_\_\_\_

Name: T. Kamiyoshi

Title: \_\_\_\_\_

Title: Senior Manager

Date: \_\_\_\_\_

Electronic Components and Devices Account Div.

Date: Dec, 8, 2020

By: \_\_\_\_\_

By: T. Hiramatsu

Name: \_\_\_\_\_

Sharp Fukuyama Semiconductor Co., Ltd.

Title: \_\_\_\_\_

Name: T. Hiramatsu

Date: \_\_\_\_\_

Title: Division Manager

Sensor Business Expanding Div.

Semiconductor Business Unit

Date: Dec, 8, 2020

Reviewed by: \_\_\_\_\_

Prepared by: \_\_\_\_\_

By: K. IwamotoBy: H. Takakura

Name: K. Iwamoto

Name: H. Takakura

Title: Senior Manager

Title: Associate Manager

Date: Dec, 8, 2020Date: Dec 8, 2020

1. These specification sheets include materials protected under copyright of Sharp Corporation ("Sharp").  
Please handle with great cares and do not reproduce or cause anyone to reproduce them without Sharp's consent.
2. When using this Sharp product, please observe the absolute maximum ratings, other conditions and instructions for use described in the specification sheets, as well as the precautions mentioned below.  
Sharp assumes no responsibility for any damages resulting from use of the product which does not comply with absolute maximum ratings, other conditions and instructions for use included in the specification sheets, and the precautions mentioned below.

(Precautions)

- (1) In making catalogue or instruction manual based on the specification sheets, please verify the validity of the catalogue or instruction manuals after assembling Sharp products in customer's products at the responsibility of customer.
- (2) This Sharp product is designed for use in the following application areas ;
  - Computers • OA equipment • Telecommunication equipment (Terminal) • Measuring equipment
  - Tooling machines • Audio visual equipment • Home appliancesIf the use of the Sharp product in the above application areas is for equipment listed in paragraphs (3) or (4), please be sure to observe the precautions given in those respective paragraphs.
- (3) Appropriate measures, such as fail-safe design and redundant design considering the safety design of the overall system and equipment, should be taken to ensure reliability and safety when Sharp product is used for equipment in responsibility of customer which demands high reliability and safety in function and precision, such as ;
  - Transportation control and safety equipment (aircraft, train, automobile etc.)
  - Traffic signals • Gas leakage sensor breakers • Rescue and security equipment
  - Other safety equipment
- (4) Sharp product is designed for consumer goods and controlled as consumer goods in production and quality.  
Please do not use this product for equipment which require extremely high reliability and safety in function and precision, such as ;
  - Space equipment • Telecommunication equipment (for trunk lines)
  - Nuclear power control equipment • Medical equipment
- (5) Please contact and consult with a Sharp sales representative if there are any question regarding interpretation of the above four paragraphs.

3. Disclaimer

The warranty period for Sharp product is one (1) year after shipment.  
During the period, if there are any products problem, Sharp will repair (if applicable), replace or refund.  
Except the above, both parties will discuss to cope with the problems.

The failed Sharp product after the above one (1) year period will be coped with by Sharp, provided that both parties shall discuss and determine on sharing responsibility based on the analysis results thereof subject to the above scope of warranty.

The warranty described herein is only for Sharp product itself which are purchased by or delivered to customer.  
Damages arising from Sharp product malfunction or failure shall be excepted.

Sharp will not be responsible for the Sharp product due to the malfunction or failures thereof which are caused by:

- (1) storage keep trouble during the inventory in the marketing channel.
- (2) intentional act, negligence or wrong/poor handling.
- (3) equipment which Sharp products are connected to or mounted in.
- (4) disassembling, reforming or changing Sharp products.
- (5) installation problem.
- (6) act of God or other disaster (natural disaster, fire, flood, etc.)
- (7) external factors (abnormal voltage, abnormal electromagnetic wave, fire, etc.)
- (8) special environment (factory, coastal areas, hot spring area, etc.)
- (9) phenomenon which cannot be foreseen based on the practical technologies at the time of shipment.
- (10) the factors not included in the product specification sheet.

4. Please contact and consult with a Sharp sales representative for any questions about Sharp product.

## 1. Application

This specification applies to the outline and characteristics of OPIC photocoupler Model No. PC400.

2. Outline Refer to page 4.

3. Ratings and characteristics Refer to page 5 to 7.

4. Reliability Refer to page 8.

5. Outgoing inspection Refer to page 9.

## 6. Supplement

6.1 Isolation voltage shall be measured in the following method.

- (1) Short between pins 1 and 3 on the primary side and between pins 4, 5 and 6 on the secondary side.
- (2) The dielectric withstanding tester with zero-cross circuit shall be used.
- (3) The wave form of applied voltage shall be a sine wave.

6.2 Package specification Refer to page 10 and 11.

6.3 The business dealing name used for this product when ordered or delivered shall be PC400J00000F.

6.4 This Model is approved by UL.

Approved Model No. : PC400

UL file No. : E64380

6.5 About radiation resistant design

- (1) This product is not designed against irradiation.
- (2) This product is assembled with electrical input and output.
- (3) This product incorporates non-coherent light emitting diode.

6.6 ODS materials

- (1) This product shall not contain the following materials.
- (2) Also, the following materials shall not be used in the production process for this product.

Materials for ODS : CFCs, Halon, Carbon tetrachloride, 1,1,1-Trichloroethane (Methyl chloroform)

6.7 Specified brominated flame retardants

Specified brominated flame retardants (PBB and PBDE) are not used in this device at all.

6.8 Compliance with each regulation

- (1) This product complies with EU RoHS Directive (2011/65/EU) and Commission Delegated Directive (EU)2015/863.
- (2) Content of six substances specified in Management Methods for Control of Pollution Caused by Electronic Information Products Regulation (Chinese : 电子信息产品污染控制管理办法).

Marking Styles for the Names and Contents of the Hazardous Substances

Category	Hazardous Substances					
	Lead (Pb)	Mercury (Hg)	Cadmium (Cd)	Hexavalent chromium (Cr <sup>6+</sup> )	Polybrominated biphenyls (PBB)	Polybrominated diphenyl ethers (PBDE)
Photocoupler	○	○	○	○	○	○

This table is prepared in accordance with the provisions of SJ/T 11364.

○ : Indicates that said hazardous substance contained in all of the homogeneous materials for this part is below the limit requirement of GB/T 26572.

6.9 Explanation of operation

- (1) When the forward current over the “H→L” threshold input current (IFHL) is flows on the input side, the output goes to “Low level”.
- (2) When the forward current goes below the "L→H" threshold input current (IFLH) is flows on the input side, the output goes to "High level".

7. Notes

Precautions for photocouplers : Attachment-1

2. Outline

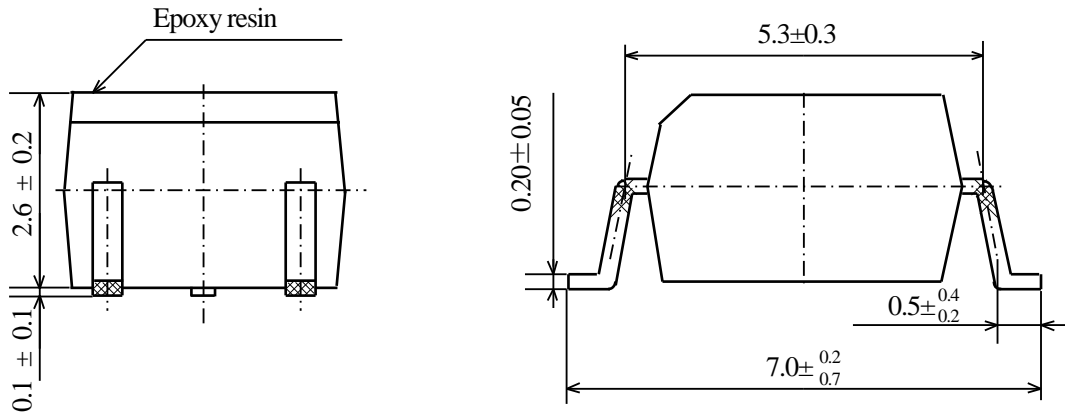
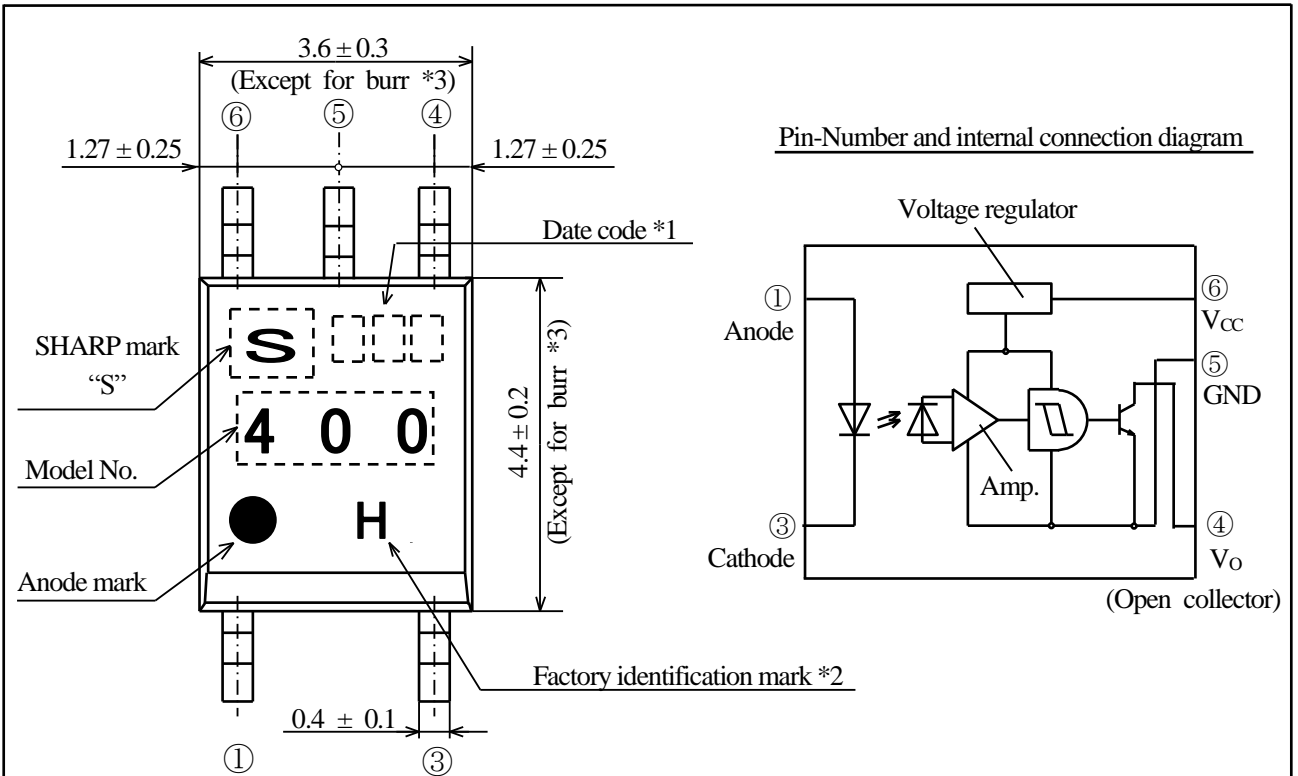

\*1 Date code : 3 digit indication according to production year, month and day

\*2 Factory identification mark is as follows.

**H** : YONGYAO ENSEI ELECTRONICS (SHANGQIU) CO., LTD. (CHINA products)

\*3 Burr of resin max. 0.2 mm

Pin material: Copper Alloy

Pin finish : Palladium (Au flash plating)

Mark : Laser marking

Product mass : Approx. 0.1g

A lead tip area and a part of a lead side area

( area) are no-plating.

UNIT : mm

	UNIT : mm
Name	PC400 Outline Dimensions (Business dealing name : PC400J00000F)

3. Ratings and characteristics

3.1 Absolute maximum ratings

Ta=25°C

	Parameter	Symbol	Rating	Unit
Input	*1 Forward current	$I_F$	50	mA
	Reverse voltage	$V_R$	6	V
	Power dissipation	$P$	70	mW
Output	Supply voltage	$V_{CC}$	16	V
	High level output voltage	$V_{OH}$	16	V
	Low level output current	$I_{OL}$	50	mA
	*1 Collector power dissipation	$P_o$	130	mW
	*1 Total power dissipation	$P_{tot}$	150	mW
	*2 Isolation voltage	$V_{iso(rms)}$	3750	V
	Operating temperature	$T_{opr}$	-25 to +85	°C
	Storage temperature	$T_{stg}$	-40 to +125	°C
	*3 Soldering temperature	$T_{sol}$	260	°C

\*1 The deating factors of absolute maximum ratings due to ambient temperature are shown in Fig. 1 to 3.

\*2 AC for 1 min, 40 to 60%RH

\*3 For 10 s

3.2 Electro-optical characteristics

Ta=0 to 70°C unless otherwise specified

Parameter		Symbol	Conditions	MIN.	TYP.	MAX.	Unit	
Input	Forward voltage	V <sub>F</sub>	I <sub>F</sub> =4mA	-	1.1	1.4	V	
			I <sub>F</sub> =0.3mA	0.7	1.0	-	V	
	Reverse current	I <sub>R</sub>	Ta=25°C, V <sub>R</sub> =3V	-	-	10	μA	
Terminal capacitance		C <sub>t</sub>	Ta=25°C, V <sub>F</sub> =0, f=1MHz	-	30	250	pF	
Output	Operating supply voltage range		V <sub>CC</sub>	3	-	15	V	
	Low level output voltage		V <sub>OL</sub>	I <sub>OL</sub> =16mA, V <sub>CC</sub> =5V, I <sub>F</sub> =4mA	-	0.2	0.4	V
	High level output current		I <sub>OH</sub>	V <sub>CC</sub> =V <sub>O</sub> =15V, I <sub>F</sub> =0	-	-	100	μA
	Low level supply current		I <sub>CCL</sub>	V <sub>CC</sub> =5V, I <sub>F</sub> =4mA	-	2.5	5.0	mA
	High level supply current		I <sub>CCH</sub>	V <sub>CC</sub> =5V, I <sub>F</sub> =0	-	1.0	5.0	mA
Transfer characteristics	"H→L" threshold input current *1	I <sub>FHL</sub>	Ta=25°C, V <sub>CC</sub> =5V, R <sub>L</sub> =280Ω	-	1.1	2.0	mA	
			V <sub>CC</sub> =5V, R <sub>L</sub> =280Ω	-	-	4.0		
	"L→H" threshold input current *2	I <sub>FLH</sub>	Ta=25°C, V <sub>CC</sub> =5V, R <sub>L</sub> =280Ω	0.4	0.8	-	mA	
			V <sub>CC</sub> =5V, R <sub>L</sub> =280Ω	0.3	-	-		
	Hysteresis *3		I <sub>FLH</sub> / I <sub>FHL</sub>	V <sub>CC</sub> =5V, R <sub>L</sub> =280Ω	0.5	0.7	0.9	
	Isolation resistance		R <sub>ISO</sub>	Ta=25°C, DC500V, 40 to 60%RH	5×10 <sup>10</sup>	10 <sup>11</sup>	-	Ω
	Response time *4	"H→L" propagation delay time	t <sub>PHL</sub>	Ta=25°C, V <sub>CC</sub> =5V, I <sub>F</sub> =4mA, R <sub>L</sub> =280Ω	-	1	3	μs
		"L→H" propagation delay time	t <sub>PLH</sub>		-	2	6	
Fall time		t <sub>f</sub>	-		0.05	0.5		
Rise time		t <sub>r</sub>	-		0.1	0.5		

\*1 I<sub>FHL</sub> represents forward current when output changes from "H" to "L".

\*2 I<sub>FLH</sub> represents forward current when output changes from "L" to "H".

\*3 Hysteresis : I<sub>FLH</sub> / I<sub>FHL</sub>

\*4 Test circuit for response time shall be shown below.

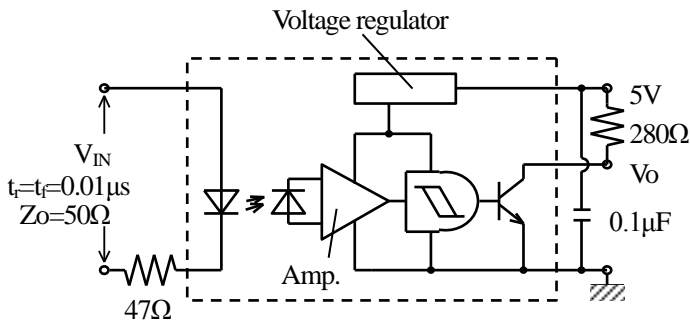

The circuit diagram

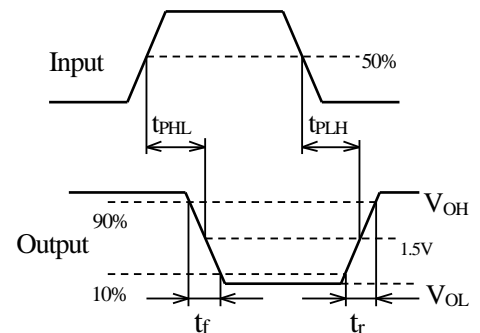

Timing chart

(Fig. 1) Forward current vs. ambient temperature

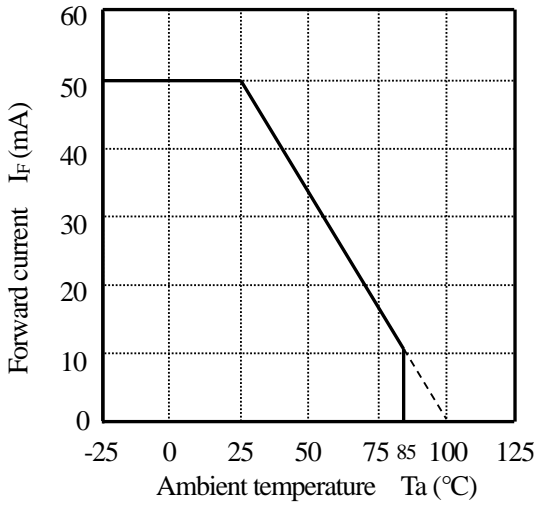

(Fig. 2) Output power dissipation vs. ambient temperature

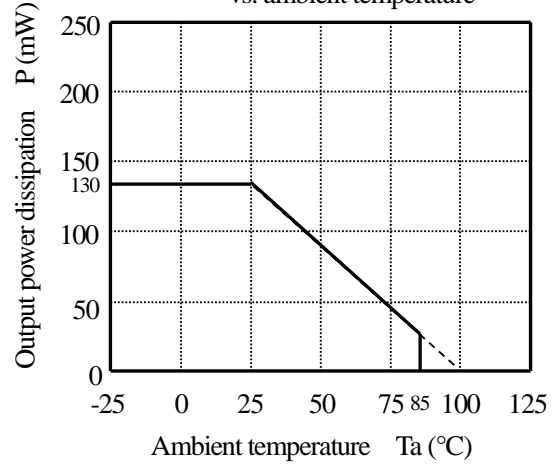

(Fig. 3) Total power dissipation vs. ambient temperature

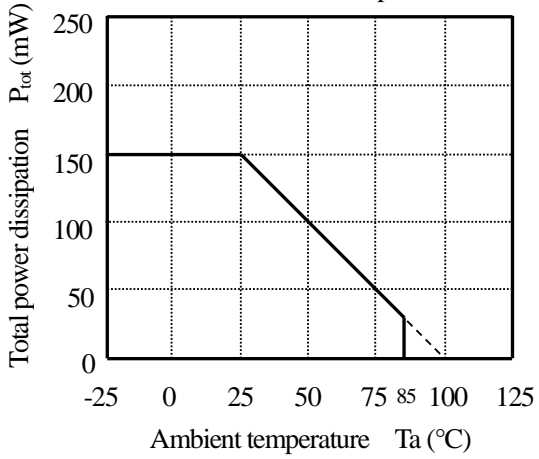

4. Reliability

The reliability of products shall satisfy items listed below.

Confidence level : 90%

LTPD : 10 or 20

Test Items	Test Conditions *1	Failure Judgment Criteria	Samples (n)
			Defective(C)
Solderability	245±3°C, 5 s	*2	n=11, C=0
Soldering heat *3	(Flow soldering) 260°C, 10 s	$V_F > U \times 1.2$ $I_R > U \times 2$ $V_{OL} > U \times 1.2$ $I_{OH} > U \times 1.2$ $I_{CCL} > U \times 1.2$ $I_{CCH} > U \times 1.2$ $I_{FHL} > U \times 1.3$ $I_{FLH} < L \times 0.8$ $I_{FLH} / I_{FHL} \neq L \times 0.8$ $\sim U \times 1.2$  U : Upper specification limit L : Lower specification limit	n=11, C=0
	(Soldering by hand) 400°C, 3 s		n=11, C=0
Terminal strength (Bending) *4	Weight : 1N, 1 time/each terminal		n=11, C=0
Mechanical shock	15km/s <sup>2</sup> , 0.5ms 3 times/±X, ±Y, ±Z direction		n=11, C=0
Variable frequency vibration	100 to 2000 to 100Hz/4min, 200m/s <sup>2</sup> 4 times/ X, Y, Z direction		n=11, C=0
Temperature cycling	1 cycle -40°C to +125°C (30min) (30min) 20 cycles test		n=22, C=0
High temperature and high humidity storage *5	+85°C, 85%RH, 500h		n=22, C=0
High temperature storage	+125°C, 1000h		n=22, C=0
Low temperature storage	-40°C, 1000h		n=22, C=0
Operation life	I <sub>F</sub> =10mA, V <sub>CC</sub> =15V, I <sub>OL</sub> =16mA, T <sub>a</sub> =25°C, 1000h		n=22, C=0

- \*1 Test method, conforms to EIAJ ED 4701.
- \*2 The product whose not-soldered area is more than 5% for all of the dipped area and/or whose pinholes or voids are concentrated on one place shall be judged defect.
- \*3 It is evaluated due to the temperature profile in attachment-1.
- \*4 Terminal bending direction is shown below.
- \*5 It is evaluated after washing by specified solvent in attachment-1.

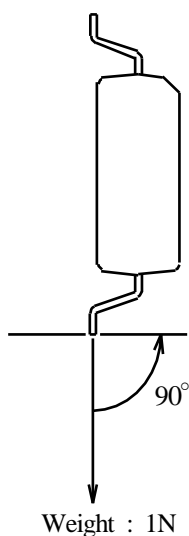

※ These test results are sampling examples from a specific lot for reference purpose only, and do not constitute any warranty or assurance in connection with the products.

## 5. Outgoing inspection

### 5.1 Inspection items

(1) Electrical characteristics

$V_F$ ,  $I_R$ ,  $V_{OL}$ ,  $I_{OH}$ ,  $I_{CCL}$ ,  $I_{CCH}$ ,  $I_{FHL}$ ,  $I_{FLH}$ ,  $R_{ISO}$ ,  $V_{iso}$

(2) Appearance

### 5.2 Sampling method and Inspection level

A single sampling plan, normal inspection level II based on ISO 2859 is applied.

The AQL according to the inspection items are shown below.

Defect	Inspection item	AQL (%)
Major defect	Electrical characteristics Unreadable marking	0.065
Minor defect	Appearance defect except the above mentioned.	0.25

6.2 Package specifications

6.2.1 Taping conditions

- (1) Tape structure and Dimensions (Refer to below.)

The carrier tape has the heat pressed structure of A-PET material carries tape with preventing static electricity and three layers cover tape (PET material base).

- (2) Reel structure and Dimensions (Refer to page 11.)

The taping reel shall be of plastic (PS material) .

- (3) Direction of product insertion (Refer to page 11.)

- (4) Joint of tape

The cover tape and carrier tape in one reel shall be joint less.

- (5) To repair failure - taped devices, cutting a bottom of carrier tape with a cutter.

After replacing the cut portion shall be sealed with adhesive tape.

6.2.2 Adhesiveness of cover tape

- The exfoliation force between carrier tape and cover tape shall be 0.2N to 0.7N for the angle 160° to 180°.

6.2.3 Rolling method and quantity

- Wind the tape back on the reel so that the cover tape will be outside the tape.

Attach more than 20cm of blank tape to the trailer and the leader of the tape and fix the both ends with adhesive tape.

One reel basically shall contain 3,000pcs.

6.2.4 Outer packing appearance (Refer to page 11.)

6.2.5 Marking

- The label with following information shall be pasted at appointed place of the outer packing case.

\* Model No. \*(Business dealing name) \* Lot No. \* Quantity

\* Country of origin \*Company name \*Inspection date specified

6.2.6 Storage condition

- Taped products shall be stored at the temperature 5°C to 30°C and the humidity 70%RH or less away from direct sunlight.

6.2.7 Safety protection during shipping

- There shall be no deformation of component or degradation of electrical characteristics due to shipping.

Carrier tape structure and Dimensions

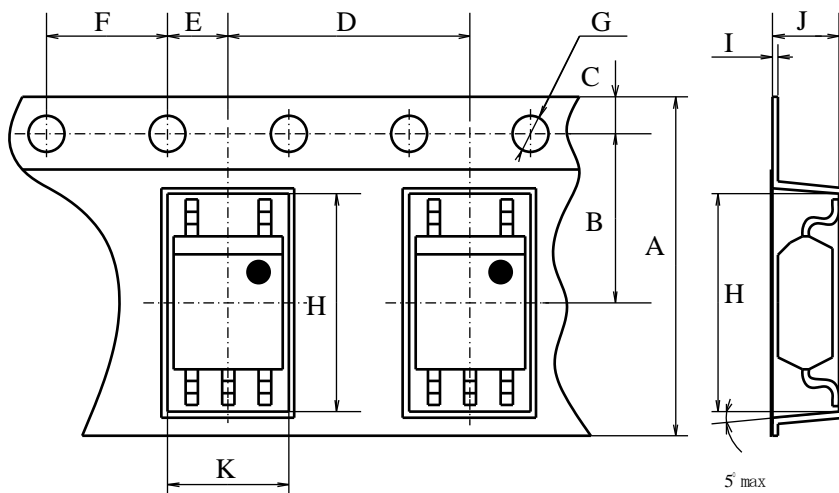

Dimensions list (Unit : mm)

A	B	C	D	E	F	G	H	I	J	K
±0.3	±0.05	±0.10	±0.1	±0.05	±0.1	+0.1 -0.0	±0.1	±0.05	±0.1	±0.1
12.0	5.50	1.75	8.0	2.00	4.0	φ1.5	7.4	0.30	3.1	4.0

Reel structure and Dimensions

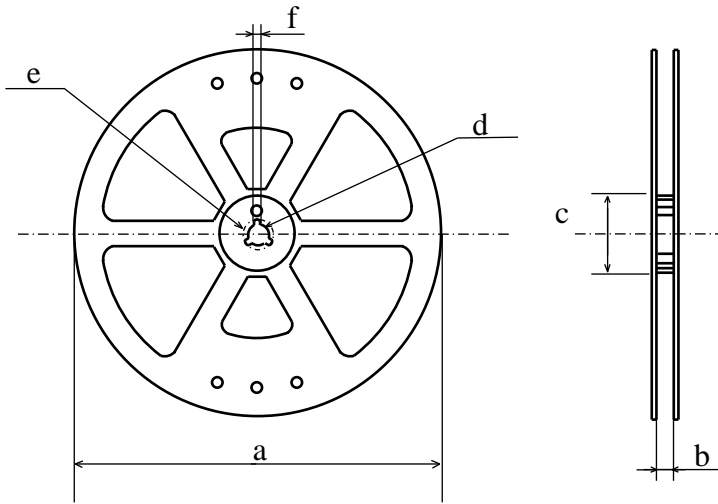

Dimensions list (Unit : mm)

a	b	c
(380)	13.4±1.0	φ80.0±1.0
d	e	f
φ13.0±0.2	φ21.0±0.8	2.0±0.5

Direction of product insertion

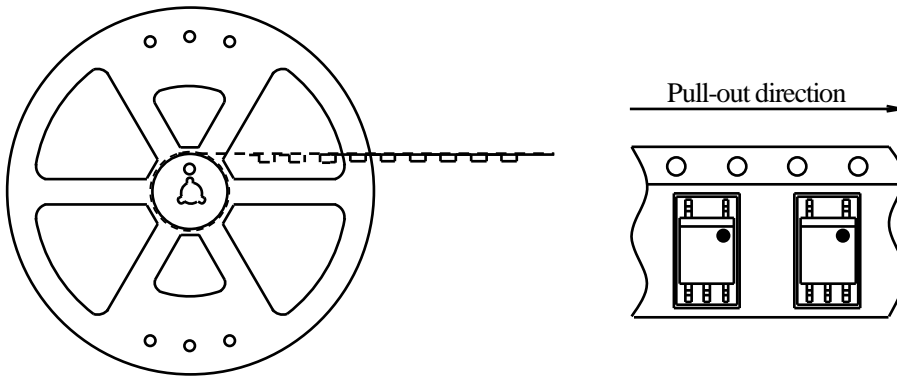

Outer packing appearance

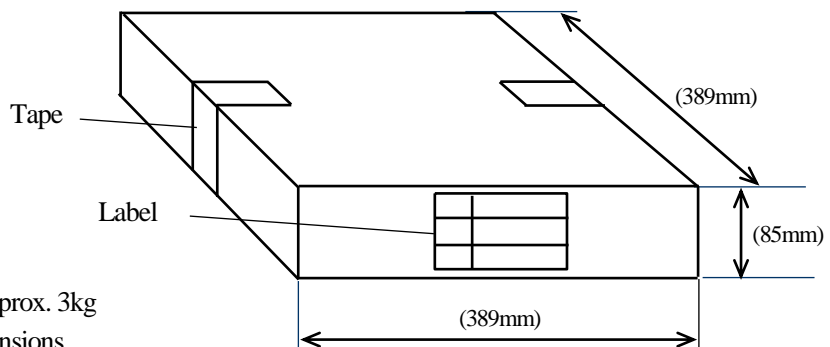
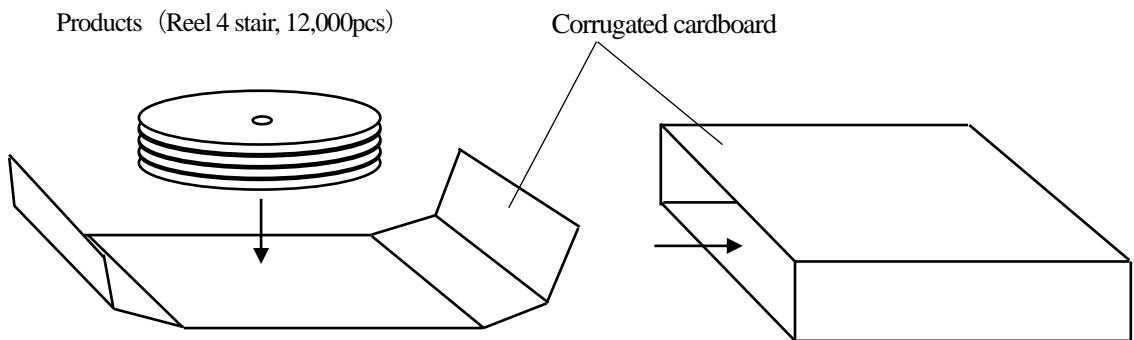

Regular packing mass : Approx. 3kg

( ) : Reference dimensions

Precautions for Photocouplers

## 1. Cleaning

- (1) Solvent cleaning : Solvent temperature 45°C or less  
Immersion for 3 min or less
- (2) Ultrasonic cleaning : The effect to device by ultrasonic cleaning differs by cleaning bath size, ultrasonic power output, cleaning time, PCB size or device mounting condition etc. Please test it in actual using condition and confirm that any defect doesn't occur before starting the ultrasonic cleaning.
- (3) Applicable solvent : Ethyl alcohol, Methyl alcohol, Isopropyl alcohol  
When the other solvent is used, there are cases that the packaging resin is eroded.  
Please use the other solvent after thorough confirmation is performed in actual using condition.

## 2. Static electricity

Transistor of detector side in bipolar configuration is apt to be affected by static electricity for its minute design. When handling them, general counterpane against static electricity should be taken to avoid breakdown of devices or degradation of characteristics.

## 3. Circuit design

- (1) In order to stabilize power supply line, we recommend to connect a by-pass capacitor of 0.01 $\mu$ F or more between  $V_{CC}$  and GND near the device.
- (2) The LED used in the Photocoupler generally decreases the light emission power by operation. In case of long operation time, please design  $I_F$  value so that  $I_F$  is twice or more of the Maximum value of the "H→L" threshold input current at circuit design with considering the decreases of the light emission power of the LED. (50%/5years)
- (3) The detector which is used in this device has parasitic diode between each pins and GND. There are cases that miss operation or destruction may be occurred if electric potential of any pin fall below GND level in an instant. Therefore it is recommended to design the circuit that electric potential of any pin does not become below GND level.
- (4) When steep voltage noise is applied between the primary side and the secondary side of the photocoupler, current flows or changes in the light emitting diode through a parasitic capacitance between the primary side and the secondary side of the photocoupler, then there is a case that miss operation occurs depending upon the applied noise level. We should certainly recommend to use a by-pass capacitor between both terminals of the light emitting diode when used in noisy environment.

#### 4. Precautions for Soldering

(1) In the case of flow soldering (Whole dipping is possible.)

It is recommended that flow soldering should be at 260°C or less for 10 s or less

(Pre-heating : 100 to 150°C, 30 to 80s). (2 times or less)

(2) If solder reflow :

It is recommended to be done at the temperature and the time within the temperature profile as shown in the figure below. (2 times or less)

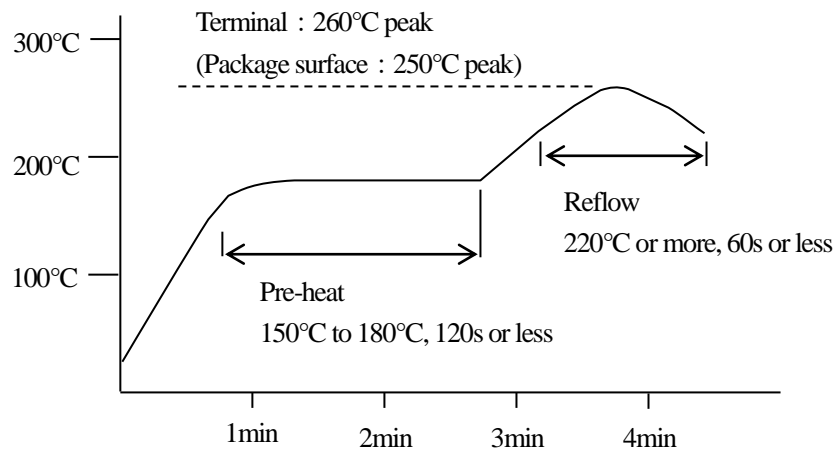

(3) In the case of hand soldering

What is done on the following condition is recommended. (2 times or less)

Soldering iron temperature : 400°C or less

Time : 3s or less

(4) Other precautions

Depending on equipment and soldering conditions (temperature, Using solder etc.), the effect to the device and the PCB is different. Please confirm that there is no problem on the actual use conditions in advance.