

SN75ALS174A Quadruple Differential Line Driver

1 Features

- Meets or exceeds the requirements of ANSI EIA/TIA-422-B and RS-485
- High-speed advanced low-power Schottky circuitry
- Designed for up to 20Mbit/s operation in both serial and parallel applications
- Designed for multipoint transmission on long bus lines in noisy environments
- Low supply current requirements 55mA max
- Wide positive and negative input/output bus voltage ranges
- Driver output capacity: 60mA
- Thermal-shutdown protection
- Driver positive- and negative-current limiting
- Functionally interchangeable with SN75174

2 Applications

- [Motor drives](#)
- [Factory automation and control](#)

3 Description

The SN75ALS174A is a quadruple line driver with tri-state differential outputs. It is designed to meet the requirements of ANSI Standards EIA/TIA-422-B and RS-485. This device is optimized for balanced multipoint bus transmission at rates of up to 20Mbit/s.

Each driver features wide positive and negative common-mode output voltage ranges that make them suitable for party-line applications in noisy environments.

The SN75ALS174A provides positive- and negative-current limiting and thermal shutdown for protection from line fault conditions on the transmission bus line. Shutdown occurs at a junction temperature of approximately 150°C.

The SN75ALS174A is characterized for operation from 0°C to 70°C.

Package Information

PART NUMBER	PACKAGE ⁽¹⁾	PACKAGE SIZE ⁽²⁾
SN75ALS174A	PDIP (N) (16)	19.3mm x 9.4mm
	SOIC (DW) (20)	12.8mm x 10.3mm
	TSSOP (PW) (20)	6.5mm x 6.4mm

(1) For more information, see [Section 10](#).

(2) The package size (length × width) is a nominal value and includes pins, where applicable.

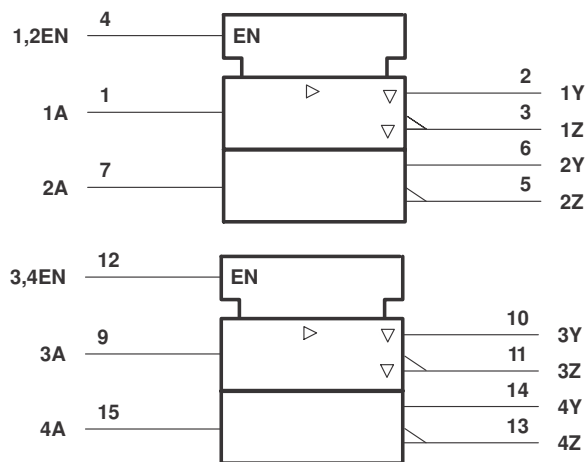

A. Pin numbers shown are for the N package.

Logic Symbol ¹

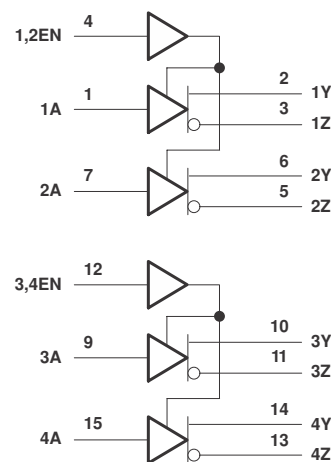

A. Pin numbers shown are for the N package.

Logic Diagram (Positive Logic)

¹ This symbol is in accordance with ANSI/IEEE Std 91-1984 and IEC Publication 617-12.



Table of Contents

1 Features	1	7 Detailed Description	8
2 Applications	1	7.1 Device Functional Modes.....	8
3 Description	1	8 Device and Documentation Support	9
4 Pin Configuration and Functions	3	8.1 Documentation Support.....	9
5 Specifications	4	8.2 Receiving Notification of Documentation Updates.....	9
5.1 Absolute Maximum Ratings.....	4	8.3 Support Resources.....	9
5.2 Dissipation Rating Table.....	4	8.4 Trademarks.....	9
5.3 Recommended Operating Conditions.....	4	8.5 Electrostatic Discharge Caution.....	9
5.4 Thermal Information.....	4	8.6 Glossary.....	9
5.5 Electrical Characteristics.....	5	9 Revision History	9
5.6 Switching Characteristics.....	5	10 Mechanical, Packaging, and Orderable	
6 Parameter Measurement Information	6	Information	9

4 Pin Configuration and Functions

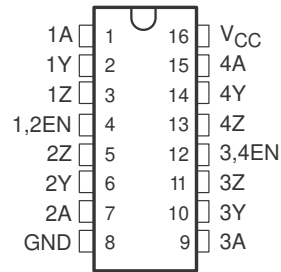

N Package (Top View)



NC – No internal connection

DW, PW Package (Top View)

5 Specifications

5.1 Absolute Maximum Ratings

over operating free-air temperature range (unless otherwise noted)⁽¹⁾

	MIN	MAX	UNIT
Supply voltage, V_{CC} ⁽²⁾	-0.5	7	V
Input voltage, V_I	-0.5	7	V
Output voltage range, V_O	-9	14	V
Continuous total dissipation	See the <i>Dissipation Rating</i> table		
Storage temperature, T_{stg}	-65	150	°C

- (1) Stresses beyond those listed under *Absolute Maximum Ratings* may cause permanent damage to the device. These are stress ratings only, which do not imply functional operation of the device at these or any other conditions beyond those indicated under *Recommended Operating Conditions*. Exposure to absolute-maximum-rated conditions for extended periods may affect device reliability.
- (2) All voltage values are with respect to network GND.

5.2 Dissipation Rating Table

PACKAGE	$T_A \leq 25^\circ\text{C}$ POWER RATING	DERATING FACTOR	$T_A = 70^\circ\text{C}$ POWER RATING	$T_A = 85^\circ\text{C}$ POWER RATING
DW	1125 mW	9.0 mW/°C	720 mW	596 mW
N	1150 mW	9.2 mW/°C	736 mW	598 mW

5.3 Recommended Operating Conditions

over operating free-air temperature range (unless otherwise noted)

		MIN	NOM	MAX	UNIT
V_{CC}	Supply voltage	4.75	5	5.25	V
V_{IH}	High-level input voltage	2		V_{CC}	V
V_{IL}	Low-level input voltage	0		0.8	V
V_{OC}	Common-mode output voltage	-7		12	V
I_{OH}	High-level output current	0		-60	mA
I_{OL}	Low-level output current	0		60	mA
T_A	Operating free-air temperature	0		70	°C

5.4 Thermal Information

THERMAL METRIC ⁽¹⁾	SN75ALS174A			UNIT	
	N (PDIP)	DW (SOIC)	PW		
	16 PINS	20 PINS	20 PINS		
$R_{\theta JA}$	Junction-to-ambient thermal resistance	60.6	66.8	107.5	°C/W
$R_{\theta JC(top)}$	Junction-to-case (top) thermal resistance	48.1	34.4	38.4	°C/W
$R_{\theta JB}$	Junction-to-board thermal resistance	40.6	39.7	53.7	°C/W
ψ_{JT}	Junction-to-top characterization parameter	27.5	8.9	3.2	°C/W
ψ_{JB}	Junction-to-board characterization parameter	40.3	39	53.1	°C/W
$R_{\theta JC(bot)}$	Junction-to-case (bottom) thermal resistance	n/a	n/a	n/a	°C/W

- (1) For more information about traditional and new thermal metrics, see the [Semiconductor and IC Package Thermal Metrics](#) application report.

5.5 Electrical Characteristics

over operating free-air temperature range (unless otherwise noted)

PARAMETER		TEST CONDITIONS	MIN	TYP ⁽¹⁾	MAX	UNIT
V_{IK}	Input clamp voltage	$I_I = -18\text{mA}$			-1.5	V
V_O	Output voltage	$I_O = 0$	0		6	V
$ V_{OD1} $	Differential output voltage	$I_O = 0$	1.5		6	V
$ V_{OD2} $	Differential output voltage	$R_L = 100\Omega$	See Note Figure 6-1			$1/2 V_{OD1}$ or 2 ⁽²⁾
		$R_L = 54\Omega$				1.5
$ V_{OD3} $	Differential output voltage	See ⁽⁵⁾	1.5		5	V
$\Delta V_{OD} $	Change in magnitude of differential output voltage ⁽³⁾	$R_L = 54\Omega$ or 100Ω	See Figure 6-1		± 0.2	V
V_{OC}	Common-mode output voltage ⁽⁴⁾	$R_L = 54\Omega$ or 100Ω	See Figure 6-1		3	V
					-1	V
$\Delta V_{OC} $	Change in magnitude of common-mode output voltage ⁽³⁾	$R_L = 54\Omega$ or 100Ω	See Figure 6-1		± 0.2	V
I_O	Output current with power off	$V_{CC} = 0, V_O = -7\text{V to } 12\text{V}$			± 100	μA
I_{OZ}	High-impedance-state output current	$V_O = -7\text{V to } 12\text{V}$			± 100	μA
I_{IH}	High-level input current	$V_I = 2.7\text{V}$			20	μA
I_{IL}	Low-level input current	$V_I = 0.4\text{V}$			-100	μA
I_{OS}	Short-circuit output current	$V_O = -7\text{V to } 12\text{V}$			± 250	mA
I_{CC}	Supply current (all drivers)	No load	Outputs enabled	36	55	mA
			Outputs disabled	16	30	mA

(1) All typical values are at $V_{CC} = 5\text{V}$ and $T_A = 25^\circ\text{C}$.

(2) The minimum V_{OD2} with a 100Ω load is either $1/2V_{OD1}$ or 2V , whichever is greater.

(3) $\Delta|V_{OD}|$ and $\Delta|V_{OC}|$ are the changes in magnitude of V_{OD} and V_{OC} , respectively, that occur when the input is changed from a high level to a low level.

(4) In ANSI Standard EIA/TIA-422-B, V_{OC} , which is the average of the two output voltages with respect to ground, is called output offset voltage, V_{OS} .

(5) See EIA Standard RS-485, Figures 3-5, Test Termination Measurement 2.

5.6 Switching Characteristics

over operating free-air temperature range (unless otherwise noted), $C_L = 50\text{pF}$

PARAMETER		TEST CONDITIONS	MIN	TYP	MAX	UNIT
$t_{d(OD)}$	Differential output delay time	$R_L = 54\Omega$, See Figure 6-2	9	15	22	ns
t_{PZH}	Output enable time to high level	$R_L = 110\Omega$, See Figure 6-3	30	45	70	ns
t_{PZL}	Output enable time to low level	$R_L = 110\Omega$, See Figure 6-4	25	40	65	ns
t_{PHZ}	Output disable time from high level	$R_L = 110\Omega$, See Figure 6-3	10	20	35	ns
t_{PLZ}	Output disable time from low level	$R_L = 110\Omega$, See Figure 6-4	10	30	45	ns

6 Parameter Measurement Information

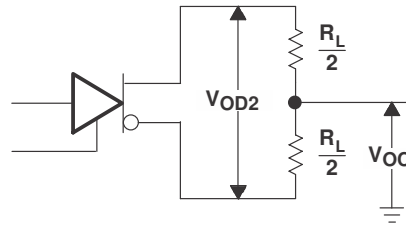

Copyright © 2018, Texas Instruments Incorporated

Figure 6-1. Differential and Common-Mode Output Voltages

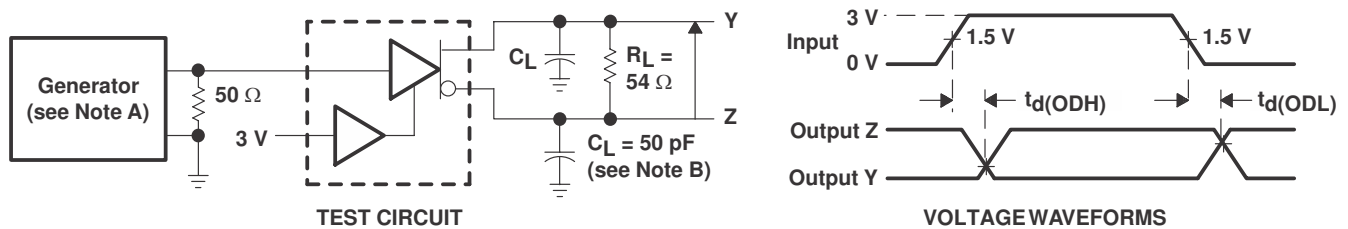

Copyright © 2018, Texas Instruments Incorporated

- A. The input pulse is supplied by a generator having the following characteristics: PRR = 1MHz, $Z_O = 50\Omega$, duty cycle = 50%, t_r 5ns, t_f 5ns.
- B. C_L includes probe and stray capacitance.

Figure 6-2. Differential-Output Test Circuit and Delay and Transition Times Voltage Waveforms

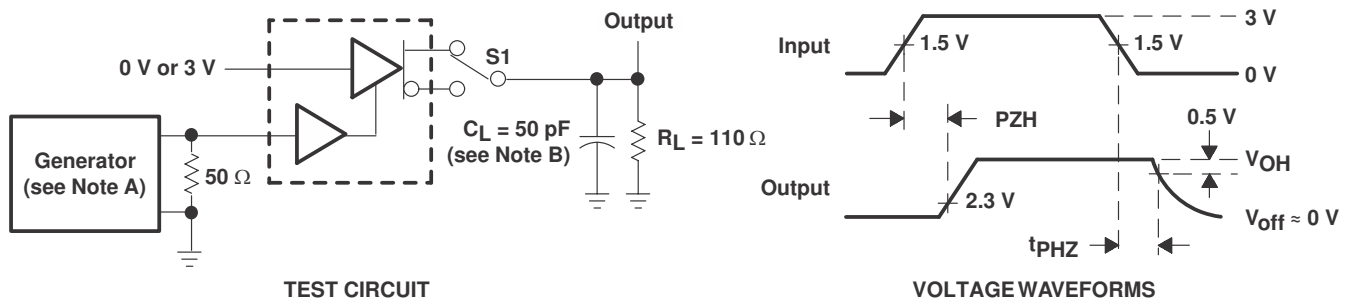

Copyright © 2018, Texas Instruments Incorporated

- A. The input pulse is supplied by a generator having the following characteristics: PRR = 1MHz, $Z_O = 50\Omega$, duty cycle = 50%, t_r 10ns, t_f 10ns.
- B. C_L includes probe and stray capacitance.

Figure 6-3. Test Circuit and Voltage Waveforms, t_{PZH} and t_{PHZ}

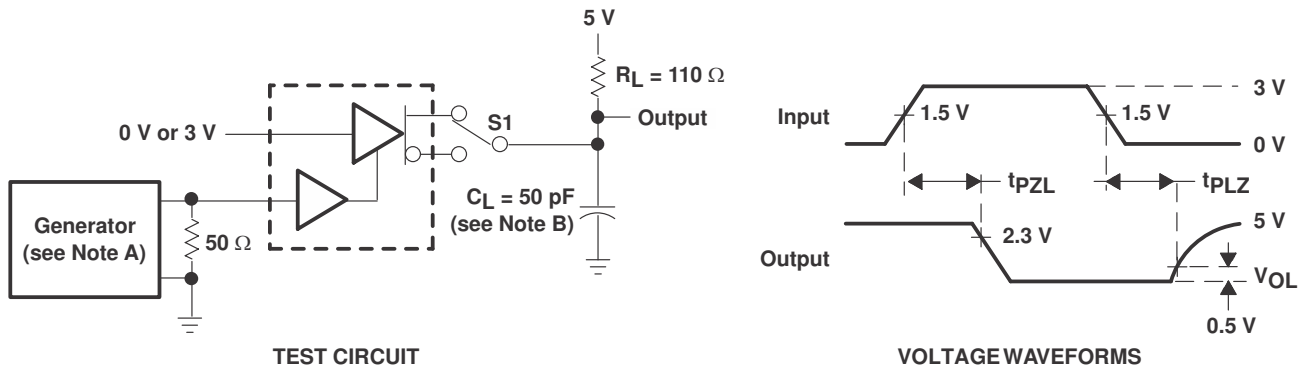

Copyright © 2018, Texas Instruments Incorporated

- A. The input pulse is supplied by a generator having the following characteristics: PRR = 1MHz, $Z_O = 50\Omega$, duty cycle = 50%, t_r 5ns, t_f 5ns.
- B. C_L includes probe and stray capacitance.

Figure 6-4. Test Circuit and Voltage Waveforms, t_{pZL} and t_{pLZ}

7 Detailed Description

7.1 Device Functional Modes

Function Table (each driver)

INPUT A ^{(1) (2)}	ENABLES	OUTPUTS	
		Y	Z
H	H	H	L
L	H	L	H
X	L	Z	Z

- (1) H = high level, L = low level, X = irrelevant.
 (2) Z = high impedance (off)

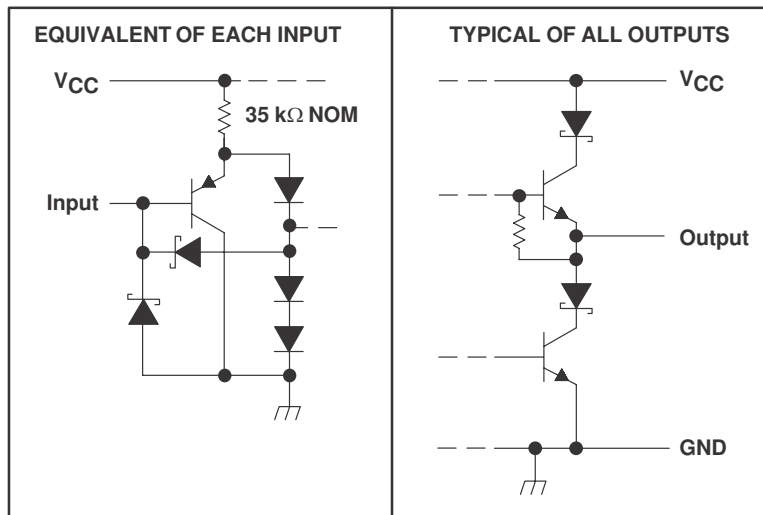

Copyright © 2018, Texas Instruments Incorporated

Figure 7-1. Schematics of Inputs and Outputs

8 Device and Documentation Support

8.1 Documentation Support

8.2 Receiving Notification of Documentation Updates

To receive notification of documentation updates, navigate to the device product folder on ti.com. Click on *Notifications* to register and receive a weekly digest of any product information that has changed. For change details, review the revision history included in any revised document.

8.3 Support Resources

[TI E2E™ support forums](#) are an engineer's go-to source for fast, verified answers and design help — straight from the experts. Search existing answers or ask your own question to get the quick design help you need.

Linked content is provided "AS IS" by the respective contributors. They do not constitute TI specifications and do not necessarily reflect TI's views; see TI's [Terms of Use](#).

8.4 Trademarks

TI E2E™ is a trademark of Texas Instruments.
All trademarks are the property of their respective owners.

8.5 Electrostatic Discharge Caution



This integrated circuit can be damaged by ESD. Texas Instruments recommends that all integrated circuits be handled with appropriate precautions. Failure to observe proper handling and installation procedures can cause damage.

ESD damage can range from subtle performance degradation to complete device failure. Precision integrated circuits may be more susceptible to damage because very small parametric changes could cause the device not to meet its published specifications.

8.6 Glossary

[TI Glossary](#) This glossary lists and explains terms, acronyms, and definitions.

9 Revision History

NOTE: Page numbers for previous revisions may differ from page numbers in the current version.

Changes from Revision F (January 2018) to Revision G (April 2024)	Page
• Changed the numbering format for tables, figures, and cross-references throughout the document.....	1
• Added the <i>Thermal Information</i> table.....	4
• Changed Note A in Figure 6-3	6

Changes from Revision E (April 1998) to Revision F (January 2018)	Page
• Added the PW package, <i>Applications</i> list, <i>Device Information</i> table, <i>Device and Documentation Support</i> section, and <i>Mechanical, Packaging, and Orderable Information</i> section.	1

10 Mechanical, Packaging, and Orderable Information

The following pages include mechanical, packaging, and orderable information. This information is the most current data available for the designated devices. This data is subject to change without notice and revision of this document. For browser-based versions of this data sheet, refer to the left-hand navigation.

PACKAGING INFORMATION

Orderable Device	Status (1)	Package Type	Package Drawing	Pins	Package Qty	Eco Plan (2)	Lead finish/ Ball material (6)	MSL Peak Temp (3)	Op Temp (°C)	Device Marking (4/5)	Samples
SN75ALS174ADWR	ACTIVE	SOIC	DW	20	2000	RoHS & Green	NIPDAU	Level-1-260C-UNLIM	0 to 70	75ALS174A	Samples
SN75ALS174AN	ACTIVE	PDIP	N	16	25	RoHS & Green	NIPDAU	N / A for Pkg Type	0 to 70	SN75ALS174AN	Samples
SN75ALS174APWR	ACTIVE	TSSOP	PW	20	2000	RoHS & Green	NIPDAU	Level-1-260C-UNLIM	0 to 70	LS174A	Samples

(1) The marketing status values are defined as follows:

ACTIVE: Product device recommended for new designs.

LIFEBUY: TI has announced that the device will be discontinued, and a lifetime-buy period is in effect.

NRND: Not recommended for new designs. Device is in production to support existing customers, but TI does not recommend using this part in a new design.

PREVIEW: Device has been announced but is not in production. Samples may or may not be available.

OBSOLETE: TI has discontinued the production of the device.

(2) **RoHS:** TI defines "RoHS" to mean semiconductor products that are compliant with the current EU RoHS requirements for all 10 RoHS substances, including the requirement that RoHS substance do not exceed 0.1% by weight in homogeneous materials. Where designed to be soldered at high temperatures, "RoHS" products are suitable for use in specified lead-free processes. TI may reference these types of products as "Pb-Free".

RoHS Exempt: TI defines "RoHS Exempt" to mean products that contain lead but are compliant with EU RoHS pursuant to a specific EU RoHS exemption.

Green: TI defines "Green" to mean the content of Chlorine (Cl) and Bromine (Br) based flame retardants meet JS709B low halogen requirements of <=1000ppm threshold. Antimony trioxide based flame retardants must also meet the <=1000ppm threshold requirement.

(3) MSL, Peak Temp. - The Moisture Sensitivity Level rating according to the JEDEC industry standard classifications, and peak solder temperature.

(4) There may be additional marking, which relates to the logo, the lot trace code information, or the environmental category on the device.

(5) Multiple Device Markings will be inside parentheses. Only one Device Marking contained in parentheses and separated by a "~" will appear on a device. If a line is indented then it is a continuation of the previous line and the two combined represent the entire Device Marking for that device.

(6) Lead finish/Ball material - Orderable Devices may have multiple material finish options. Finish options are separated by a vertical ruled line. Lead finish/Ball material values may wrap to two lines if the finish value exceeds the maximum column width.

Important Information and Disclaimer:The information provided on this page represents TI's knowledge and belief as of the date that it is provided. TI bases its knowledge and belief on information provided by third parties, and makes no representation or warranty as to the accuracy of such information. Efforts are underway to better integrate information from third parties. TI has taken and continues to take reasonable steps to provide representative and accurate information but may not have conducted destructive testing or chemical analysis on incoming materials and chemicals. TI and TI suppliers consider certain information to be proprietary, and thus CAS numbers and other limited information may not be available for release.

In no event shall TI's liability arising out of such information exceed the total purchase price of the TI part(s) at issue in this document sold by TI to Customer on an annual basis.

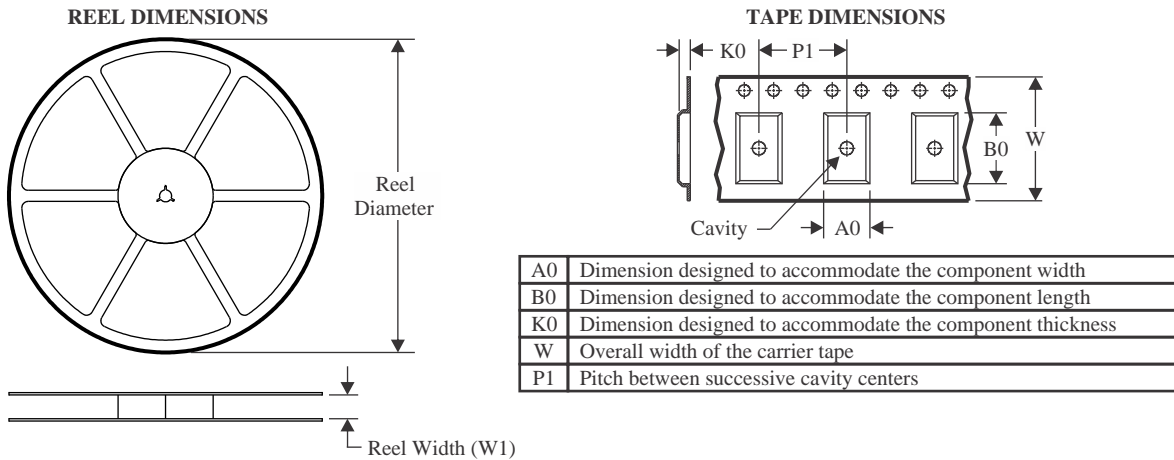
TAPE AND REEL INFORMATION

QUADRANT ASSIGNMENTS FOR PIN 1 ORIENTATION IN TAPE

*All dimensions are nominal

Device	Package Type	Package Drawing	Pins	SPQ	Reel Diameter (mm)	Reel Width W1 (mm)	A0 (mm)	B0 (mm)	K0 (mm)	P1 (mm)	W (mm)	Pin1 Quadrant
SN75ALS174ADWR	SOIC	DW	20	2000	330.0	24.4	10.8	13.3	2.7	12.0	24.0	Q1
SN75ALS174APWR	TSSOP	PW	20	2000	330.0	16.4	6.95	7.1	1.6	8.0	16.0	Q1

TAPE AND REEL BOX DIMENSIONS

*All dimensions are nominal

Device	Package Type	Package Drawing	Pins	SPQ	Length (mm)	Width (mm)	Height (mm)
SN75ALS174ADWR	SOIC	DW	20	2000	350.0	350.0	43.0
SN75ALS174APWR	TSSOP	PW	20	2000	356.0	356.0	35.0

TUBE

*All dimensions are nominal

Device	Package Name	Package Type	Pins	SPQ	L (mm)	W (mm)	T (μm)	B (mm)
SN75ALS174ADW	DW	SOIC	20	25	506.98	12.7	4826	6.6
SN75ALS174AN	N	PDIP	16	25	506	13.97	11230	4.32

N (R-PDIP-T**)

PLASTIC DUAL-IN-LINE PACKAGE

16 PINS SHOWN



- NOTES:
- A. All linear dimensions are in inches (millimeters).
 - B. This drawing is subject to change without notice.
 - Falls within JEDEC MS-001, except 18 and 20 pin minimum body length (Dim A).
 - The 20 pin end lead shoulder width is a vendor option, either half or full width.

DW0020A



PACKAGE OUTLINE

SOIC - 2.65 mm max height

SOIC



4220724/A 05/2016

NOTES:

1. All linear dimensions are in millimeters. Dimensions in parenthesis are for reference only. Dimensioning and tolerancing per ASME Y14.5M.
2. This drawing is subject to change without notice.
3. This dimension does not include mold flash, protrusions, or gate burrs. Mold flash, protrusions, or gate burrs shall not exceed 0.15 mm per side.
4. This dimension does not include interlead flash. Interlead flash shall not exceed 0.43 mm per side.
5. Reference JEDEC registration MS-013.

EXAMPLE BOARD LAYOUT

DW0020A

SOIC - 2.65 mm max height

SOIC



LAND PATTERN EXAMPLE
SCALE:6X



SOLDER MASK DETAILS

4220724/A 05/2016

NOTES: (continued)

- 6. Publication IPC-7351 may have alternate designs.
- 7. Solder mask tolerances between and around signal pads can vary based on board fabrication site.

EXAMPLE STENCIL DESIGN

DW0020A

SOIC - 2.65 mm max height

SOIC



SOLDER PASTE EXAMPLE
BASED ON 0.125 mm THICK STENCIL
SCALE:6X

4220724/A 05/2016

NOTES: (continued)

8. Laser cutting apertures with trapezoidal walls and rounded corners may offer better paste release. IPC-7525 may have alternate design recommendations.
9. Board assembly site may have different recommendations for stencil design.

PW0020A



PACKAGE OUTLINE

TSSOP - 1.2 mm max height

SMALL OUTLINE PACKAGE



4220206/A 02/2017

NOTES:

1. All linear dimensions are in millimeters. Any dimensions in parenthesis are for reference only. Dimensioning and tolerancing per ASME Y14.5M.
2. This drawing is subject to change without notice.
3. This dimension does not include mold flash, protrusions, or gate burrs. Mold flash, protrusions, or gate burrs shall not exceed 0.15 mm per side.
4. This dimension does not include interlead flash. Interlead flash shall not exceed 0.25 mm per side.
5. Reference JEDEC registration MO-153.

EXAMPLE BOARD LAYOUT

PW0020A

TSSOP - 1.2 mm max height

SMALL OUTLINE PACKAGE



LAND PATTERN EXAMPLE
EXPOSED METAL SHOWN
SCALE: 10X



4220206/A 02/2017

NOTES: (continued)

- 6. Publication IPC-7351 may have alternate designs.
- 7. Solder mask tolerances between and around signal pads can vary based on board fabrication site.

EXAMPLE STENCIL DESIGN

PW0020A

TSSOP - 1.2 mm max height

SMALL OUTLINE PACKAGE



SOLDER PASTE EXAMPLE
BASED ON 0.125 mm THICK STENCIL
SCALE: 10X

4220206/A 02/2017

NOTES: (continued)

8. Laser cutting apertures with trapezoidal walls and rounded corners may offer better paste release. IPC-7525 may have alternate design recommendations.
9. Board assembly site may have different recommendations for stencil design.

PW (R-PDSO-G20)

PLASTIC SMALL OUTLINE



- NOTES:
- A. All linear dimensions are in millimeters.
 - B. This drawing is subject to change without notice.
 - C. Publication IPC-7351 is recommended for alternate design.
 - D. Laser cutting apertures with trapezoidal walls and also rounding corners will offer better paste release. Customers should contact their board assembly site for stencil design recommendations. Refer to IPC-7525 for other stencil recommendations.
 - E. Customers should contact their board fabrication site for solder mask tolerances between and around signal pads.

IMPORTANT NOTICE AND DISCLAIMER

TI PROVIDES TECHNICAL AND RELIABILITY DATA (INCLUDING DATA SHEETS), DESIGN RESOURCES (INCLUDING REFERENCE DESIGNS), APPLICATION OR OTHER DESIGN ADVICE, WEB TOOLS, SAFETY INFORMATION, AND OTHER RESOURCES "AS IS" AND WITH ALL FAULTS, AND DISCLAIMS ALL WARRANTIES, EXPRESS AND IMPLIED, INCLUDING WITHOUT LIMITATION ANY IMPLIED WARRANTIES OF MERCHANTABILITY, FITNESS FOR A PARTICULAR PURPOSE OR NON-INFRINGEMENT OF THIRD PARTY INTELLECTUAL PROPERTY RIGHTS.

These resources are intended for skilled developers designing with TI products. You are solely responsible for (1) selecting the appropriate TI products for your application, (2) designing, validating and testing your application, and (3) ensuring your application meets applicable standards, and any other safety, security, regulatory or other requirements.

These resources are subject to change without notice. TI grants you permission to use these resources only for development of an application that uses the TI products described in the resource. Other reproduction and display of these resources is prohibited. No license is granted to any other TI intellectual property right or to any third party intellectual property right. TI disclaims responsibility for, and you will fully indemnify TI and its representatives against, any claims, damages, costs, losses, and liabilities arising out of your use of these resources.

TI's products are provided subject to [TI's Terms of Sale](#) or other applicable terms available either on [ti.com](https://www.ti.com) or provided in conjunction with such TI products. TI's provision of these resources does not expand or otherwise alter TI's applicable warranties or warranty disclaimers for TI products.

TI objects to and rejects any additional or different terms you may have proposed.

Mailing Address: Texas Instruments, Post Office Box 655303, Dallas, Texas 75265
Copyright © 2024, Texas Instruments Incorporated