

## DS34C87T CMOS Quad TRI-STATE Differential Line Driver

 Check for Samples: [DS34C87T](#)

### FEATURES

- TTL Input Compatible
- Typical Propagation Delays: 6 ns
- Typical Output Skew: 0.5 ns
- Outputs Won't Load Line When  $V_{CC} = 0V$
- Meets the Requirements of EIA Standard RS-422
- Operation from Single 5V Supply
- TRI-STATE Outputs for Connection to System Buses
- Low Quiescent Current
- Available in Surface Mount

### DESCRIPTION

The DS34C87T is a quad differential line driver designed for digital data transmission over balanced lines. The DS34C87T meets all the requirements of EIA standard RS-422 while retaining the low power characteristics of CMOS. This enables the construction of serial and terminal interfaces while maintaining minimal power consumption.

The DS34C87T accepts TTL or CMOS input levels and translates these to RS-422 output levels. This part uses special output circuitry that enables the individual drivers to power down without loading down the bus. This device has separate enable circuitry for each pair of the four drivers. The DS34C87T is pin compatible to the DS3487T.

All inputs are protected against damage due to electrostatic discharge by diodes to  $V_{CC}$  and ground.

### Connection and Logic Diagrams

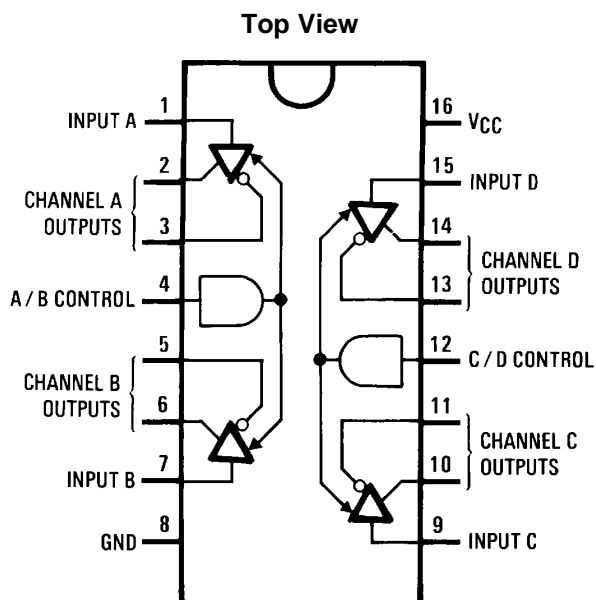

See [PIN DESCRIPTIONS](#) for details.

**Figure 1. PDIP Package**  
See Package Numbers D0016A or NFG0016E

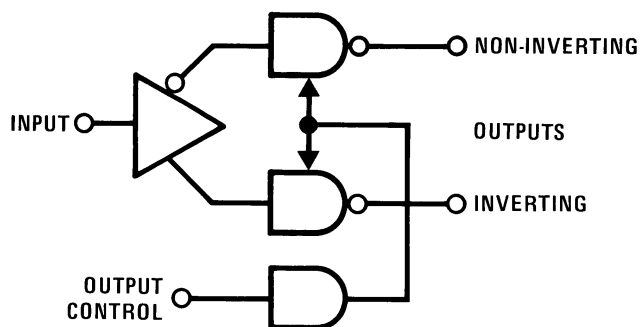

**Figure 2. Logic Diagram**



Please be aware that an important notice concerning availability, standard warranty, and use in critical applications of Texas Instruments semiconductor products and disclaimers thereto appears at the end of this data sheet.

All trademarks are the property of their respective owners.

Truth Table<sup>(1)</sup>

Input	Control	Non-Inverting	Inverting
	Input	Output	Output
H	H	H	L
L	H	L	H
X	L	Z	Z

- (1) L = Low logic state  
 H = High logic state  
 X = Irrelevant  
 Z = TRI-STATE (high performance)



These devices have limited built-in ESD protection. The leads should be shorted together or the device placed in conductive foam during storage or handling to prevent electrostatic damage to the MOS gates.

### Absolute Maximum Ratings<sup>(1)(2)(3)(4)</sup>

Supply Voltage ( $V_{CC}$ )	-0.5 to 7.0V
DC Voltage ( $V_{IN}$ )	-1.5 to $V_{CC} + 1.5V$
DC Output Voltage ( $V_{OUT}$ )	-0.5 to 7V
Clamp Diode Current ( $I_{IK}, I_{OK}$ )	$\pm 20$ mA
DC Output Current, per pin ( $I_{OUT}$ )	$\pm 150$ mA
DC $V_{CC}$ or GND Current ( $I_{CC}$ )	$\pm 150$ mA
Storage Temperature Range ( $T_{STG}$ )	-65°C to +150°C
Maximum Power Dissipation ( $P_D$ ) @ 25°C <sup>(5)</sup>	
PDIP Package	1736 mW
SOIC Package	1226 mW
Lead Temperature ( $T_L$ )	
(Soldering 4 sec)	260°C
<b>This device does not meet 2000V ESD rating.<sup>(6)</sup></b>	

- (1) Unless otherwise specified, all voltages are referenced to ground. All currents into device pins are positive; all currents out of device pins are negative.
- (2) Absolute Maximum Ratings are those values beyond which the safety of the device cannot be specified. They are not meant to imply that the device should be operated at these limits. The table of "Electrical Characteristics" provide conditions for actual device operation.
- (3) ESD Rating: HBM (1.5 k $\Omega$ , 100 pF) Inputs  $\geq 1500V$  Outputs  $\geq 1000V$  EIAJ (0 $\Omega$ , 200 pF) All Pins  $\geq 350V$
- (4) If Military/Aerospace specified devices are required, please contact the Texas Instruments Sales Office/ Distributors for availability and specifications.
- (5) Ratings apply to ambient temperature at 25°C. Above this temperature derate NFG0016E Package 13.89 mW/°C, and D0016A Package 9.80 mW/°C.
- (6) ESD Rating: HBM (1.5 k $\Omega$ , 100 pF) Inputs  $\geq 1500V$  Outputs  $\geq 1000V$  EIAJ (0 $\Omega$ , 200 pF) All Pins  $\geq 350V$

### Operating Conditions

	Min	Max	Units
Supply Voltage ( $V_{CC}$ )	4.50	5.50	V
DC Input or Output Voltage ( $V_{IN}, V_{OUT}$ )	0	$V_{CC}$	V
Operating Temperature Range ( $T_A$ ) DS34C87T	-40	+85	°C
Input Rise or Fall Times ( $t_r, t_f$ )		500	ns

## DC Electrical Characteristics<sup>(1)</sup>

 $V_{CC} = 5V \pm 10\%$  (unless otherwise specified)

Parameter		Test Conditions	Min	Typ	Max	Units
$V_{IH}$	High Level Input Voltage		2.0			V
$V_{IL}$	Low Level Input Voltage				0.8	V
$V_{OH}$	High Level Output Voltage	$V_{IN} = V_{IH}$ or $V_{IL}$ , $I_{OUT} = -20$ mA	2.5	3.4		V
$V_{OL}$	Low Level Output Voltage	$V_{IN} = V_{IH}$ or $V_{IL}$ , $I_{OUT} = 48$ mA		0.3	0.5	V
$V_T$	Differential Output Voltage	$R_L = 100 \Omega$ See <sup>(2)</sup>	2.0	3.1		V
$ V_T  -  \bar{V}_T $	Difference In Differential Output	$R_L = 100 \Omega$ See <sup>(2)</sup>			0.4	V
$V_{OS}$	Common Mode Output Voltage	$R_L = 100 \Omega$ See <sup>(2)</sup>		2.0	3.0	V
$ V_{OS} - \bar{V}_{OS} $	Difference In Common Mode Output	$R_L = 100 \Omega$ See <sup>(2)</sup>			0.4	V
$I_{IN}$	Input Current	$V_{IN} = V_{CC}, GND, V_{IH},$ or $V_{IL}$			$\pm 1.0$	$\mu A$
$I_{CC}$	Quiescent Supply Current	$I_{OUT} = 0 \mu A$ , $V_{IN} = V_{CC}$ or GND $V_{IN} = 2.4V$ or $0.5V$ <sup>(3)</sup>		200 0.8	500 2.0	$\mu A$ mA
$I_{OZ}$	TRI-STATE Output Leakage Current	$V_{OUT} = V_{CC}$ or GND Control = $V_{IL}$		$\pm 0.5$	$\pm 5.0$	$\mu A$
$I_{SC}$	Output Short Circuit Current	$V_{IN} = V_{CC}$ or GND See <sup>(2)</sup> and <sup>(4)</sup>	-30		-150	mA
$I_{OFF}$	Power Off Output Leakage Current	$V_{CC} = 0V$ See <sup>(2)</sup>   $V_{OUT} = 6V$   $V_{OUT} = -0.25V$			100 -100	$\mu A$ $\mu A$

(1) Unless otherwise specified, min/max limits apply across the  $-40^\circ C$  to  $85^\circ C$  temperature range. All typicals are given for  $V_{CC} = 5V$  and  $T_A = 25^\circ C$ .

(2) See EIA Specification RS-422 for exact test conditions.

(3) Measured per input. All other inputs at  $V_{CC}$  or GND.

(4) This is the current sourced when a high output is shorted to ground. Only one output at a time should be shorted.

## Switching Characteristics<sup>(1)</sup>

$V_{CC} = 5V \pm 10\%$ ,  $t_r, t_f \leq 6 \text{ ns}$  (Figure 3, Figure 4, Figure 5, Figure 6)

Parameter		Test Conditions	Min	Typ	Max	Units
$t_{PLH}, t_{PHL}$	Propagation Delay Input to Output	S1 Open		6	11	ns
Skew	See <sup>(2)</sup>	S1 Open		0.5	3	ns
$t_{TLH}, t_{THL}$	Differential Output Rise And Fall Times	S1 Open		6	10	ns
$t_{PZH}$	Output Enable Time	S1 Closed		12	25	ns
$t_{PZL}$	Output Enable Time	S1 Closed		13	26	ns
$t_{PHZ}$	Output Disable Time <sup>(3)</sup>	S1 Closed		4	8	ns
$t_{PLZ}$	Output Disable Time <sup>(3)</sup>	S1 Closed		6	12	ns
$C_{PD}$	Power Dissipation Capacitance <sup>(4)</sup>			100		pF
$C_{IN}$	Input Capacitance			6		pF

- (1) Unless otherwise specified, min/max limits apply across the  $-40^\circ\text{C}$  to  $85^\circ\text{C}$  temperature range. All typicals are given for  $V_{CC} = 5V$  and  $T_A = 25^\circ\text{C}$ .
- (2) Skew is defined as the difference in propagation delays between complementary outputs at the 50% point.
- (3) Output disable time is the delay from the control input being switched to the output transistors turning off. The actual disable times are less than indicated due to the delay added by the RC time constant of the load.
- (4)  $C_{PD}$  determines the no load dynamic power consumption,  $P_D = C_{PD} V_{CC}^2 f + I_{CC} V_{CC}$ , and the no load dynamic current consumption,  $I_S = C_{PD} V_{CC} f + I_{CC}$ .

## Comparison Table of Switching Characteristics into “LS-Type” Load<sup>(1)</sup>

$V_{CC} = 5V$ ,  $T_A = +25^\circ\text{C}$ ,  $t_r \leq 6 \text{ ns}$ ,  $t_f \leq 6 \text{ ns}$  (Figure 6, Figure 7, Figure 8, Figure 9, Figure 10, Figure 11)

Parameter		Test Conditions	DS34C87		DS3487		Units
			Typ	Max	Typ	Max	
$t_{PLH}, t_{PHL}$	Propagation Delay Input to Output		6	10	10	15	ns
Skew	See <sup>(2)</sup>		1.5	2.0			ns
$t_{THL}, t_{TLH}$	Differential Output Rise and Fall Times		4	7	10	15	ns
$t_{PHZ}$	Output Disable Time See <sup>(3)</sup>	$C_L = 50 \text{ pF}$ , $R_L = 200\Omega$ , S1 Closed, S2 Closed	8	11	17	25	ns
$t_{PLZ}$	Output Disable Time See <sup>(3)</sup>	$C_L = 50 \text{ pF}$ , $R_L = 200\Omega$ , S1 Closed, S2 Closed	7	10	15	25	ns
$t_{PZH}$	Output Enable Time	$C_L = 50 \text{ pF}$ , $R_L = \infty$ , S1 Open, S2 Closed	11	19	11	25	ns
$t_{PZL}$	Output Enable Time	$C_L = 50 \text{ pF}$ , $R_L = 200\Omega$ , S1 Closed, S2 Open	14	21	15	25	ns

- (1) This table is provided for comparison purposes only. The values in this table for the DS34C87 reflect the performance of the device but are not tested or ensured.
- (2) Skew is defined as the difference in propagation delays between complementary outputs at the 50% point.
- (3) Output disable time is the delay from the control input being switched to the output transistors turning off. The actual disable times are less than indicated due to the delay added by the RC time constant of the load.

AC TEST CIRCUIT AND SWITCHING TIME WAVEFORMS

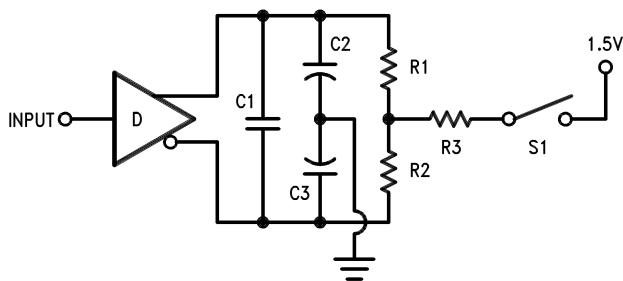

Note: C1 = C2 = C3 = 40 pF (including Probe and Jig Capacitance), R1 = R2 = 50Ω, R3 = 500Ω

Figure 3. AC Test Circuit

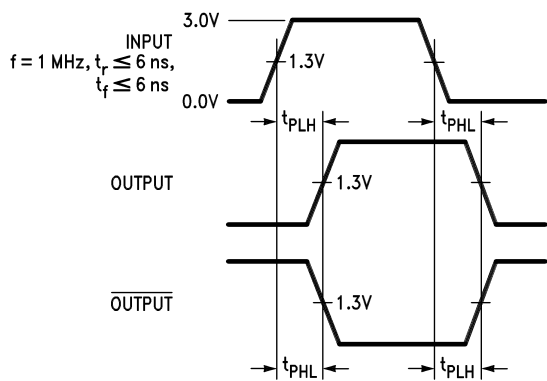

Figure 4. Propagation Delays

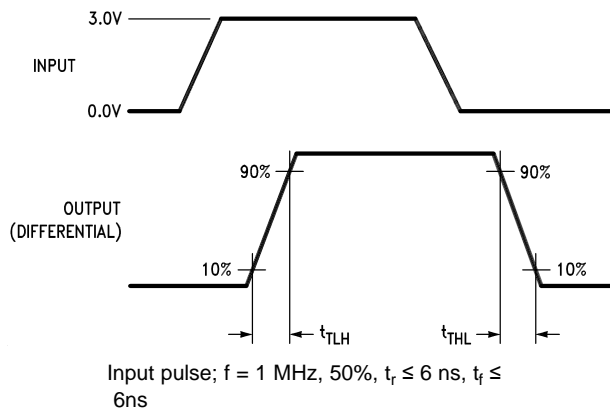

Figure 6. Differential Rise and Fall Times

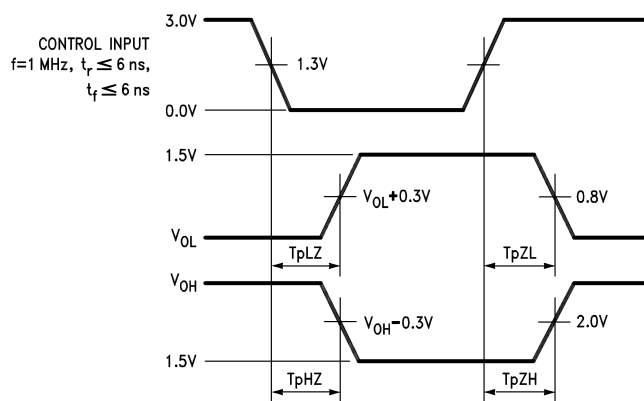

Figure 5. Enable and Disable Times

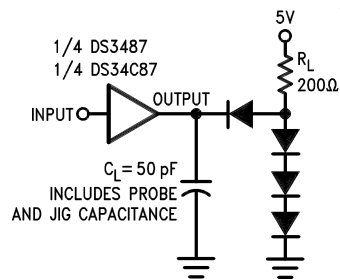

Figure 7. Propagation Delays Test Circuit for "LS-Type" Load

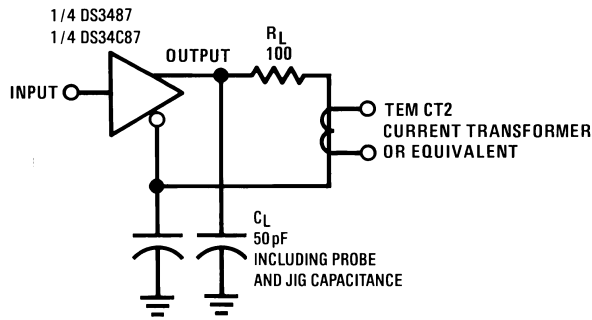

Figure 8. Differential Rise and Fall Times Test Circuit for "LS-Type" Load

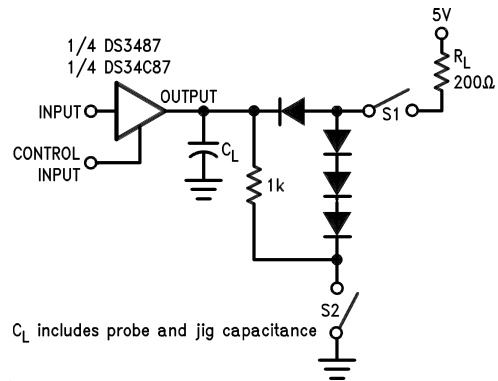

Figure 9. Load Enable and Disable Times Test Circuit for "LS-Type" Load

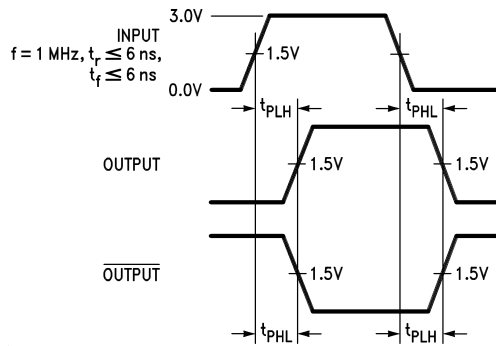

Figure 10. Load Propagation Delays for "LS-Type" Load

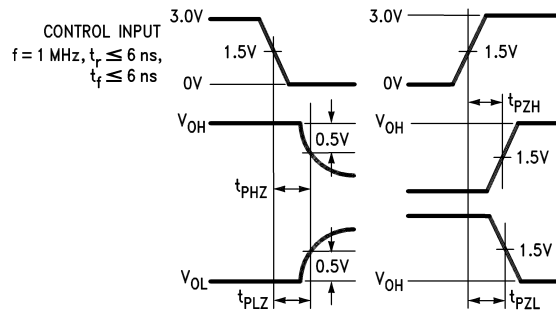
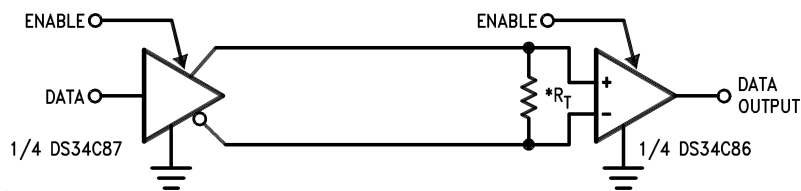

Figure 11. Load Enable and Disable Times for "LS-Type" Load

TYPICAL APPLICATIONS



\*RT is optional although highly recommended to reduce reflection.

**PIN DESCRIPTIONS**

Pin Number (PDIP or SOIC package)	Pin Name	Function
1	INPUT A	Channel A - TTL/CMOS input
2	OUTPUT A - True	True Output for Channel A, RS422 Levels
3	OUTPUT A - Inverting	Inverting Output for Channel A, RS422 Levels
4	A/B CONTROL	Enable Pin for Channels A and B, Active High, TTL/CMOS Levels
5	OUTPUT B - Inverting	Inverting Output for Channel B, RS422 Levels
6	OUTPUT B - True	True Output for Channel B, RS422 Levels
7	INPUT B	Channel B - TTL/CMOS input
8	GND	Ground Pin (0 V)
9	INPUT C	Channel C - TTL/CMOS input
10	OUTPUT C - True	True Output for Channel C, RS422 Levels
11	OUTPUT C - Inverting	Inverting Output for Channel C, RS422 Levels
12	C/D CONTROL	Enable Pin for Channels C and D, Active High, TTL/CMOS Levels
13	OUTPUT D - Inverting	Inverting Output for Channel D, RS422 Levels
14	OUTPUT D - True	True Output for Channel D, RS422 Levels
15	INPUT D	Channel D - TTL/CMOS input
16	V <sub>CC</sub>	Power Supply Pin, 5.0V typical

### REVISION HISTORY

Changes from Revision A (April 2013) to Revision B	Page
• Changed layout of National Data Sheet to TI format .....	<a href="#">7</a>

**PACKAGING INFORMATION**

Orderable Device	Status (1)	Package Type	Package Drawing	Pins	Package Qty	Eco Plan (2)	Lead finish/ Ball material (6)	MSL Peak Temp (3)	Op Temp (°C)	Device Marking (4/5)	Samples
DS34C87TM/NOPB	ACTIVE	SOIC	D	16	48	RoHS & Green	Call TI   SN	Level-1-260C-UNLIM	-40 to 85	DS34C87TM	<a href="#">Samples</a>
DS34C87TMX/NOPB	ACTIVE	SOIC	D	16	2500	RoHS & Green	SN	Level-1-260C-UNLIM	-40 to 85	DS34C87TM	<a href="#">Samples</a>

(1) The marketing status values are defined as follows:

**ACTIVE:** Product device recommended for new designs.

**LIFEBUY:** TI has announced that the device will be discontinued, and a lifetime-buy period is in effect.

**NRND:** Not recommended for new designs. Device is in production to support existing customers, but TI does not recommend using this part in a new design.

**PREVIEW:** Device has been announced but is not in production. Samples may or may not be available.

**OBSOLETE:** TI has discontinued the production of the device.

(2) **RoHS:** TI defines "RoHS" to mean semiconductor products that are compliant with the current EU RoHS requirements for all 10 RoHS substances, including the requirement that RoHS substance do not exceed 0.1% by weight in homogeneous materials. Where designed to be soldered at high temperatures, "RoHS" products are suitable for use in specified lead-free processes. TI may reference these types of products as "Pb-Free".

**RoHS Exempt:** TI defines "RoHS Exempt" to mean products that contain lead but are compliant with EU RoHS pursuant to a specific EU RoHS exemption.

**Green:** TI defines "Green" to mean the content of Chlorine (Cl) and Bromine (Br) based flame retardants meet JS709B low halogen requirements of <=1000ppm threshold. Antimony trioxide based flame retardants must also meet the <=1000ppm threshold requirement.

(3) MSL, Peak Temp. - The Moisture Sensitivity Level rating according to the JEDEC industry standard classifications, and peak solder temperature.

(4) There may be additional marking, which relates to the logo, the lot trace code information, or the environmental category on the device.

(5) Multiple Device Markings will be inside parentheses. Only one Device Marking contained in parentheses and separated by a "~" will appear on a device. If a line is indented then it is a continuation of the previous line and the two combined represent the entire Device Marking for that device.

(6) Lead finish/Ball material - Orderable Devices may have multiple material finish options. Finish options are separated by a vertical ruled line. Lead finish/Ball material values may wrap to two lines if the finish value exceeds the maximum column width.

**Important Information and Disclaimer:**The information provided on this page represents TI's knowledge and belief as of the date that it is provided. TI bases its knowledge and belief on information provided by third parties, and makes no representation or warranty as to the accuracy of such information. Efforts are underway to better integrate information from third parties. TI has taken and continues to take reasonable steps to provide representative and accurate information but may not have conducted destructive testing or chemical analysis on incoming materials and chemicals. TI and TI suppliers consider certain information to be proprietary, and thus CAS numbers and other limited information may not be available for release.

In no event shall TI's liability arising out of such information exceed the total purchase price of the TI part(s) at issue in this document sold by TI to Customer on an annual basis.

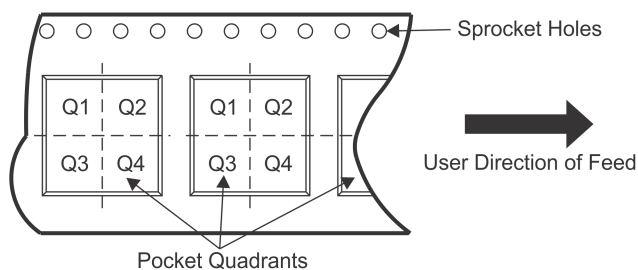

**TAPE AND REEL INFORMATION**

**QUADRANT ASSIGNMENTS FOR PIN 1 ORIENTATION IN TAPE**

\*All dimensions are nominal

Device	Package Type	Package Drawing	Pins	SPQ	Reel Diameter (mm)	Reel Width W1 (mm)	A0 (mm)	B0 (mm)	K0 (mm)	P1 (mm)	W (mm)	Pin1 Quadrant
DS34C87TMX/NOPB	SOIC	D	16	2500	330.0	16.4	6.5	10.3	2.3	8.0	16.0	Q1

**TAPE AND REEL BOX DIMENSIONS**

\*All dimensions are nominal

Device	Package Type	Package Drawing	Pins	SPQ	Length (mm)	Width (mm)	Height (mm)
DS34C87TMX/NOPB	SOIC	D	16	2500	356.0	356.0	35.0

**TUBE**

\*All dimensions are nominal

Device	Package Name	Package Type	Pins	SPQ	L (mm)	W (mm)	T (μm)	B (mm)
DS34C87TM/NOPB	D	SOIC	16	48	495	8	4064	3.05

D (R-PDSO-G16)

PLASTIC SMALL OUTLINE



- NOTES:
- A. All linear dimensions are in inches (millimeters).
  - B. This drawing is subject to change without notice.
  - C. Body length does not include mold flash, protrusions, or gate burrs. Mold flash, protrusions, or gate burrs shall not exceed 0.006 (0,15) each side.
  - D. Body width does not include interlead flash. Interlead flash shall not exceed 0.017 (0,43) each side.
  - E. Reference JEDEC MS-012 variation AC.

## IMPORTANT NOTICE AND DISCLAIMER

TI PROVIDES TECHNICAL AND RELIABILITY DATA (INCLUDING DATA SHEETS), DESIGN RESOURCES (INCLUDING REFERENCE DESIGNS), APPLICATION OR OTHER DESIGN ADVICE, WEB TOOLS, SAFETY INFORMATION, AND OTHER RESOURCES "AS IS" AND WITH ALL FAULTS, AND DISCLAIMS ALL WARRANTIES, EXPRESS AND IMPLIED, INCLUDING WITHOUT LIMITATION ANY IMPLIED WARRANTIES OF MERCHANTABILITY, FITNESS FOR A PARTICULAR PURPOSE OR NON-INFRINGEMENT OF THIRD PARTY INTELLECTUAL PROPERTY RIGHTS.

These resources are intended for skilled developers designing with TI products. You are solely responsible for (1) selecting the appropriate TI products for your application, (2) designing, validating and testing your application, and (3) ensuring your application meets applicable standards, and any other safety, security, regulatory or other requirements.

These resources are subject to change without notice. TI grants you permission to use these resources only for development of an application that uses the TI products described in the resource. Other reproduction and display of these resources is prohibited. No license is granted to any other TI intellectual property right or to any third party intellectual property right. TI disclaims responsibility for, and you will fully indemnify TI and its representatives against, any claims, damages, costs, losses, and liabilities arising out of your use of these resources.

TI's products are provided subject to [TI's Terms of Sale](#) or other applicable terms available either on [ti.com](http://ti.com) or provided in conjunction with such TI products. TI's provision of these resources does not expand or otherwise alter TI's applicable warranties or warranty disclaimers for TI products.

TI objects to and rejects any additional or different terms you may have proposed.

Mailing Address: Texas Instruments, Post Office Box 655303, Dallas, Texas 75265  
Copyright © 2022, Texas Instruments Incorporated