

Description

The IDT7130/IDT7140 are high-speed 1K x 8 Dual-Port Static RAMs. The IDT7130 is designed to be used as a stand-alone 8-bit Dual-Port RAM or as a "MASTER" Dual-Port RAM together with the IDT7140 "SLAVE" Dual-Port in 16-bit-or-more word width systems. Using the IDT MASTER/SLAVE Dual-Port RAM approach in 16-or-more-bit memory system applications results in full-speed, error-free operation without the need for additional discrete logic.

Both devices provide two independent ports with separate control, address, and I/O pins that permit independent asynchronous access for reads or writes to any location in memory. An automatic power down feature, controlled by \overline{CE} , permits the on chip circuitry

of each port to enter a very low standby power mode.

Fabricated using CMOS high-performance technology, these devices typically operate on only 550mW of power. Low-power (LA) versions offer battery backup data retention capability, with each Dual-Port typically consuming 200 μ W from a 2V battery.

The IDT7130/IDT7140 devices are packaged in 48-pin sidebraze or plastic DIPs, LCCs, flatpacks, 52-pin PLCC, and 64-pin TQFP and STQFP. Military grade products are manufactured in compliance with the latest revision of MIL-PRF-38535 QML, making it ideally suited to military temperature applications demanding the highest level of performance and reliability.

Pin Configurations^(1,2,3)

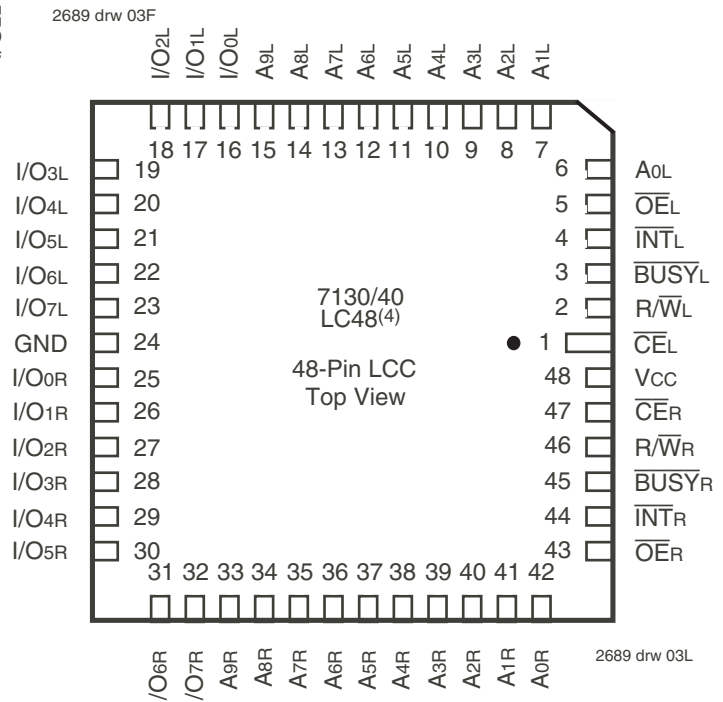
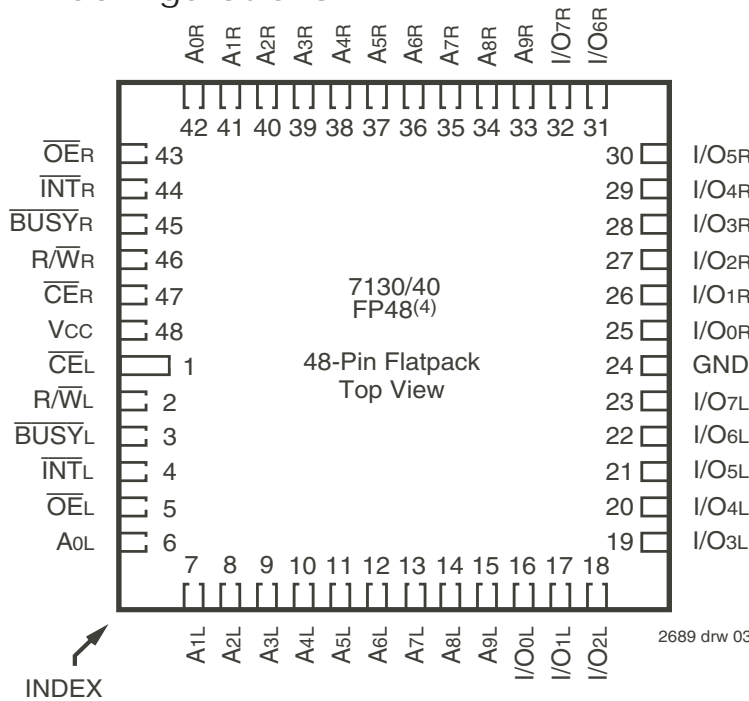

NOTES:

1. All Vcc pins must be connected to power supply.
2. All GND pins must be connected to ground supply.
3. LC48 package body is approximately .57 in x .57 in x .68 in.
FP48 package body is approximately .75 in x .75 in x .11 in.
4. This package code is used to reference the package diagram.

Pin Configurations^(1,2,3) (con't.)

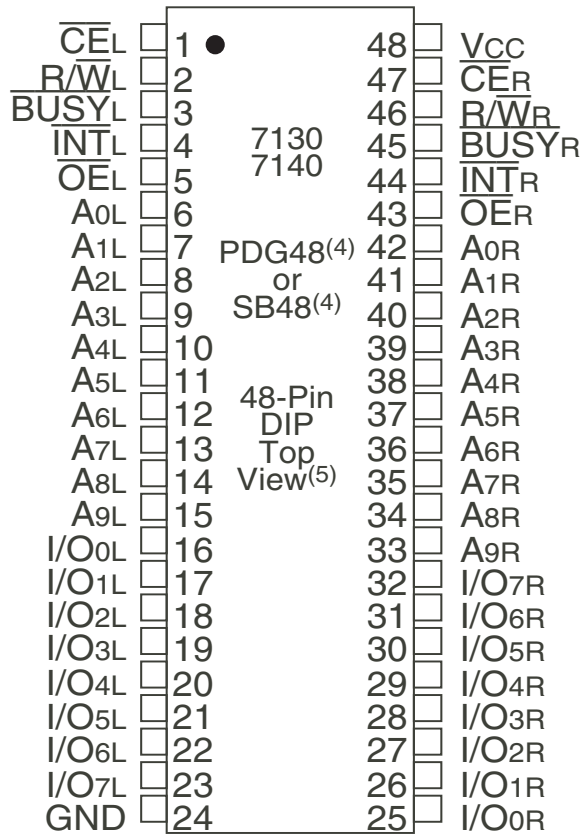

2689 drw 02

NOTES:

1. All Vcc pins must be connected to power supply.
2. All GND pins must be connected to ground supply.
3. PDG48 package body is approximately .55 in x .61 in x .19 in.
SB48 package body is approximately .62 in x 2.43 in x .15 in.
4. This package code is used to reference the package diagram.
5. This text does not indicate orientation of the actual part-marking.

Pin Configurations^(1,2,3) (con't.)

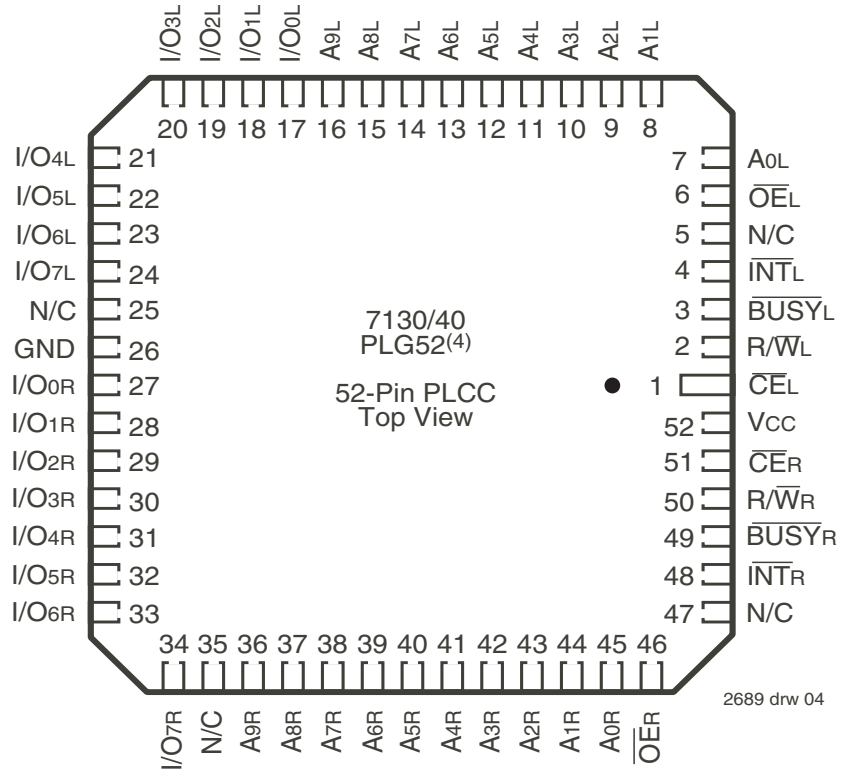

NOTES:

1. All Vcc pins must be connected to power supply.
2. All GND pins must be connected to ground supply.
3. PLG52 package body is approximately .75 in x .75 in x .17 in.
4. This package code is used to reference the package diagram.

Pin Configurations^(1,2,3) (con't.)

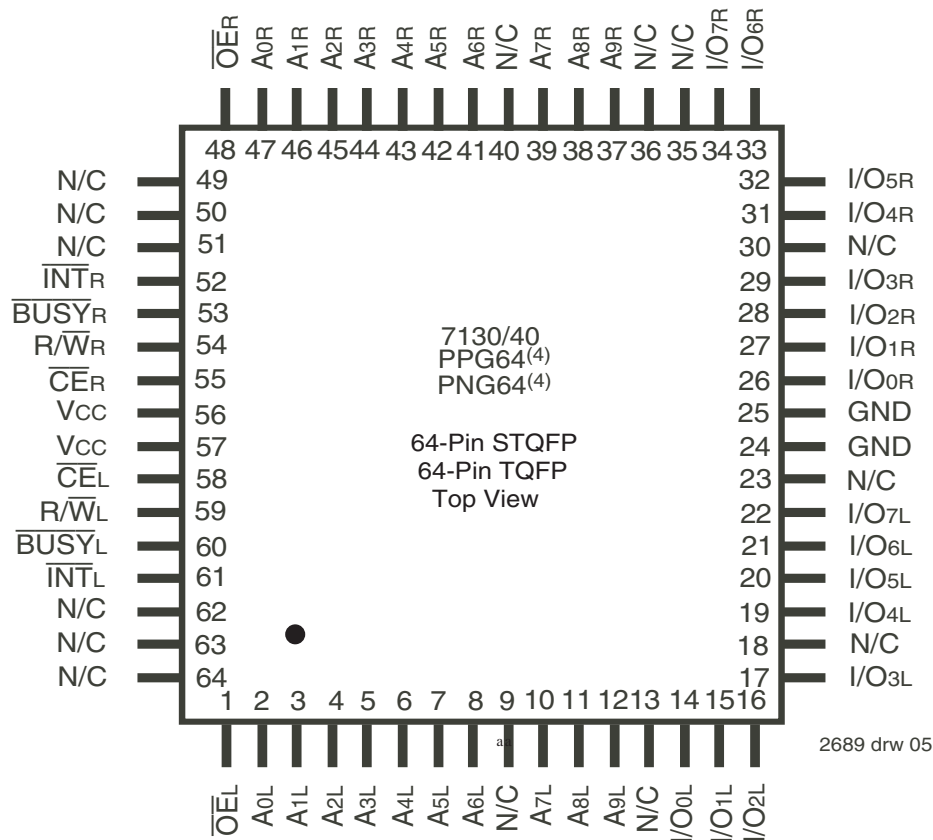

NOTES:

1. All Vcc pins must be connected to power supply.
2. All GND pins must be connected to ground supply.
3. PPG64 package body is approximately 10 mm x 10 mm x 1.4mm.
PNG64 package body is approximately 14mm x 14mm x 1.4mm.
4. This package code is used to reference the package diagram

Absolute Maximum Ratings⁽¹⁾

Symbol	Rating	Commercial & Industrial	Military	Unit
V _{TERM} ⁽²⁾	Terminal Voltage with Respect to GND	-0.5 to +7.0	-0.5 to +7.0	V
T _{BIAS}	Temperature Under Bias	-55 to +125	-65 to +135	°C
T _{STG}	Storage Temperature	-65 to +150	-65 to +150	°C
I _{OUT}	DC Output Current	50	50	mA

2689 tbl 01

NOTES:

- Stresses greater than those listed under ABSOLUTE MAXIMUM RATINGS may cause permanent damage to the device. This is a stress rating only and functional operation of the device at these or any other conditions above those indicated in the operational sections of the specification is not implied. Exposure to absolute maximum rating conditions for extended periods may affect reliability.
- V_{TERM} must not exceed V_{CC} + 10% for more than 25% of the cycle time or 10ns maximum, and is limited to ≤ 20mA for the period of V_{TERM} ≥ V_{CC} + 10%.

Capacitance (T_A = +25°C, f = 1.0MHz)

STQFP and TQFP Packages Only

Symbol	Parameter ⁽¹⁾	Conditions	Max.	Unit
C _{IN}	Input Capacitance	V _{IN} = 3dV	9	pF
C _{OUT}	Output Capacitance	V _{OUT} = 3dV	10	pF

2689 tbl 05

NOTES:

- This parameter is determined by device characterization but is not production tested.
- 3dV references the interpolated capacitance when the input and output signals switch from 0V to 3V or from 3V to 0V.

Recommended DC Operating Conditions

Symbol	Parameter	Min.	Typ.	Max.	Unit
V _{CC}	Supply Voltage	4.5	5.0	5.5	V
GND	Ground	0	0	0	V
V _{IH}	Input High Voltage	2.2	—	6.0 ⁽²⁾	V
V _{IL}	Input Low Voltage	-0.5 ⁽¹⁾	—	0.8	V

2689 tbl 02

NOTES:

- V_{IL} (min.) ≥ -1.5V for pulse width less than 10ns.
- V_{TERM} must not exceed V_{CC} + 10%.

Recommended Operating Temperature and Supply Voltage⁽¹⁾

Grade	Ambient Temperature	GND	V _{CC}
Military	-55°C to +125°C	0V	5.0V ± 10%
Commercial	0°C to +70°C	0V	5.0V ± 10%
Industrial	-40°C to +85°C	0V	5.0V ± 10%

2689 tbl 03

NOTES:

- This is the parameter T_A. This is the "instant on" case temperature.

DC Electrical Characteristics Over the Operating Temperature and Supply Voltage Range (V_{CC} = 5.0V ± 10%)

Symbol	Parameter	Test Conditions	7130SA 7140SA		7130LA 7140LA		Unit
			Min.	Max.	Min.	Max.	
I _L	Input Leakage Current ⁽¹⁾	V _{CC} = 5.5V, V _{IN} = 0V to V _{CC}	—	10	—	5	μA
I _O	Output Leakage Current ⁽¹⁾	V _{CC} = 5.5V, C _E = V _{IH} , V _{OUT} = 0V to V _{CC}	—	10	—	5	μA
V _{OL}	Output Low Voltage (I/O ₀ -I/O ₇)	I _{OL} = 4mA	—	0.4	—	0.4	V
V _{OL}	Open Drain Output Low Voltage (BUSY, INT)	I _{OL} = 16mA	—	0.5	—	0.5	V
V _{OH}	Output High Voltage	I _{OH} = -4mA	2.4	—	2.4	—	V

2689 tbl 04

NOTE:

- At V_{CC} ≤ 2.0V leakages are undefined.

DC Electrical Characteristics Over the Operating Temperature and Supply Voltage Range^(1,5) (V_{CC} = 5.0V ± 10%)

Symbol	Parameter	Test Condition	Version		7130X20 ⁽²⁾ 7140X20 ⁽²⁾ Com'l Only		7130X25 7140X25 Com'l, Ind & Military		7130X35 7140X35 Com'l & Military		Unit
					Typ.	Max.	Typ.	Max.	Typ.	Max.	
I _{CC}	Dynamic Operating Current (Both Ports - TTL Level Inputs)	\overline{CE}_L and $\overline{CE}_R = V_{IL}$, Outputs Disabled $f = f_{MAX}^{(3)}$	COM'L	SA	110	250	110	220	110	165	mA
				LA	110	200	110	170	110	120	
I _{SB1}	Standby Current (Both Ports - TTL Level Inputs)	\overline{CE}_L and $\overline{CE}_R = V_{IH}$ $f = f_{MAX}^{(3)}$	COM'L	SA	30	65	30	65	25	65	mA
				LA	30	45	30	45	25	45	
I _{SB2}	Standby Current (One Port - TTL Level Inputs)	$\overline{CE}^{A*} = V_{IL}$ and $\overline{CE}^{B*} = V_{IH}^{(6)}$ Active Port Outputs Disabled, $f = f_{MAX}^{(3)}$	COM'L	SA	65	165	65	150	50	125	mA
				LA	65	125	65	115	50	90	
I _{SB3}	Full Standby Current (Both Ports - CMOS Level Inputs)	\overline{CE}_L and $\overline{CE}_R \geq V_{CC} - 0.2V$, $V_{IN} \geq V_{CC} - 0.2V$ or $V_{IN} \leq 0.2V$, $f = 0^{(4)}$	COM'L	SA	1.0	15	1.0	15	1.0	30	mA
				LA	0.2	5	0.2	5	0.2	10	
I _{SB4}	Full Standby Current (One Port - CMOS Level Inputs)	$\overline{CE}^{A*} \leq 0.2V$ and $\overline{CE}^{B*} \geq V_{CC} - 0.2V^{(6)}$ $V_{IN} \geq V_{CC} - 0.2V$ or $V_{IN} \leq 0.2V$ Active Port Outputs Disabled, $f = f_{MAX}^{(3)}$	COM'L	SA	60	155	60	145	45	110	mA
				LA	60	115	60	105	45	85	
			MIL & IND	SA	—	—	110	280	110	230	
				LA	—	—	110	220	110	170	
			MIL & IND	SA	—	—	30	80	25	80	
				LA	—	—	30	60	25	60	
			MIL & IND	SA	—	—	65	160	50	150	
				LA	—	—	65	125	50	115	
			MIL & IND	SA	—	—	1.0	30	—	—	
				LA	—	—	0.2	10	—	—	
			MIL & IND	SA	—	—	60	155	45	110	
				LA	—	—	60	115	45	85	

2689 tbl 06a

Symbol	Parameter	Test Condition	Version		7130X55 7140X55 Com'l, Ind & Military		7130X100 7140X100 Com'l, Ind & Military		Unit
					Typ.	Max.	Typ.	Max.	
I _{CC}	Dynamic Operating Current (Both Ports Active)	\overline{CE}_L and $\overline{CE}_R = V_{IL}$, Outputs Disabled $f = f_{MAX}^{(3)}$	COM'L	SA	110	155	110	155	mA
				LA	110	110	110	110	
I _{SB1}	Standby Current (Both Ports - TTL Level Inputs)	\overline{CE}_L and $\overline{CE}_R = V_{IH}$ $f = f_{MAX}^{(3)}$	COM'L	SA	20	65	20	55	mA
				LA	20	35	20	35	
I _{SB2}	Standby Current (One Port - TTL Level Inputs)	$\overline{CE}^{A*} = V_{IL}$ and $\overline{CE}^{B*} = V_{IH}^{(6)}$ Active Port Outputs Disabled, $f = f_{MAX}^{(3)}$	COM'L	SA	40	110	40	110	mA
				LA	40	75	40	75	
I _{SB3}	Full Standby Current (Both Ports - CMOS Level Inputs)	\overline{CE}_L and $\overline{CE}_R \geq V_{CC} - 0.2V$, $V_{IN} \geq V_{CC} - 0.2V$ or $V_{IN} \leq 0.2V$, $f = 0^{(4)}$	COM'L	SA	1.0	15	1.0	15	mA
				LA	0.2	4	0.2	4	
I _{SB4}	Full Standby Current (One Port - CMOS Level Inputs)	$\overline{CE}^{A*} \leq 0.2V$ and $\overline{CE}^{B*} \geq V_{CC} - 0.2V^{(6)}$ $V_{IN} \geq V_{CC} - 0.2V$ or $V_{IN} \leq 0.2V$ Active Port Outputs Disabled, $f = f_{MAX}^{(3)}$	COM'L	SA	40	100	40	95	mA
				LA	40	70	40	70	
			MIL & IND	SA	110	190	110	190	
				LA	110	140	110	140	
			MIL & IND	SA	20	65	20	65	
				LA	20	35	20	35	
			MIL & IND	SA	40	125	40	125	
				LA	40	90	40	90	
			MIL & IND	SA	1.0	30	1.0	30	
				LA	0.2	10	0.2	10	
			MIL & IND	SA	40	100	40	95	
				LA	40	70	40	70	
			MIL & IND	SA	40	110	40	110	
				LA	40	85	40	80	

2689 tbl 06b

NOTES:

- 'X' in part numbers indicates power rating (SA or LA).
- PLCC, TQFP and STQFP packages only.
- At $f = f_{MAX}$, address and control lines (except Output Enable) are cycling at the maximum frequency read cycle of $1/t_{cvc}$, and using "AC TEST CONDITIONS" of input levels of GND to 3V.
- $f = 0$ means no address or control lines change. Applies only to inputs at CMOS level standby.
- V_{CC} = 5V, T_A = +25°C for Typ and is not production tested. V_{CC} DC = 100 mA (Typ)
- Port "A" may be either left or right port. Port "B" is opposite from port "A".

Data Retention Characteristics (LA Version Only)

Symbol	Parameter	Test Condition	7130LA/7140LA			Unit	
			Min.	Typ. ⁽¹⁾	Max.		
V _{DR}	V _{CC} for Data Retention		2.0	—	—	V	
I _{CDR}	Data Retention Current	V _{CC} = 2.0V, $\overline{CE} \geq V_{CC} - 0.2V$	MIL. & IND.	—	100	4000	μA
			COM'L.	—	100	1500	
t _{CDR} ⁽³⁾	Chip Deselect to Data Retention Time	V _{IN} ≥ V _{CC} - 0.2V or V _{IN} ≤ 0.2V	0	—	—	ns	
t _R ⁽³⁾	Operation Recovery Time		t _{RC} ⁽²⁾	—	—	ns	

2689 tbl 07

NOTES:

1. V_{CC} = 2V, T_A = +25°C, and is not production tested.
2. t_{RC} = Read Cycle Time
3. This parameter is guaranteed but not production tested.

Data Retention Waveform

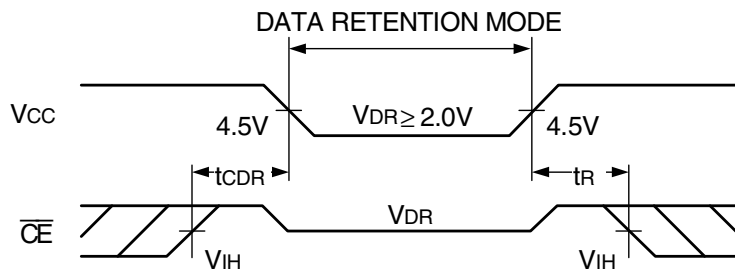

2692 drw 06

AC Test Conditions

Input Pulse Levels	GND to 3.0V
Input Rise/Fall Times	5ns
Input Timing Reference Levels	1.5V
Output Reference Levels	1.5V
Output Load	Figures 1,2 and 3

2689 tbl 08

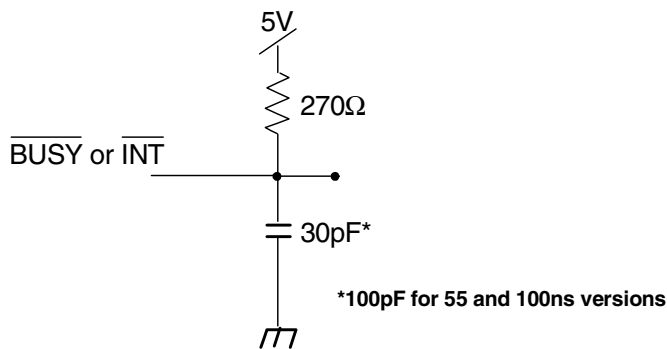
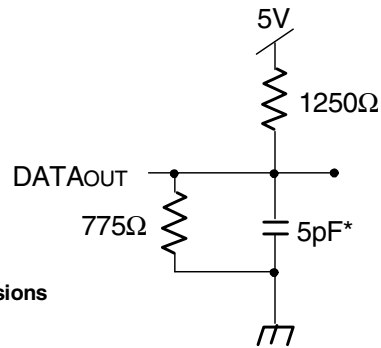
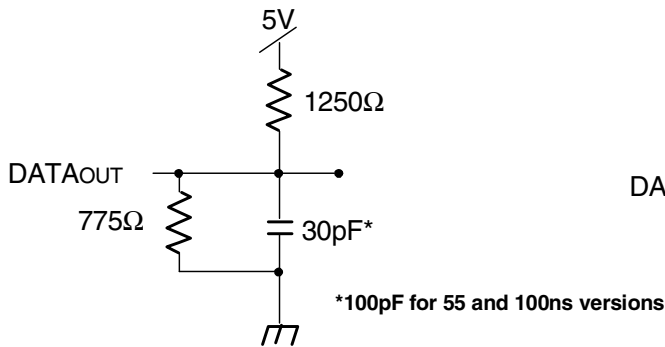

2689 drw 07

AC Electrical Characteristics Over the
Operating Temperature Supply Voltage Range⁽³⁾

Symbol	Parameter	7130X20 ⁽²⁾ 7140X20 ⁽²⁾ Com'l Only		7130X25 7140X25 Com'l, Ind & Military		7130X35 7140X35 Com'l & Military		Unit
		Min.	Max.	Min.	Max.	Min.	Max.	
READ CYCLE								
t _{RC}	Read Cycle Time	20	—	25	—	35	—	ns
t _{AA}	Address Access Time	—	20	—	25	—	35	ns
t _{ACE}	Chip Enable Access Time	—	20	—	25	—	35	ns
t _{AOE}	Output Enable Access Time	—	11	—	12	—	20	ns
t _{OH}	Output Hold from Address Change	3	—	3	—	3	—	ns
t _{LZ}	Output Low-Z Time ^(1,4)	0	—	0	—	0	—	ns
t _{HZ}	Output High-Z Time ^(1,4)	—	10	—	10	—	15	ns
t _{PU}	Chip Enable to Power Up Time ⁽⁴⁾	0	—	0	—	0	—	ns
t _{PD}	Chip Disable to Power Down Time ⁽⁴⁾	—	20	—	25	—	35	ns

2689 tbl 09a

Symbol	Parameter	7130X55 7140X55 Com'l, Ind & Military		7130X100 7140X100 Com'l, Ind & Military		Unit
		Min.	Max.	Min.	Max.	
READ CYCLE						
t _{RC}	Read Cycle Time	55	—	100	—	ns
t _{AA}	Address Access Time	—	55	—	100	ns
t _{ACE}	Chip Enable Access Time	—	55	—	100	ns
t _{AOE}	Output Enable Access Time	—	25	—	40	ns
t _{OH}	Output Hold from Address Change	3	—	10	—	ns
t _{LZ}	Output Low-Z Time ^(1,4)	5	—	5	—	ns
t _{HZ}	Output High-Z Time ^(1,4)	—	25	—	40	ns
t _{PU}	Chip Enable to Power Up Time ⁽⁴⁾	0	—	0	—	ns
t _{PD}	Chip Disable to Power Down Time ⁽⁴⁾	—	50	—	50	ns

2689 tbl 09b

NOTES:

1. Transition is measured 0mV from Low or High-impedance voltage Output Test Load (Figure 2).
2. PLCC, TQFP and STQFP packages only.
3. 'X' in part numbers indicates power rating (SA or LA).
4. This parameter is guaranteed by device characterization, but is not production tested.

Timing Waveform of Read Cycle No. 1, Either Side⁽¹⁾

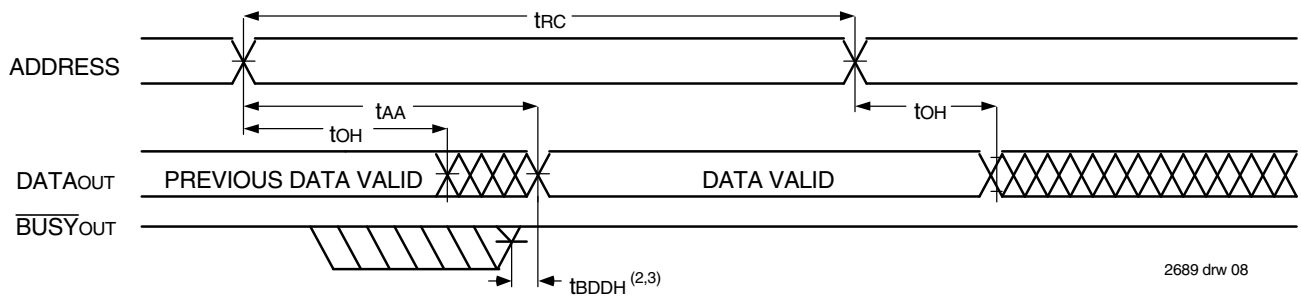

NOTES:

1. $R/\bar{W} = V_{IH}$, $\bar{CE} = V_{IL}$, and is $\bar{OE} = V_{IL}$. Address is valid prior to the coincidental with \bar{CE} transition LOW.
2. t_{BDH} delay is required only in the case where the opposite port is completing a write operation to the same the address location. For simultaneous read operations, \bar{BUSY} has no relationship to valid output data.
3. Start of valid data depends on which timing becomes effective last t_{AOE} , t_{ACE} , t_{AA} , and t_{BDH} .

Timing Waveform of Read Cycle No. 2, Either Side⁽³⁾

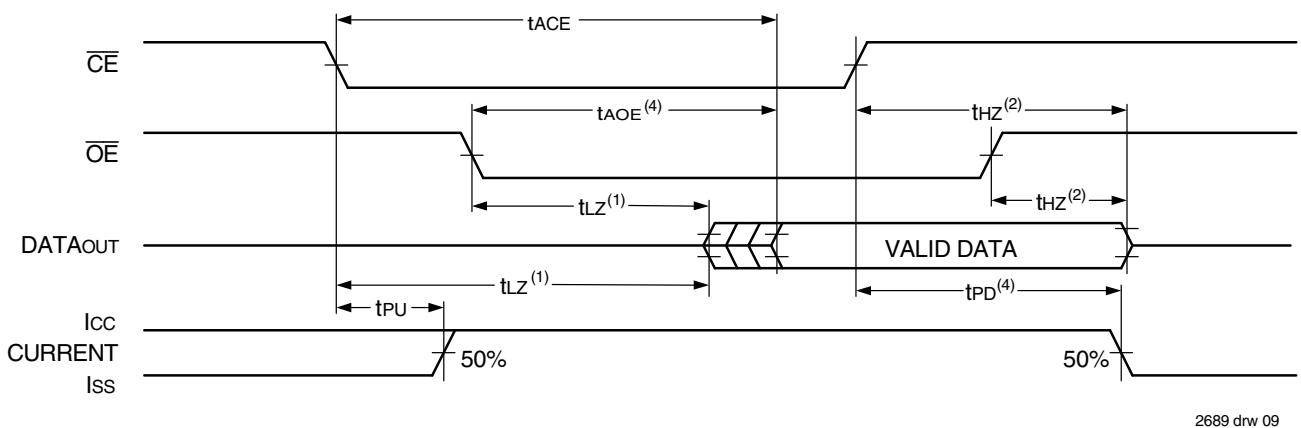

NOTES:

1. Timing depends on which signal is asserted last, \bar{OE} or \bar{CE} .
2. Timing depends on which signal is de-asserted first, \bar{OE} or \bar{CE} .
3. $R/\bar{W} = V_{IH}$ and $\bar{OE} = V_{IL}$, and the address is valid prior to or coincidental with \bar{CE} transition LOW.
4. Start of valid data depends on which timing becomes effective last t_{AOE} , t_{ACE} , t_{AA} , and t_{BDH} .

AC Electrical Characteristics Over the Operating Temperature Supply Voltage Range⁽⁵⁾

Symbol	Parameter	7130X20 ⁽²⁾ 7140X20 ⁽²⁾ Com'l Only		7130X25 7140X25 Com'l, Ind & Military		7130X35 7140X35 Com'l & Military		Unit
		Min.	Max.	Min.	Max.	Min.	Max.	
WRITE CYCLE								
t _{WC}	Write Cycle Time ⁽³⁾	20	—	25	—	35	—	ns
t _{EW}	Chip Enable to End-of-Write	15	—	20	—	30	—	ns
t _{AW}	Address Valid to End-of-Write	15	—	20	—	30	—	ns
t _{AS}	Address Set-up Time	0	—	0	—	0	—	ns
t _{WP}	Write Pulse Width ⁽⁴⁾	15	—	15	—	25	—	ns
t _{WR}	Write Recovery Time	0	—	0	—	0	—	ns
t _{DW}	Data Valid to End-of-Write	10	—	12	—	15	—	ns
t _{HZ}	Output High-Z Time ⁽¹⁾	—	10	—	10	—	15	ns
t _{DH}	Data Hold Time	0	—	0	—	0	—	ns
t _{WZ}	Write Enable to Output in High-Z ⁽¹⁾	—	10	—	10	—	15	ns
t _{OW}	Output Active from End-of-Write ⁽¹⁾	0	—	0	—	0	—	ns

2689 tbl 10a

Symbol	Parameter	7130X55 7140X55 Com'l, Ind & Military		7130X100 7140X100 Com'l, Ind & Military		Unit
		Min.	Max.	Min.	Max.	
WRITE CYCLE						
t _{WC}	Write Cycle Time ⁽³⁾	55	—	100	—	ns
t _{EW}	Chip Enable to End-of-Write	40	—	90	—	ns
t _{AW}	Address Valid to End-of-Write	40	—	90	—	ns
t _{AS}	Address Set-up Time	0	—	0	—	ns
t _{WP}	Write Pulse Width ⁽⁴⁾	30	—	55	—	ns
t _{WR}	Write Recovery Time	0	—	0	—	ns
t _{DW}	Data Valid to End-of-Write	20	—	40	—	ns
t _{HZ}	Output High-Z Time ⁽¹⁾	—	25	—	40	ns
t _{DH}	Data Hold Time	0	—	0	—	ns
t _{WZ}	Write Enable to Output in High-Z ⁽¹⁾	—	25	—	40	ns
t _{OW}	Output Active from End-of-Write ⁽¹⁾	0	—	0	—	ns

2689 tbl 10b

NOTES:

- Transition is measured 0mV from Low or High-impedance voltage with Output Test Load (Figure 2). This parameter is guaranteed by device characterization but is not production tested.
- PLCC, TQFP and STQFP packages only.
- For MASTER/SLAVE combination, t_{WC} = t_{BAA} + t_{WP}, since R \bar{W} = V_{IL} must occur after t_{BAA}.
- If \bar{OE} is LOW during a R \bar{W} controlled write cycle, the write pulse width must be the larger of t_{WP} or (t_{WZ} + t_{DW}) to allow the I/O drivers to turn off data to be placed on the bus for the required t_{DW}. If \bar{OE} is HIGH during a R \bar{W} controlled write cycle, this requirement does not apply and the write pulse can be as short as the specified t_{WP}.
- 'X' in part numbers indicates power rating (SA or LA).

Timing Waveform of Write Cycle No. 1, ($\overline{R/\overline{W}}$ Controlled Timing)^(1,5,8)

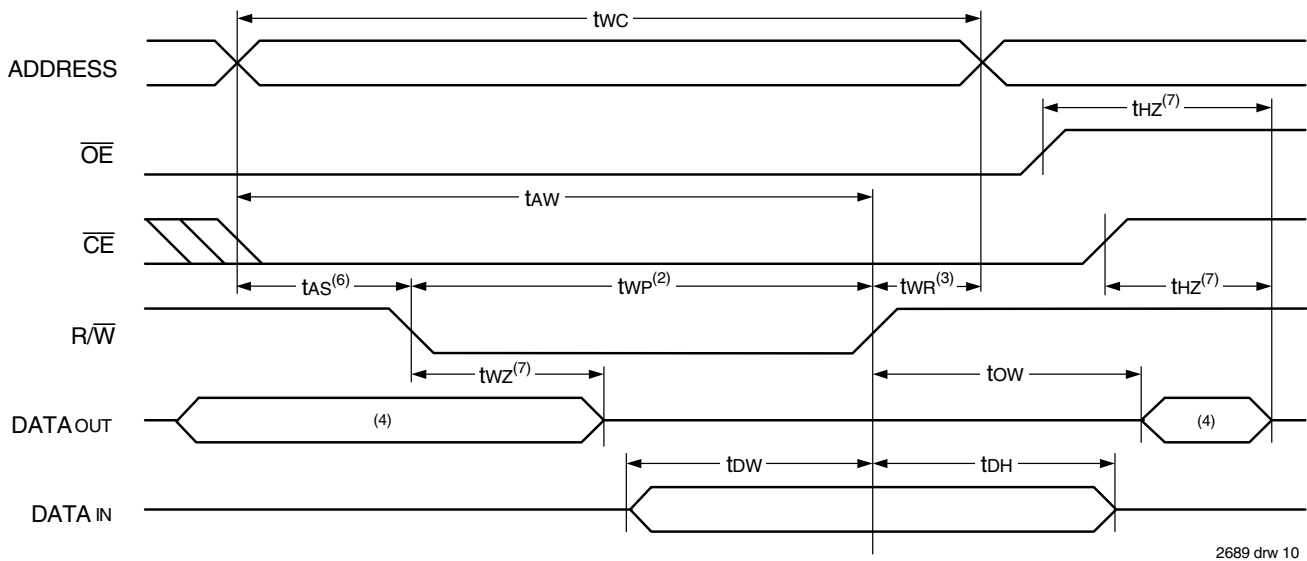

Timing Waveform of Write Cycle No. 2, (\overline{CE} Controlled Timing)^(1,5)

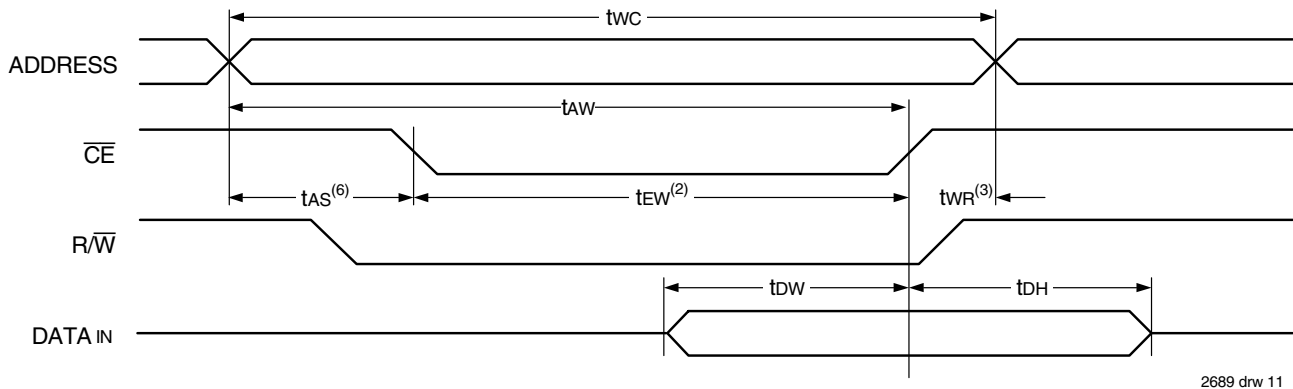

NOTES:

1. $\overline{R/\overline{W}}$ or \overline{CE} must be HIGH during all address transitions.
2. A write occurs during the overlap (t_{EW} or t_{WP}) of $\overline{CE} = V_{IL}$ and $\overline{R/\overline{W}} = V_{IL}$.
3. t_{WR} is measured from the earlier of \overline{CE} or $\overline{R/\overline{W}}$ going HIGH to the end of the write cycle.
4. During this period, the I/O pins are in the output state and input signals must not be applied.
5. If the \overline{CE} LOW transition occurs simultaneously with or after the $\overline{R/\overline{W}}$ LOW transition, the outputs remain in the HIGH impedance state.
6. Timing depends on which enable signal (\overline{CE} or $\overline{R/\overline{W}}$) is asserted last.
7. This parameter is determined by device characterization, but is not production tested. Transition is measured 0mV from steady state with the Output Test Load (Figure 2).
8. If \overline{OE} is LOW during a $\overline{R/\overline{W}}$ controlled write cycle, the write pulse width must be the larger of t_{WP} or ($t_{WZ} + t_{DW}$) to allow the I/O drivers to turn off data to be placed on the bus for the required t_{DW} . If \overline{OE} is HIGH during a $\overline{R/\overline{W}}$ controlled write cycle, this requirement does not apply and the write pulse can be as short as the specified t_{WP} .

AC Electrical Characteristics Over the Operating Temperature and Supply Voltage Range⁽⁷⁾

Symbol	Parameter	7130X20 ⁽¹⁾ 7140X20 ⁽¹⁾ Com'l Only		7130X25 7140X25 Com'l, Ind & Military		7130X35 7140X35 Com'l & Military		Unit
		Min.	Max.	Min.	Max.	Min.	Max.	
BUSY TIMING (For MASTER IDT 7130)								
tBAA	$\overline{\text{BUSY}}$ Access Time from Address	—	20	—	20	—	20	ns
tBDA	$\overline{\text{BUSY}}$ Disable Time from Address	—	20	—	20	—	20	ns
tBAC	$\overline{\text{BUSY}}$ Access Time from Chip Enable	—	20	—	20	—	20	ns
tBDC	$\overline{\text{BUSY}}$ Disable Time from Chip Enable	—	20	—	20	—	20	ns
tWH	Write Hold After $\overline{\text{BUSY}}$ ⁽⁶⁾	12	—	15	—	20	—	ns
tWDD	Write Pulse to Data Delay ⁽²⁾	—	40	—	50	—	60	ns
tDDD	Write Data Valid to Read Data Delay ⁽²⁾	—	30	—	35	—	35	ns
tAPS	Arbitration Priority Set-up Time ⁽³⁾	5	—	5	—	5	—	ns
tBDD	$\overline{\text{BUSY}}$ Disable to Valid Data ⁽⁴⁾	—	25	—	35	—	35	ns
BUSY INPUT TIMING (For SLAVE IDT 7140)								
tWB	Write to $\overline{\text{BUSY}}$ Input ⁽⁵⁾	0	—	0	—	0	—	ns
tWH	Write Hold After $\overline{\text{BUSY}}$ ⁽⁶⁾	12	—	15	—	20	—	ns
tWDD	Write Pulse to Data Delay ⁽²⁾	—	40	—	50	—	60	ns
tDDD	Write Data Valid to Read Data Delay ⁽²⁾	—	30	—	35	—	35	ns

2689 tbl 11a

Symbol	Parameter	7130X55 7140X55 Com'l, Ind & Military		7130X100 7140X100 Com'l, Ind & Military		Unit
		Min.	Max.	Min.	Max.	
BUSY TIMING (For MASTER IDT 7130)						
tBAA	$\overline{\text{BUSY}}$ Access Time from Address]	—	30	—	50	ns
tBDA	$\overline{\text{BUSY}}$ Disable Time from Address	—	30	—	50	ns
tBAC	$\overline{\text{BUSY}}$ Access Time from Chip Enable	—	30	—	50	ns
tBDC	$\overline{\text{BUSY}}$ Disable Time from Chip Enable	—	30	—	50	ns
tWH	Write Hold After $\overline{\text{BUSY}}$ ⁽⁶⁾	20	—	20	—	ns
tWDD	Write Pulse to Data Delay ⁽²⁾	—	80	—	120	ns
tDDD	Write Data Valid to Read Data Delay ⁽²⁾	—	55	—	100	ns
tAPS	Arbitration Priority Set-up Time ⁽³⁾	5	—	5	—	ns
tBDD	$\overline{\text{BUSY}}$ Disable to Valid Data ⁽⁴⁾	—	55	—	65	ns
BUSY INPUT TIMING (For SLAVE IDT 7140)						
tWB	Write to $\overline{\text{BUSY}}$ Input ⁽⁵⁾	0	—	0	—	ns
tWH	Write Hold After $\overline{\text{BUSY}}$ ⁽⁶⁾	20	—	20	—	ns
tWDD	Write Pulse to Data Delay ⁽²⁾	—	80	—	120	ns
tDDD	Write Data Valid to Read Data Delay ⁽²⁾	—	55	—	100	ns

2689 tbl 11b

NOTES:

1. PLCC, TOFP and STQFP packages only.
2. Port-to-port delay through RAM cells from the writing port to the reading port, refer to "Timing Waveform of Write with Port -to-Port Read and $\overline{\text{BUSY}}$."
3. To ensure that the earlier of the two ports wins.
4. tBDD is a calculated parameter and is the greater of 0, tWDD – tWP (actual) or tDDD – tW (actual).
5. To ensure that a write cycle is inhibited on port 'B' during contention on port 'A'.
6. To ensure that a write cycle is completed on port 'B' after contention on port 'A'.
7. 'X' in part numbers indicates power rating (S or L).

Timing Waveform of Write with Port-to-Port Read and **BUSY**^(2,3,4)

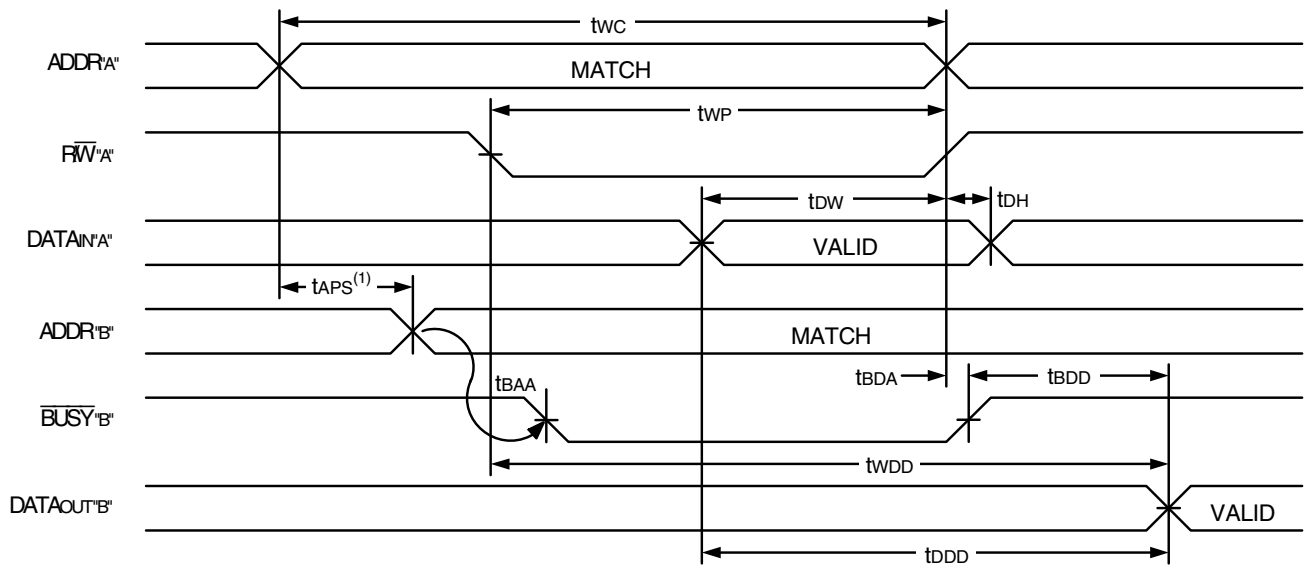

2689 drw 12

NOTES:

1. To ensure that the earlier of the two ports wins. t_{BDD} is ignored for slave (IDT7140).
2. $\overline{CE}_L = \overline{CE}_R = V_{IL}$
3. $\overline{OE} = V_{IL}$ for the reading port.
4. All timing is the same for the left and right ports. Port 'A' may be either the left or right port. Port 'B' is opposite from port 'A'.

Timing Waveform of Write with **BUSY**⁽³⁾

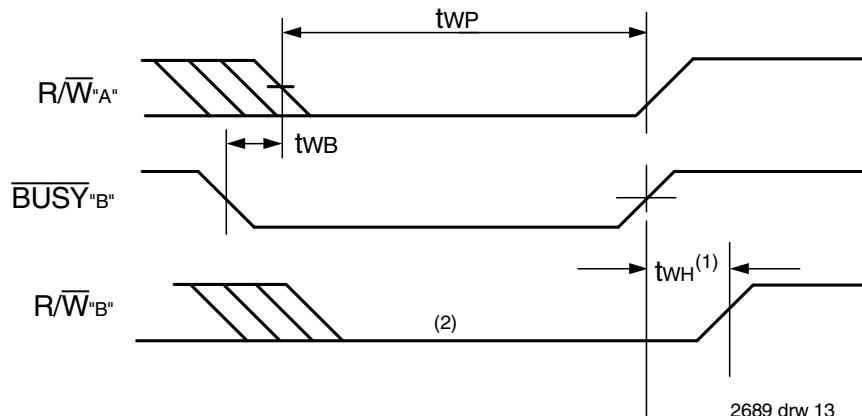

2689 drw 13

NOTES:

1. t_{WH} must be met for both BUSY Input (IDT7140, slave) or Output (IDT7130 master).
2. **BUSY** is asserted on port "B" blocking R/W'B', until **BUSY**'B' goes HIGH.
3. All timing is the same for the left and right ports. Port "A" may be either the left or right port. Port "B" is opposite from port "A".

Timing Waveform of **BUSY** Arbitration Controlled by **CE** Timing⁽¹⁾

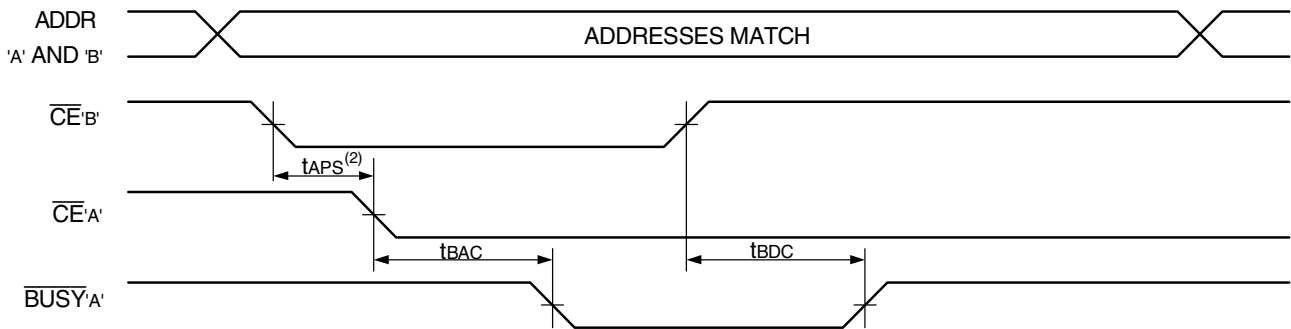

2689 drw 14

Timing Waveform by **BUSY** Arbitration Controlled by Address Match Timing⁽¹⁾

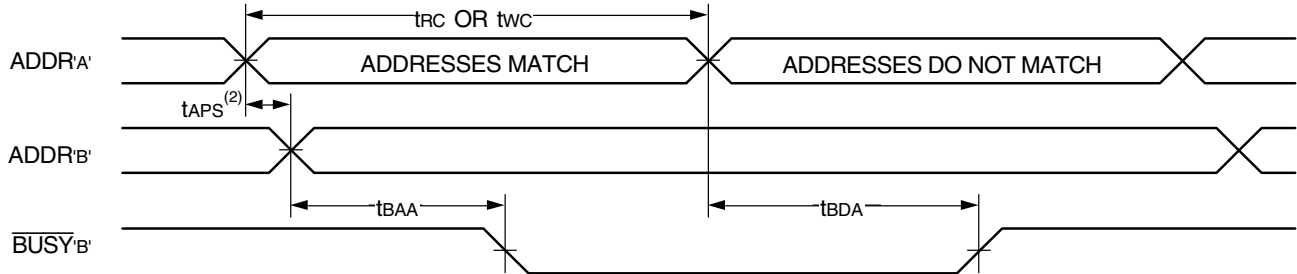

2689 drw 15

NOTES:

1. All timing is the same for left and right ports. Port "A" may be either left or right port. Port "B" is the opposite from port "A".
2. If tAPS is not satisfied, the **BUSY** will be asserted on one side or the other, but there is no guarantee on which side **BUSY** will be asserted (7130 only).

AC Electrical Characteristics Over the Operating Temperature and Supply Voltage Range⁽²⁾

Symbol	Parameter	7130X20 ⁽¹⁾ 7140X20 ⁽¹⁾ Com'l Only		7130X25 7140X25 Com'l, Ind & Military		7130X35 7140X35 Com'l & Military		Unit
		Min.	Max.	Min.	Max.	Min.	Max.	
INTERRUPT TIMING								
tAS	Address Set-up Time	0	—	0	—	0	—	ns
tWR	Write Recovery Time	0	—	0	—	0	—	ns
tINS	Interrupt Set Time	—	20	—	25	—	25	ns
tINR	Interrupt Reset Time	—	20	—	25	—	25	ns

2689 tbl 12a

NOTES:

1. PLCC, TOFP and STOFF package only.
2. 'X' in part numbers indicates power rating (SA or LA).

AC Electrical characteristics Over the Operating Temperature and Supply Voltage Range⁽¹⁾

Symbol	Parameter	7130X55 7140X55 Com'l, Ind & Military		7130X100 7140X100 Com'l, Ind & Military		Unit
		Min.	Max.	Min.	Max.	
INTERRUPT TIMING						
t _{AS}	Address Set-up Time	0	—	0	—	ns
t _{WR}	Write Recovery Time	0	—	0	—	ns
t _{INS}	Interrupt Set Time	—	45	—	60	ns
t _{INR}	Interrupt Reset Time	—	45	—	60	ns

2689 tbl 12b

NOTES:

- 'X' in part numbers indicates power rating (SA or LA).

Timing Waveform of Interrupt Mode⁽¹⁾

INT Set:

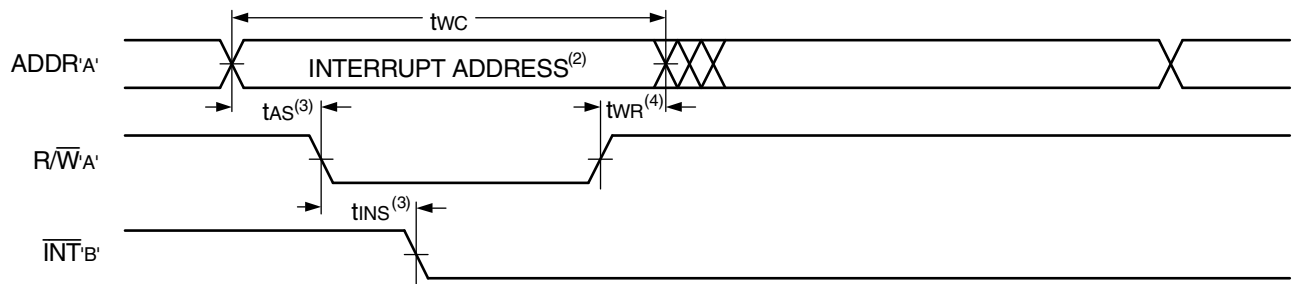

2689 drw 16

INT Clear:

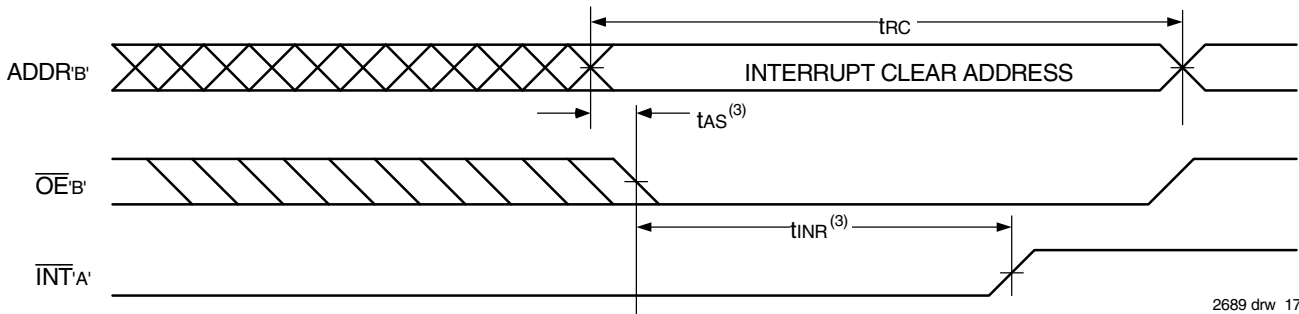

2689 drw 17

NOTES:

- All timing is the same for left and right ports. Port "A" may be either left or right port. Port "B" is the opposite from port "A".
- See Interrupt Truth Table II.
- Timing depends on which enable signal (\overline{CE} or R/\overline{W}) is asserted last.
- Timing depends on which enable signal (\overline{CE} or R/\overline{W}) is de-asserted first.

Truth Tables

Truth Table I — Non-Contention Read/Write Control⁽⁴⁾

Inputs ⁽¹⁾				Function
R/W	CE	OE	D0-7	
X	H	X	Z	Port Disabled and in Power-Down Mode, ISB2 or ISB4
X	H	X	Z	$\overline{CE}_R = \overline{CE}_L = V_{IH}$, Power-Down Mode, ISB1 or ISB3
L	L	X	DATA _{IN}	Data on Port Written into Memory ⁽²⁾
H	L	L	DATA _{OUT}	Data in Memory Output on Port ⁽³⁾
H	L	H	Z	High Impedance Outputs

2689 tbl 13

NOTES:

1. A0L – A10L ≠ A0R – A10R.
2. If $\overline{BUSY} = L$, data is not written.
3. If $\overline{BUSY} = L$, data may not be valid, see t_{WDD} and t_{DD} timing.
4. 'H' = V_{IH} , 'L' = V_{IL} , 'X' = DON'T CARE, 'Z' = HIGH IMPEDANCE

Truth Table II — Interrupt Flag^(1,4)

Left Port					Right Port					Function
R/WL	CEL	OEL	A9L-A0L	INTL	RWR	CEr	OEr	A9R-A0R	INTR	
L	L	X	3FF	X	X	X	X	X	L ⁽²⁾	Set Right \overline{INTR} Flag
X	X	X	X	X	X	L	L	3FF	H ⁽³⁾	Reset Right \overline{INTR} Flag
X	X	X	X	L ⁽³⁾	L	L	X	3FE	X	Set Left \overline{INTL} Flag
X	L	L	3FE	H ⁽²⁾	X	X	X	X	X	Reset Left \overline{INTL} Flag

2689 tbl 14

NOTES:

1. Assumes $\overline{BUSYL} = \overline{BUSYR} = V_{IH}$
2. If $\overline{BUSYL} = V_{IL}$, then No Change.
3. If $\overline{BUSYR} = V_{IL}$, then No Change.
4. 'H' = HIGH, 'L' = LOW, 'X' = DON'T CARE

Truth Table III — Address **BUSY** Arbitration

Inputs			Outputs		Function
CEL	CEr	A0L-A9L A0R-A9R	\overline{BUSYL} ⁽¹⁾	\overline{BUSYR} ⁽¹⁾	
X	X	NO MATCH	H	H	Normal
H	X	MATCH	H	H	Normal
X	H	MATCH	H	H	Normal
L	L	MATCH	(2)	(2)	Write Inhibit ⁽³⁾

2689 tbl 15

NOTES:

1. Pins \overline{BUSYL} and \overline{BUSYR} are both outputs for IDT7130 (master). Both are inputs for IDT7140 (slave). \overline{BUSYx} outputs on the IDT7130 are open drain, not push-pull outputs. On slaves the \overline{BUSYx} input internally inhibits writes.
2. 'L' if the inputs to the opposite port were stable prior to the address and enable inputs of this port. 'H' if the inputs to the opposite port became stable after the address and enable inputs of this port. If t_{APS} is not met, either \overline{BUSYL} or $\overline{BUSYR} = LOW$ will result. \overline{BUSYL} and \overline{BUSYR} outputs can not be LOW simultaneously.
3. Writes to the left port are internally ignored when \overline{BUSYL} outputs are driving LOW regardless of actual logic level on the pin. Writes to the right port are internally ignored when \overline{BUSYR} outputs are driving LOW regardless of actual logic level on the pin.

Functional Description

The IDT7130/IDT7140 provides two ports with separate control, address and I/O pins that permit independent access for reads or writes to any location in memory. The IDT7130/IDT7140 has an automatic power down feature controlled by \overline{CE} . The \overline{CE} controls on-chip power down circuitry that permits the respective port to go into a standby mode when not selected ($\overline{CE} = V_{IH}$). When a port is enabled, access to the entire memory array is permitted.

Interrupts

If the user chooses the interrupt function, a memory location (mail box or message center) is assigned to each port. The left port interrupt flag (\overline{INTL}) is asserted when the right port writes to memory location 3FE (HEX), where a write is defined as the $\overline{CE}_R = R/\overline{W}_R = V_{IL}$ per Truth Table II. The left port clears the interrupt by accessing address location 3FE when $\overline{CE}_L = \overline{OE}_L = V_{IL}$, R/\overline{W} is a "don't care". Likewise, the right port interrupt flag (\overline{INTR}) is asserted when the left port writes to memory location 3FF (HEX) and to clear the interrupt flag (\overline{INTR}), the right port must access the memory location 3FF. The message (8 bits) at 3FE or 3FF is user-defined, since it is an addressable SRAM location. If the interrupt function is not used, address locations 3FE and 3FF are not used as mail boxes, but as part of the random access memory. Refer to Truth Table II for the interrupt operation.

Busy Logic

Busy Logic provides a hardware indication that both ports of the RAM have accessed the same location at the same time. It also allows one of the two accesses to proceed and signals the other side that the RAM is "Busy". The \overline{BUSY} pin can then be used to stall the access until the operation on the other side is completed. If a write operation has been attempted from the side that receives a \overline{BUSY} indication, the write signal is gated internally to prevent the write from proceeding.

The use of \overline{BUSY} logic is not required or desirable for all applications. In some cases it may be useful to logically OR the \overline{BUSY} outputs together and use any \overline{BUSY} indication as an interrupt source to flag the event of an illegal or illogical operation. In slave mode the \overline{BUSY} pin operates solely as a write inhibit input pin. Normal operation can be programmed by tying the \overline{BUSY} pins HIGH. If desired, unintended write operations can be prevented to a port by tying the \overline{BUSY} pin for that port LOW.

The \overline{BUSY} outputs on the IDT7130 RAM (Master) are open drain type outputs and require open drain resistors to operate. If these

RAMs are being expanded in depth, then the \overline{BUSY} indication for the resulting array does not require the use of an external AND gate.

Width Expansion with Busy Logic Master/Slave Arrays

When expanding an RAM array in width while using busy logic, one master part is used to decide which side of the RAM array will receive a busy indication, and to output that indication. Any number of slaves to be addressed in the same address range as the master, use the busy signal as a write inhibit signal. Thus on the IDT7130/IDT7140 RAMs the \overline{BUSY} pin is an output if the part is Master (IDT7130), and the \overline{BUSY} pin is an input if the part is a Slave (IDT7140) as shown in Figure 3.

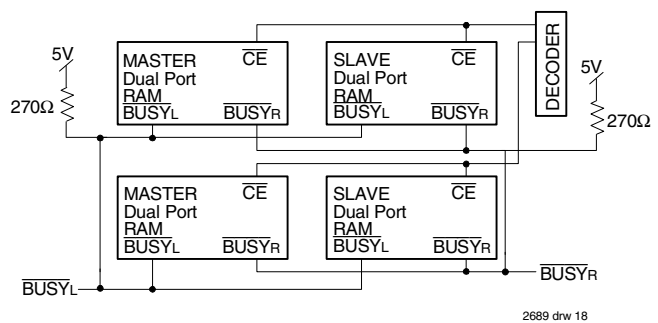
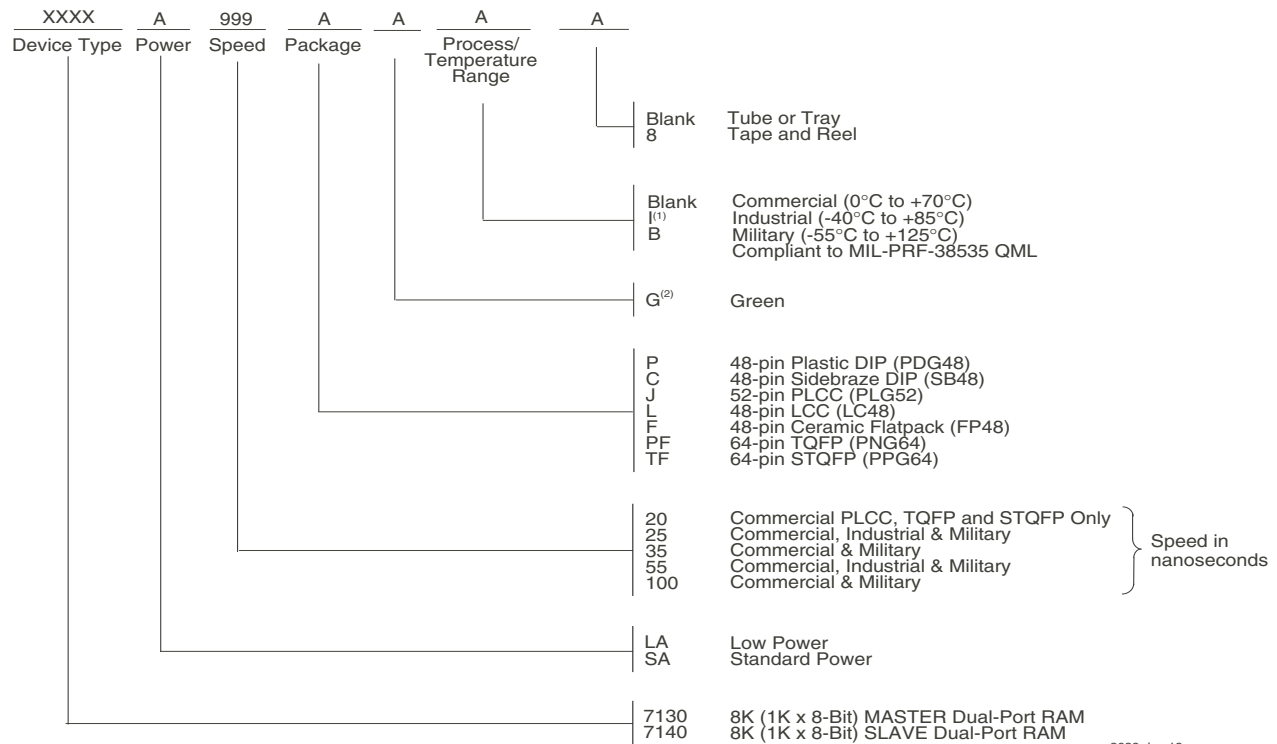

Figure 3. Busy and chip enable routing for both width and depth expansion with IDT7130 (Master) and IDT7140 (Slave) RAMs.

If two or more master parts were used when expanding in width, a split decision could result with one master indicating busy on one side of the array and another master indicating busy on one other side of the array. This would inhibit the write operations from one port for part of a word and inhibit the write operations from the other port for the other part of the word.

The \overline{BUSY} arbitration, on a Master, is based on the chip enable and address signals only. It ignores whether an access is a read or write. In a master/slave array, both address and chip enable must be valid long enough for a \overline{BUSY} flag to be output from the master before the actual write pulse can be initiated with either the R/\overline{W} signal or the byte enables. Failure to observe this timing can result in a glitched internal write inhibit signal and corrupted data in the slave.

Ordering Information



2689 drw 19

NOTES:

1. Contact your local sales office for industrial temperature range for other speeds, packages and powers.
2. Green parts available. For specific speeds, packages and powers contact your local sales office.

LEAD FINISH (SnPb) parts are Obsolete excluding FP48, LC48 & SB48. Product Discontinuation Notice - PDN# SP-17-02
Note that information regarding recently obsoleted parts are included in this datasheet for customer convenience.

Orderable Part Information

Speed (ns)	Orderable Part ID	Pkg. Code	Pkg. Type	Temp. Grade
20	7130LA20JG	PLG52	PLCC	C
	7130LA20JG8	PLG52	PLCC	C
	7130LA20PFG	PNG64	TQFP	C
	7130LA20PFG8	PNG64	TQFP	C
	7130LA20TFG	PPG64	STQFP	C
	7130LA20TFG8	PPG64	STQFP	C
25	7130LA25JGI	PLG52	PLCC	I
	7130LA25JGI8	PLG52	PLCC	I
	7130LA25L48B	LC48	LCC	M
	7130LA25PFGI	PNG64	TQFP	I
	7130LA25PFGI8	PNG64	TQFP	I
	7130LA25TFGI	PPG64	STQFP	I
35	7130LA35C	SB48	SB	C
	7130LA35CB	SB48	SB	M
	7130LA35FB	FP48	FPAK	M
	7130LA35L48B	LC48	LCC	M
	7130LA35PDG	PDG48	PDIP	C
55	7130LA55C	SB48	SB	C
	7130LA55CB	SB48	SB	M
	7130LA55FB	FP48	FPAK	M
	7130LA55L48B	LC48	LCC	M
	7130LA55PDGI	PDG48	PDIP	I
100	7130LA100C	SB48	SB	C
	7130LA100CB	SB48	SB	M
	7130LA100L48B	LC48	LCC	M
	7130LA100PDG	PDG48	PDIP	C

Speed (ns)	Orderable Part ID	Pkg. Code	Pkg. Type	Temp. Grade
20	7140LA20JG	PLG52	PLCC	C
	7140LA20JG8	PLG52	PLCC	C
25	7140LA25PFG	PNG64	TQFP	C
	7140LA25PFG8	PNG64	TQFP	C
35	7140LA35CB	SB48	SB	M
	7140LA35FB	FP48	FPAK	M
	7140LA35L48B	LC48	LCC	M
55	7140LA35PDG	PDG48	PDIP	C
	7140LA55CB	SB48	SB	M
100	7140LA55L48B	LC48	LCC	M
	7140LA100CB	SB48	SB	M
	7140LA100L48B	LC48	LCC	M
100	7140LA100PDG	PDG48	PDIP	C

Speed (ns)	Orderable Part ID	Pkg. Code	Pkg. Type	Temp. Grade
35	7140SA35CB	SB48	SB	M
	7140SA35L48B	LC48	LCC	M
55	7140SA55CB	SB48	SB	M
	7140SA55L48B	LC48	LCC	M
100	7140SA100CB	SB48	SB	M

Speed (ns)	Orderable Part ID	Pkg. Code	Pkg. Type	Temp. Grade
25	7130SA25L48B	LC48	LCC	M
35	7130SA35C	SB48	SB	C
	7130SA35CB	SB48	SB	M
	7130SA35L48B	LC48	LCC	M
55	7130SA55C	SB48	SB	C
	7130SA55CB	SB48	SB	M
	7130SA55L48B	LC48	LCC	M
100	7130SA100C	SB48	SB	C
	7130SA100CB	SB48	SB	M
	7130SA100L48B	LC48	LCC	M

Datasheet Document History

03/15/99:		Initiated datasheet document history Converted to new format Cosmetic and typographical corrections
	Pages 2 and 3	Added additional notes to pin configurations
06/08/99:		Changed drawing format
08/02/99:	Page 2	Corrected package number in note 3
09/29/99:	Page 2	Fixed pin 1 in DIP pin configuration
11/10/99:	Page 1 & 18	Replaced IDT logo
06/23/00:	Page 4	Increased storage temperature parameters Clarified TA parameter
	Page 5	DC Electrical parameters—changed wording from "open" to "disabled"
	Page 10	Changed $\pm 500\text{mV}$ to 0mV in notes
01/08/02:	Page 1	Added Ceramic Flatpack to 48-pin package offerings
	Page 2 & 3	Added date revision to pin configurations
	Page 4, 5, 8, 10, 12,14 & 15	Removed industrial temp option footnote from all tables
01/08/02:	Page 5, 8, 10, 12, & 14 Page 5, 8, 10, 12, & 14 Page 18	Added industrial temp for 25ns to DC & AC Electrical Characteristics Removed industrial temp for 35ns to DC & AC Electrical Characteristics Added industrial temp for 25ns and removed industrial temp for 35ns in ordering information Updated industrial temp option footnote
	Page 1 & 19	Replaced IDT TM logo with IDT [®] logo
01/11/06:	Page 1	Added green availability to features
	Page 18	Added green indicator to ordering information
	Page 1 & 19	Replaced old IDT TM with new IDT TM logo
04/14/06:	Page 18	Added "PDG" footnote to the ordering information
10/21/08:	Page 18	Removed "IDT" from orderable part number
01/21/13:	Page 2	Added L48-1 package and F48-1 package pin configurations with corresponding footnotes
	Page 13, 18, 19 & 20	Typo/corrections
	Page 20	Added T & Reel indicator to ordering information
05/20/16:	Page 2	Split the F48 and L48 pin configuration, creating two separate pin configurations: F48 pin ceramic flatpack rotated 90 degrees counterclockwise, removed footnote 5 reference and L48 LCC rotated 90 degrees clockwise to reflect pin 1 orientation and added dot at pin 1, removed footnote 5 reference
	Page 3	P48 plastic DIP and C48 sidebrazed DIP, removed half moon and to reflect pin 1 orientation added dot at pin 1
	Page 4	J52 PLCC rotated 90 degrees clockwise to reflect pin 1 orientation added dot at pin 1, removed footnote 5 reference
	Page 5	PN64 TQFP and PP64 STQFP, chamfer removed, rotated 90 degrees counterclockwise to reflect pin 1 orientation and added dot at pin 1, removed footnote 5 reference
	Page 20	All incidences of -1, -2 have been removed from the datasheet
02/13/18:		Product Discontinuation Notice - PDN# SP-17-02 Last time buy expires June 15, 2018
07/12/21:	Page 1 - 23 Page 1 & 21 Page 2, 3, 4 & 5 Page 21	Rebranded as Renesas datasheet Deleted obsolete Industrial speed grade for 100ns Updated package codes Added Orderable Part Information tables

IMPORTANT NOTICE AND DISCLAIMER

RENESAS ELECTRONICS CORPORATION AND ITS SUBSIDIARIES (“RENESAS”) PROVIDES TECHNICAL SPECIFICATIONS AND RELIABILITY DATA (INCLUDING DATASHEETS), DESIGN RESOURCES (INCLUDING REFERENCE DESIGNS), APPLICATION OR OTHER DESIGN ADVICE, WEB TOOLS, SAFETY INFORMATION, AND OTHER RESOURCES “AS IS” AND WITH ALL FAULTS, AND DISCLAIMS ALL WARRANTIES, EXPRESS OR IMPLIED, INCLUDING, WITHOUT LIMITATION, ANY IMPLIED WARRANTIES OF MERCHANTABILITY, FITNESS FOR A PARTICULAR PURPOSE, OR NON-INFRINGEMENT OF THIRD PARTY INTELLECTUAL PROPERTY RIGHTS.

These resources are intended for developers skilled in the art designing with Renesas products. You are solely responsible for (1) selecting the appropriate products for your application, (2) designing, validating, and testing your application, and (3) ensuring your application meets applicable standards, and any other safety, security, or other requirements. These resources are subject to change without notice. Renesas grants you permission to use these resources only for development of an application that uses Renesas products. Other reproduction or use of these resources is strictly prohibited. No license is granted to any other Renesas intellectual property or to any third party intellectual property. Renesas disclaims responsibility for, and you will fully indemnify Renesas and its representatives against, any claims, damages, costs, losses, or liabilities arising out of your use of these resources. Renesas' products are provided only subject to Renesas' Terms and Conditions of Sale or other applicable terms agreed to in writing. No use of any Renesas resources expands or otherwise alters any applicable warranties or warranty disclaimers for these products.

(Rev.1.0 Mar 2020)

Corporate Headquarters

TOYOSU FORESIA, 3-2-24 Toyosu,
Koto-ku, Tokyo 135-0061, Japan
www.renesas.com

Contact Information

For further information on a product, technology, the most up-to-date version of a document, or your nearest sales office, please visit:
www.renesas.com/contact/

Trademarks

Renesas and the Renesas logo are trademarks of Renesas Electronics Corporation. All trademarks and registered trademarks are the property of their respective owners.