

## SNx5LBC176 Differential Bus Transceivers

### 1 Features

- Bidirectional Transceiver
- Meets or Exceeds the Requirements of ANSI Standard TIA/EIA-485-A and ISO 8482:1987(E)
- High-Speed Low-Power LinBiCMOS™ Circuitry
- Designed for High-Speed Operation in Both Serial and Parallel Applications
- Low Skew
- Designed for Multipoint Transmission on Long Bus Lines in Noisy Environments
- Very Low Disabled Supply Current . . . 200  $\mu$ A Maximum
- Wide Positive and Negative Input/Output Bus Voltage Ranges
- Thermal-Shutdown Protection
- Driver Positive-and Negative-Current Limiting
- Open-Circuit Failsafe Receiver Design
- Receiver Input Sensitivity . . .  $\pm 200$  mV Max
- Receiver Input Hysteresis . . . 50 mV Typ
- Operates From a Single 5-V Supply
- Glitch-Free Power-Up and Power-Down Protection
- Available in Q-Temp Automotive HighRel Automotive Applications Configuration Control / Print Support Qualification to Automotive Standards

### 2 Description

The SN55LBC176, SN65LBC176, SN65LBC176Q, and SN75LBC176 differential bus transceivers are monolithic, integrated circuits designed for bidirectional data communication on multipoint bus-transmission lines. They are designed for balanced transmission lines and meet ANSI Standard TIA/EIA-485-A (RS-485) and ISO 8482:1987(E).

The SN55LBC176, SN65LBC176, SN65LBC176Q, and SN75LBC176 combine a 3-state, differential line driver and a differential input line receiver, both of which operate from a single 5-V power supply. The driver and receiver have active-high and active-low enables, respectively, which can externally connect together to function as a direction control. The driver differential outputs and the receiver differential inputs connect internally to form a differential input/output (I/O) bus port that is designed to offer minimum loading to the bus whenever the driver is disabled or  $V_{CC} = 0$ . This port features wide positive and negative common-mode voltage ranges, making the device suitable for party-line applications. Low device supply current can be achieved by disabling the driver and the receiver.

#### Package Information

PART NUMBER	PACKAGE <sup>(1)</sup>	BODY SIZE (NOM)
SN55LBC176	LCCC (20)	8.89 mm x 8.89 mm
	CDIP (8)	9.60 mm x 6.67 mm
SN65LBC176	SOIC (8)	4.90 mm x 3.91 mm
	PDIP (8)	9.81 mm x 6.35 mm
SN75LBC176	SOIC (8)	4.90 mm x 3.91 mm
	PDIP (8)	9.81 mm x 6.35 mm

(1) For all available packages, see the orderable addendum at the end of the data sheet.

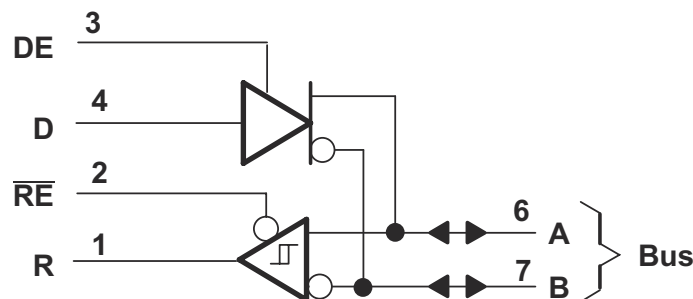

Figure 2-1. Logic Diagram (Positive Logic)



## Table of Contents

<b>1 Features</b> .....	1	6.8 Receiver Electrical Characteristics.....	8
<b>2 Description</b> .....	1	6.9 Receiver Switching Characteristics.....	8
<b>3 Revision History</b> .....	2	<b>7 Parameter Measurement Information</b> .....	9
<b>4 Description (Continued)</b> .....	3	<b>8 Detailed Description</b> .....	12
<b>5 Pin Configuration and Functions</b> .....	3	8.1 Functional Block Diagram.....	12
<b>6 Specifications</b> .....	4	8.2 Device Functional Modes.....	12
6.1 Absolute Maximum Ratings.....	4	<b>9 Device and Documentation Support</b> .....	14
6.2 Recommended Operating Conditions.....	4	9.1 Device Support.....	14
6.3 Thermal Information: SN55LBC176.....	4	9.2 Trademarks.....	14
6.4 Thermal Information: SN65LBC176, SN75LBC176....	5	9.3 Electrostatic Discharge Caution.....	15
6.5 Dissipation Ratings.....	5	9.4 Glossary.....	15
6.6 Driver Electrical Characteristics.....	5	<b>10 Mechanical, Packaging, and Orderable</b>	
6.7 Driver Switching Characteristics.....	7	<b>Information</b> .....	15

### 3 Revision History

NOTE: Page numbers for previous revisions may differ from page numbers in the current version.

<b>Changes from Revision H (December 2010) to Revision I (October 2022)</b>	<b>Page</b>
• Added <i>Pin Configuration and Functions</i> section, <i>Thermal Information</i> tables, <i>Detailed Description</i> section, <i>Device Functional Modes</i> , <i>Device and Documentation Support</i> section, and <i>Mechanical, Packaging, and Orderable Information</i> section .....	1

## 4 Description (Continued)

These transceivers are suitable for ANSI Standard TIA/EIA-485 (RS-485) and ISO 8482 applications to the extent that they are specified in the operating conditions and characteristics section of this data sheet. Certain limits contained in TIA/EIA-485-A and ISO 8482:1987 (E) are not met or cannot be tested over the entire military temperature range.

The SN55LBC176 is characterized for operation from  $-55^{\circ}\text{C}$  to  $125^{\circ}\text{C}$ . The SN65LBC176 is characterized for operation from  $-40^{\circ}\text{C}$  to  $85^{\circ}\text{C}$ , and the SN65LBC176Q is characterized for operation from  $-40^{\circ}\text{C}$  to  $125^{\circ}\text{C}$ . The SN75LBC176 is characterized for operation from  $0^{\circ}\text{C}$  to  $70^{\circ}\text{C}$ .

## 5 Pin Configuration and Functions

**D, JG, OR P PACKAGE  
(TOP VIEW)**

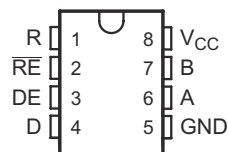

**FK PACKAGE  
(TOP VIEW)**

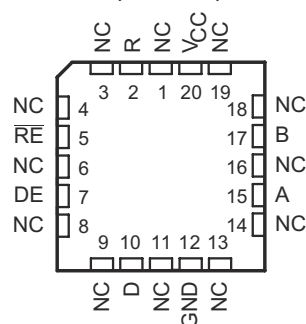

NC – No internal connection

**Table 5-1. Pin Functions**

NAME	PIN		TYPE	DESCRIPTION
	SOIC, PDIP, CDIP	LCCC		
R	1	2	O	Logic output RS485 data
RE	2	5	I	Receiver enable/disable
DE	3	7	I	Driver enable/disable
D	4	10	I	Logic input RS485 data
GND	5	12	-	Ground
A	6	15	I/O	RS485 bus pin; Non-Inverting
B	7	17	I/O	RS485 bus pin; Inverted
V <sub>CC</sub>	8	20	-	5V Supply Voltage
NC	-	1,2,3,6,8,9,11,13,14,16,18,19	-	No Internal Connection

## 6 Specifications

### 6.1 Absolute Maximum Ratings

over operating free-air temperature range (unless otherwise noted) <sup>(1)</sup>

	MIN	MAX	UNIT
Supply voltage, $V_{CC}$ <sup>(2)</sup>		7	V
Voltage range at any bus terminal	-10	15	V
Input voltage, $V_I$ (D, DE, R, or $\overline{RE}$ )	-0.3	$V_{CC} + 0.5$	V
Receiver output current, $I_O$	-10	10	mA
Continuous total power dissipation	See <a href="#">Section 6.5</a>		
Storage temperature range, $T_{stg}$	-65	150	°C

- (1) Stresses beyond those listed under Absolute Maximum Ratings may cause permanent damage to the device. These are stress ratings only, and functional operation of the device at these or any other conditions beyond those indicated under [Section 6.2](#) is not implied. Exposure to absolute-maximum-rated conditions for extended periods may affect device reliability.
- (2) All voltage values, except differential I/O bus voltage, are with respect to network ground terminal.

### 6.2 Recommended Operating Conditions

over operating free-air temperature range (unless otherwise noted)

		MIN	NOM	MAX	UNIT
Supply voltage, $V_{CC}$		4.75	5	5.25	V
Voltage at any bus terminal (separately or common mode), $V_I$ or $V_{IC}$		-7		12	V
High-level input voltage, $V_{IH}$	D, DE, and $\overline{RE}$	2			V
Low-level input voltage, $V_{IL}$	D, DE, and $\overline{RE}$			0.8	V
Differential input voltage, $V_{ID}$ <sup>(1)</sup>		-12		12	V
High-level output current, $I_{OH}$	Driver	-60			mA
	Receiver	-400			μA
Low-level output current, $I_{OL}$	Driver			60	mA
	Receiver			8	mA
Junction temperature, $T_J$				140	°C
Operating free-air temperature, $T_A$	SN55LBC176	-55		125	°C
	SN65LBC176	-40		85	
	SN65LBC176Q	-40		125	
	SN75LBC176	0		70	

- (1) Differential input/output bus voltage is measured at the noninverting terminal A with respect to the inverting terminal B.

### 6.3 Thermal Information: SN55LBC176

THERMAL METRIC <sup>(1)</sup>		FK	JG	UNIT
		20 PINS	8 PINS	
$R_{\theta JA}$	Junction-to-ambient thermal resistance	61.6	99.5	°C/W
$R_{\theta JC(top)}$	Junction-to-case (top) thermal resistance	36.8	51.5	
$R_{\theta JB}$	Junction-to-board thermal resistance	36.1	86.5	
$\Psi_{JT}$	Junction-to-top characterization parameter	31.0	23.7	
$\Psi_{JB}$	Junction-to-board characterization parameter	36.0	80.2	
$R_{\theta JC(bot)}$	Junction-to-case (bottom) thermal resistance	4.2	11.6	

## 6.4 Thermal Information: SN65LBC176, SN75LBC176

THERMAL METRIC <sup>(1)</sup>		D	P	UNIT
		8 PINS		
R <sub>θJA</sub>	Junction-to-ambient thermal resistance	116.7	65.6	°C/W
R <sub>θJC(top)</sub>	Junction-to-case (top) thermal resistance	56.3	54.6	
R <sub>θJB</sub>	Junction-to-board thermal resistance	63.4	42.1	
Ψ <sub>JT</sub>	Junction-to-top characterization parameter	8.8	22.9	
Ψ <sub>JB</sub>	Junction-to-board characterization parameter	62.6	41.6	
R <sub>θJC(bot)</sub>	Junction-to-case (bottom) thermal resistance	n/a	n/a	

(1) For more information about traditional and new thermal metrics, see the *IC Package Thermal Metrics* application report, [SPRA953](#).

## 6.5 Dissipation Ratings

PACKAGE	THERMAL MODEL	T <sub>A</sub> < 25°C POWER RATING	DERATING FACTOR ABOVE T <sub>A</sub> = 25°C	T <sub>A</sub> = 70°C POWER RATING	T <sub>A</sub> = 85°C POWER RATING	T <sub>A</sub> = 110°C POWER RATING
D	Low K <sup>(1)</sup>	526 mW	5.0 mW/°C	301 mW	226 mW	—
	High K <sup>(2)</sup>	882 mW	8.4 mW/°C	504 mW	378 mW	—
P		840 mW	8.0 mW/°C	480 mW	360 mW	—
JG		1050 mW	8.4 mW/°C	672 mW	546 mW	210 mW
FK		1375 mW	11.0 mW/°C	880 mW	715 mW	440 mW

(1) In accordance with the low effective thermal conductivity metric definitions of EIA/JESD 51–3.

(2) In accordance with the high effective thermal conductivity metric definitions of EIA/JESD 51–7.

## 6.6 Driver Electrical Characteristics

over recommended ranges of supply voltage and operating free-air temperature (unless otherwise noted)

PARAMETER		TEST CONDITIONS		MIN	MAX	UNIT
V <sub>IK</sub>	Input clamp voltage	I <sub>I</sub> = –18 mA		–1.5		V
V <sub>O</sub>	Output voltage	I <sub>O</sub> = 0		0	6	V
V <sub>OD1</sub>	Differential output voltage	I <sub>O</sub> = 0		1.5	6	V
V <sub>OD2</sub>	Differential output voltage	R <sub>L</sub> = 54 Ω, See (2)	See Figure 7-1, 55LBC176, 65LBC176, 65LBC176Q	1.1		V
				1.5	5	
V <sub>OD3</sub>	Differential output voltage	V <sub>test</sub> = –7 V to 12 V, See (2)	See Figure 2, 55LBC176, 65LBC176, 65LBC176Q	1.1		V
				1.5	5	
Δ V <sub>OD</sub>	Change in magnitude of differential output voltage (1)	R <sub>L</sub> = 54 Ω or 100 Ω, See Figure 7-1		–0.2	0.2	V
V <sub>OC</sub>	Common-mode output voltage			–1	3	V
Δ V <sub>OC</sub>	Change in magnitude of common-mode output voltage (1)			–0.2	0.2	V
I <sub>O</sub>	Output current	Output disabled, See (3)	V <sub>O</sub> = 12 V		1	mA
			V <sub>O</sub> = –7 V	–0.8		
I <sub>IH</sub>	High-level input current	V <sub>I</sub> = 2.4 V		–100		μA
I <sub>IL</sub>	Low-level input current	V <sub>I</sub> = 0.4 V		–100		μA

## 6.6 Driver Electrical Characteristics (continued)

over recommended ranges of supply voltage and operating free-air temperature (unless otherwise noted)

PARAMETER		TEST CONDITIONS		MIN	MAX	UNIT
I <sub>OS</sub>	Short circuit output current	V <sub>O</sub> = -7 V		-250		mA
		V <sub>O</sub> = 0		-150		
		V <sub>O</sub> = V <sub>CC</sub>			250	
		V <sub>O</sub> = 12 V				
I <sub>CC</sub>	Supply current	V <sub>I</sub> = 0 or V <sub>CC</sub> , No load	Receiver disabled and driver enabled	55LBC176, 65LBC176Q	1.75	mA
				65LBC176, 75LBC176	1.5	
			Receiver and driver disabled	55LBC176, 65LBC176Q	0.25	
				65LBC176, 75LBC176	0.2	

- (1)  $\Delta|V_{OD}|$  and  $\Delta|V_{OC}|$  are the changes in magnitude of V<sub>OD</sub> and V<sub>OC</sub>, respectively, that occur when the input changes from a high level to a low level.
- (2) This device meets the V<sub>OD</sub> requirements of TIA/EIA-485-A above 0°C only.
- (3) This applies for both power on and off; refer to TIA/EIA-485-A for exact conditions.

## 6.7 Driver Switching Characteristics

over recommended ranges of supply voltage and operating free-air temperature

PARAMETER	TEST CONDITIONS	SN55LBC176 SN65LBC176Q			SN65LBC176 SN75LBC176			UNIT
		MIN	TYP	MAX	MIN	TYP <sup>(1)</sup>	MAX	
$t_{d(OD)}$	Differential output delay time	$R_L = 54 \Omega$ , See <a href="#">Figure 7-3</a>	$C_L = 50 \text{ pF}$	8	31	8	25	ns
$t_{t(OD)}$	Differential output transition time			12	12	ns		
$t_{sk(p)}$	Pulse skew ( $ t_{d(ODH)} - t_{d(ODL)} $ )			6	0	6	ns	
$t_{PZH}$	Output enable time to high level	$R_L = 110 \Omega$	See <a href="#">Figure 7-4</a>	65		35	ns	
$t_{PZL}$	Output enable time to low level	$R_L = 110 \Omega$	See <a href="#">Figure 7-5</a>	65		35	ns	
$t_{PHZ}$	Output disable time from high level	$R_L = 110 \Omega$	See <a href="#">Figure 7-4</a>	105		60	ns	
$t_{PLZ}$	Output disable time from low level	$R_L = 110 \Omega$	See <a href="#">Figure 7-5</a>	105		35	ns	

(1) All typical values are at  $V_{CC} = 5 \text{ V}$ ,  $T_A = 25^\circ\text{C}$ .

**Table 6-1. Driver Symbol Equivalents**

DATA SHEET PARAMETER	RS-485
$V_O$	$V_{oa}, V_{ob}$
$ V_{OD1} $	$V_o$
$ V_{OD2} $	$V_t (R_L = 54 \Omega)$
$ V_{OD} $	$V_t$ (test termination measurement 2)
$\Delta  V_{OD} $	$  V_t  -  \bar{V}_t  $
$V_{OC}$	$ V_{os} $
$\Delta  V_{OC} $	$ V_{os} - \bar{V}_{os} $
$I_{OS}$	None
$I_O$	$I_{ia}, I_{ib}$

## 6.8 Receiver Electrical Characteristics

over recommended ranges of common-mode input voltage, supply voltage, and operating free-air temperature (unless otherwise noted)

PARAMETER		TEST CONDITIONS		MIN	TYP <sup>(1)</sup>	MAX	UNIT
V <sub>IT+</sub>	Positive-going input threshold voltage	V <sub>O</sub> = 2.7 V,	I <sub>O</sub> = -0.4 mA			0.2	V
V <sub>IT-</sub>	Negative-going input threshold voltage	V <sub>O</sub> = 0.5 V,	I <sub>O</sub> = 8 mA	-0.2 <sup>(2)</sup>			V
V <sub>hys</sub>	Hysteresis voltage (V <sub>IT+</sub> - V <sub>IT-</sub> ) (see Figure 7-4)				50		mV
V <sub>IK</sub>	Enable-input clamp voltage	I <sub>I</sub> = -18 mA		-1.5			V
V <sub>OH</sub>	High level output voltage	V <sub>ID</sub> = 200 mV, See Figure 7-6	I <sub>OH</sub> = -400 μA,	2.7			V
V <sub>OL</sub>	Low level output voltage	V <sub>ID</sub> = -200 mV, See Figure 7-6	I <sub>OL</sub> = 8 mA,			0.45	V
I <sub>OZ</sub>	High-impedance-state output current	V <sub>O</sub> = 0.4 V to 2.4 V		-20		20	μA
I <sub>I</sub>	Line input current	Other input = 0 V, See <sup>(3)</sup>	V <sub>I</sub> = 12 V			1	mA
			V <sub>I</sub> = -7 V	-0.8			
I <sub>IH</sub>	High-level enable-input current	V <sub>IH</sub> = 2.7 V		-100			μA
I <sub>IL</sub>	Low-level enable-input current	V <sub>IL</sub> = 0.4 V		-100			μA
r <sub>I</sub>	Input resistance			12			kΩ
I <sub>CC</sub>	Supply current	V <sub>I</sub> = 0 or V <sub>CC</sub> , No load	Receiver enabled and driver disabled			3.9	mA
			Receiver and driver disabled	SN55LBC176, SN65LBC176, SN65LBC176Q		0.25	
				SN75LBC176		0.2	

(1) All typical values are at V<sub>CC</sub> = 5 V, T<sub>A</sub> = 25°C.

(2) The algebraic convention, in which the less-positive (more-negative) limit is designated minimum, is used in this data sheet.

(3) This applies for both power on and power off. Refer to ANSI Standard RS-485 for exact conditions.

## 6.9 Receiver Switching Characteristics

over recommended ranges of supply voltage and operating free-air temperature, C<sub>L</sub> = 15 pF

PARAMETER	TEST CONDITIONS	SN55LBC176 SN65LBC176Q		SN65LBC176 SN75LBC176			UNIT	
		MIN	MAX	MIN	TYP <sup>(1)</sup>	MAX		
t <sub>PLH</sub>	Propagation delay time, low- to high-level single-ended output	V <sub>ID</sub> = -1.5 V to 1.5 V, See Figure 7-7	11	37	11		33	ns
t <sub>PHL</sub>	Propagation delay time, high- to low-level single-ended output		11	37	11		33	
t <sub>sk(p)</sub>	Pulse skew ( t <sub>PLH</sub> - t <sub>PHL</sub>  )			10		3	6	
t <sub>PZH</sub>	Output enable time to high level	See Figure 7-8		35			35	ns
t <sub>PZL</sub>	Output enable time to low level			35			30	
t <sub>PHZ</sub>	Output disable time from high level	See Figure 7-8		35			35	ns
t <sub>PLZ</sub>	Output disable time from low level			35			30	

(1) All typical values are at V<sub>CC</sub> = 5 V, T<sub>A</sub> = 25°C.

## 7 Parameter Measurement Information

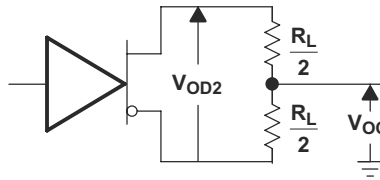

Figure 7-1. Driver  $V_{OD}$  and  $V_{OC}$

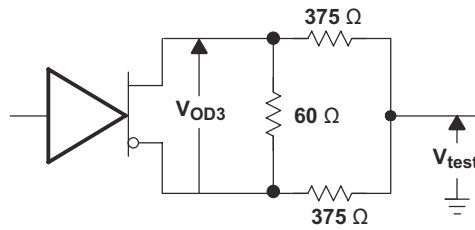

Figure 7-2. Driver  $V_{OD3}$

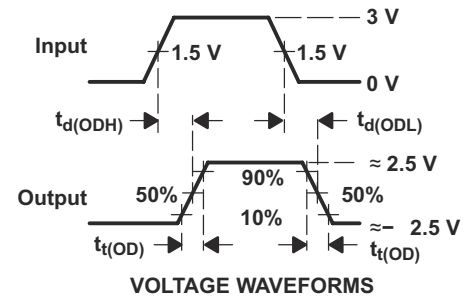
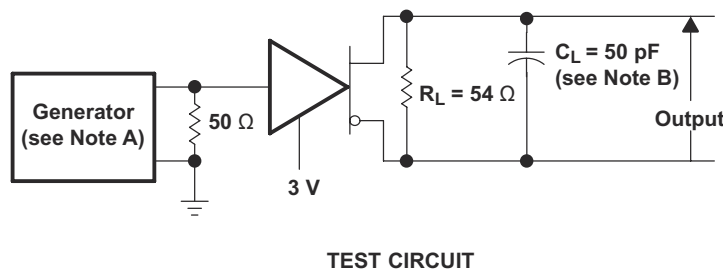

Figure 7-3. Driver Test Circuit and Voltage Waveforms

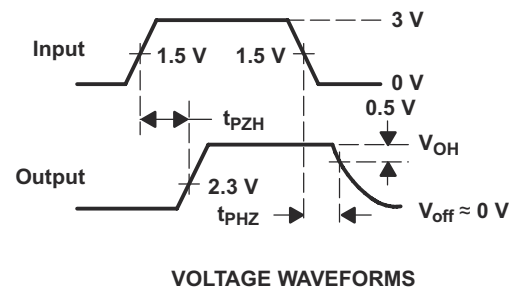
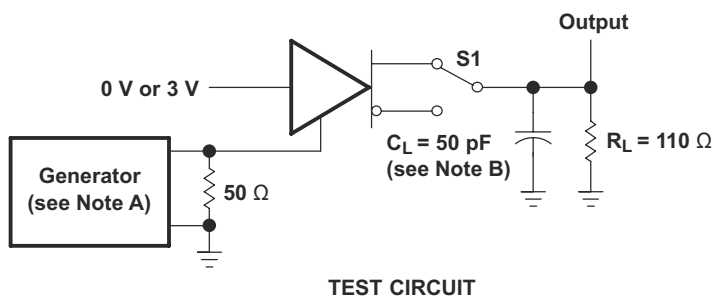

Figure 7-4. Driver Test Circuit and Voltage Waveforms

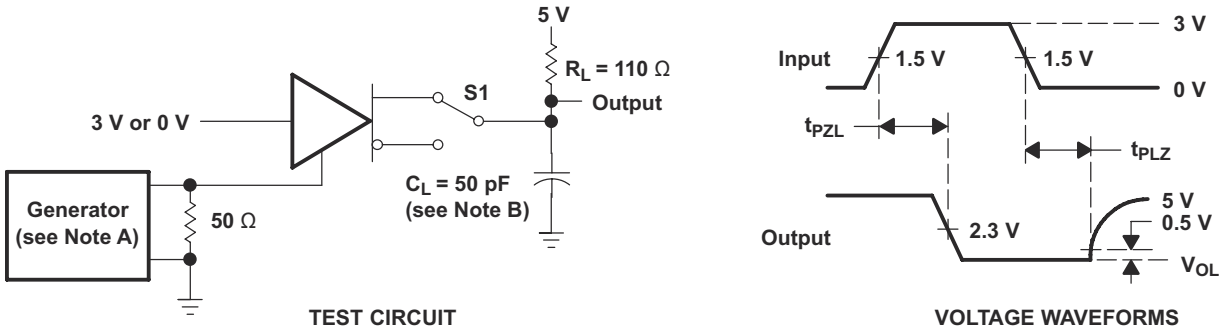

Figure 7-5. Driver Test Circuit and Voltage Waveforms

- A. The input pulse is supplied by a generator having the following characteristics: PRR  $\leq$  1 MHz, 50% duty cycle,  $t_r \leq$  6 ns,  $t_f \leq$  6 ns,  $Z_0 =$  50  $\Omega$ .
- B.  $C_L$  includes probe and jig capacitance.
- C. The input pulse is supplied by a generator having the following characteristics: PRR  $\leq$  1 MHz, 50% duty cycle,  $t_r \leq$  6 ns,  $t_f \leq$  6 ns,  $Z_0 =$  50  $\Omega$ .
- D.  $C_L$  includes probe and jig capacitance.

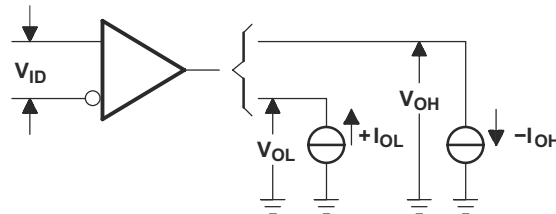

Figure 7-6. Receiver  $V_{OH}$  and  $V_{OL}$

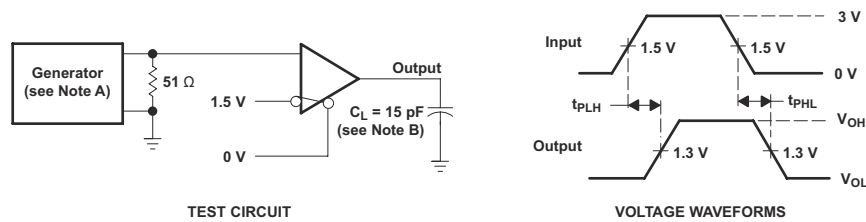
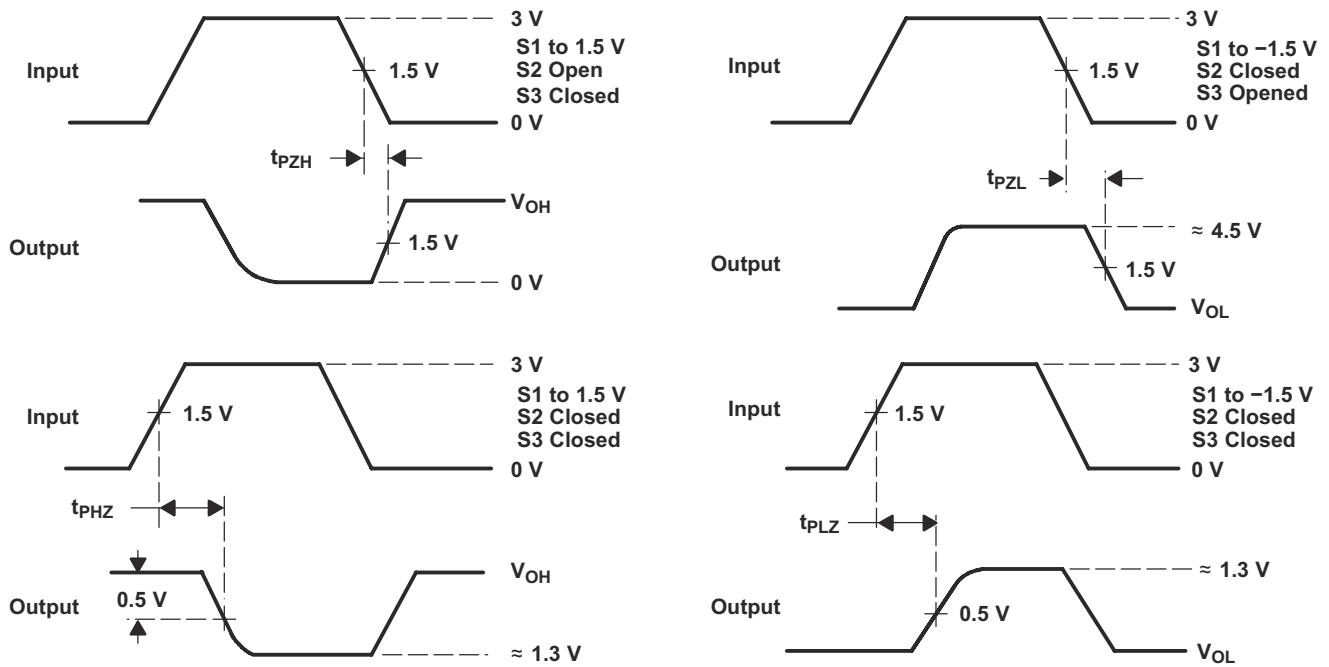
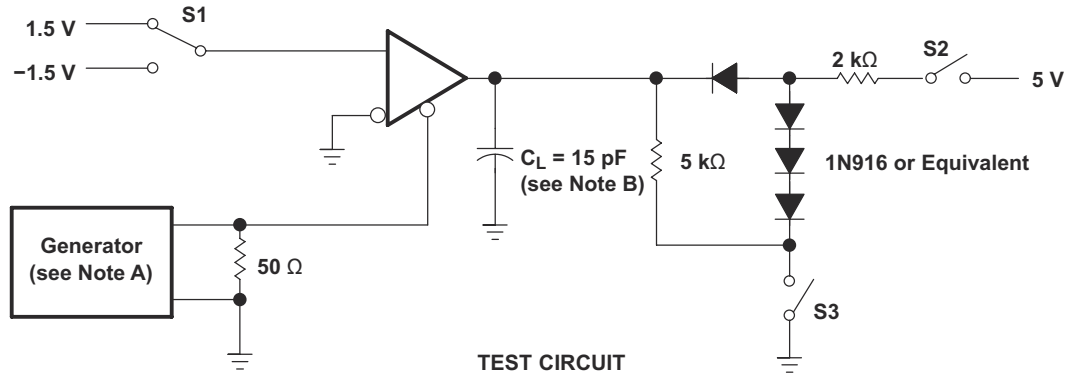

Figure 7-7. Receiver Test Circuit and Voltage Waveforms



**VOLTAGE WAVEFORMS**

- A. The input pulse is supplied by a generator having the following characteristics: PRR  $\leq$  1 MHz, 50% duty cycle,  $t_r \leq$  6 ns,  $t_f \leq$  6 ns,  $Z_O = 50 \Omega$ .
- B.  $C_L$  includes probe and jig capacitance.

**Figure 7-8. Receiver Test Circuit and Voltage Waveforms**

## 8 Detailed Description

### 8.1 Functional Block Diagram

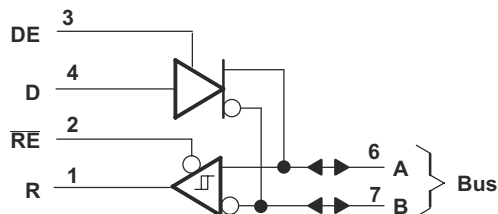
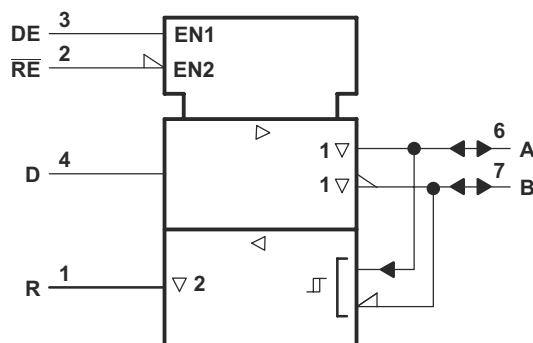

Figure 8-1. Logic Diagram (Positive Logic)



A. This symbol is in accordance with ANSI/IEEE Std 91-1984 and IEC Publication 617-12.

Figure 8-2. Logic Symbol(A)

### 8.2 Device Functional Modes

Table 8-1. Driver Function Tables<sup>(1)</sup>

DRIVER			
INPUT D	ENABLE DE	OUTPUTS	
		A	B
H	H	H	L
L	H	L	H
X	L	Z	Z

(1) H = high level, L = low level, ? = indeterminate, X = irrelevant, Z = high impedance (off)

Table 8-2. Receiver Function Tables<sup>(1)</sup>

RECEIVER		
DIFFERENTIAL INPUTS $V_{ID} = V_{IA} - V_{IB}$	ENABLE RE	OUTPUTS R
$V_{ID} \geq 0.2 \text{ V}$	L	H
$-0.2 \text{ V} < V_{ID} < 0.2 \text{ V}$	L	?
$V_{ID} \leq -0.2 \text{ V}$	L	L
X	H	Z
Open	L	H

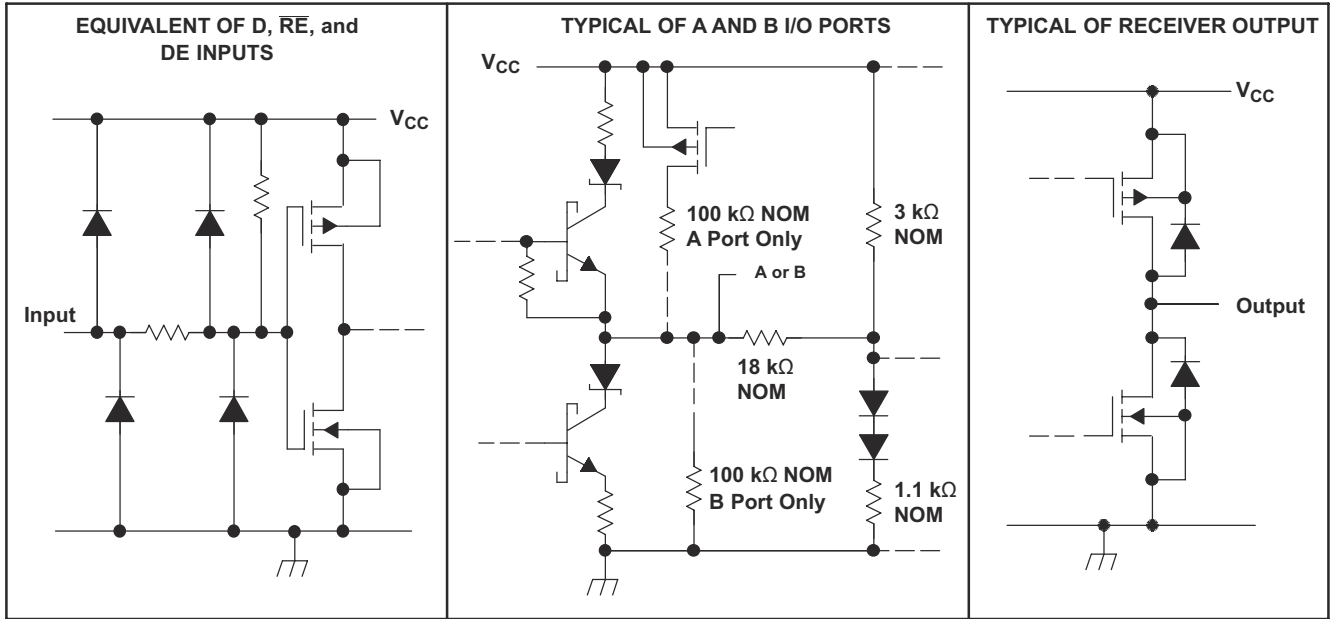

**Figure 8-3. Schematics of Inputs and Outputs**

## 9 Device and Documentation Support

### 9.1 Device Support

#### 9.1.1 Thermal Characteristics of IC Packages

$\theta_{JA}$  (Junction-to-Ambient Thermal Resistance) is defined as the difference in junction temperature to ambient temperature divided by the operating power.

$\theta_{JA}$  is NOT a constant and is a strong function of

- the PCB design (50% variation)
- altitude (20% variation)
- device power (5% variation)

$\theta_{JA}$  can be used to compare the thermal performance of packages if the specific test conditions are defined and used. Standardized testing includes specification of PCB construction, test chamber volume, sensor locations, and the thermal characteristics of holding fixtures.  $\theta_{JA}$  is often misused when it is used to calculate junction temperatures for other installations.

TI uses two test PCBs as defined by JEDEC specifications. The low-k board gives average in-use condition thermal performance and consists of a single trace layer 25 mm long and 2-oz thick copper. The high-k board gives best case in-use condition and consists of two 1-oz buried power planes with a single trace layer 25 mm long with 2-oz thick copper. A 4% to 50% difference in  $\theta_{JA}$  can be measured between these two test cards.

$\theta_{JC}$  (Junction-to-Case Thermal Resistance) is defined as difference in junction temperature to case divided by the operating power. It is measured by putting the mounted package up against a copper block cold plate to force heat to flow from die, through the mold compound into the copper block.

$\theta_{JC}$  is a useful thermal characteristic when a heatsink is applied to package. It is NOT a useful characteristic to predict junction temperature as it provides pessimistic numbers if the case temperature is measured in a non-standard system and junction temperatures are backed out. It can be used with  $\theta_{JB}$  in 1-dimensional thermal simulation of a package system.

$\theta_{JB}$  (Junction-to-Board Thermal Resistance) is defined to be the difference in the junction temperature and the PCB temperature at the center of the package (closest to the die) when the PCB is clamped in a cold-plate structure.  $\theta_{JB}$  is only defined for the high-k test card.

$\theta_{JB}$  provides an overall thermal resistance between the die and the PCB. It includes a bit of the PCB thermal resistance (especially for BGA's with thermal balls) and can be used for simple 1-dimensional network analysis of package system (see [Figure 9-1](#)).

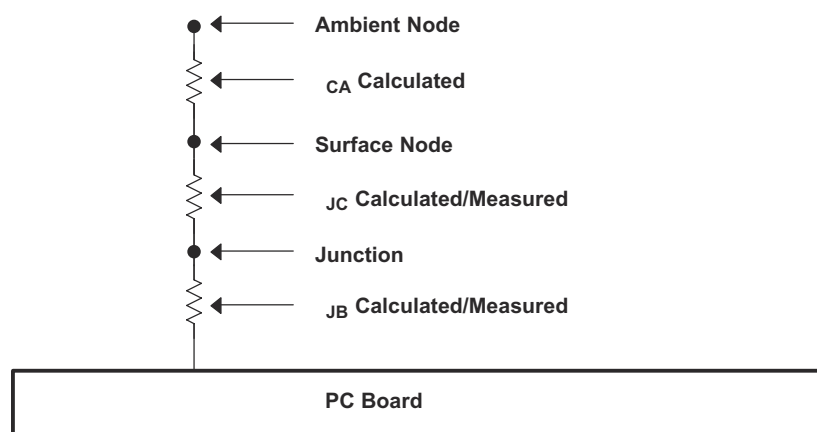

Figure 9-1. Thermal Resistance

### 9.2 Trademarks

LinBiCMOS™ is a trademark of Texas Instruments Incorporated.  
 All trademarks are the property of their respective owners.

### 9.3 Electrostatic Discharge Caution



This integrated circuit can be damaged by ESD. Texas Instruments recommends that all integrated circuits be handled with appropriate precautions. Failure to observe proper handling and installation procedures can cause damage.

ESD damage can range from subtle performance degradation to complete device failure. Precision integrated circuits may be more susceptible to damage because very small parametric changes could cause the device not to meet its published specifications.

### 9.4 Glossary

[TI Glossary](#) This glossary lists and explains terms, acronyms, and definitions.

## 10 Mechanical, Packaging, and Orderable Information

The following pages include mechanical, packaging, and orderable information. This information is the most current data available for the designated devices. This data is subject to change without notice and revision of this document. For browser-based versions of this data sheet, refer to the left-hand navigation.

**PACKAGING INFORMATION**

Orderable Device	Status (1)	Package Type	Package Drawing	Pins	Package Qty	Eco Plan (2)	Lead finish/ Ball material (6)	MSL Peak Temp (3)	Op Temp (°C)	Device Marking (4/5)	Samples
5962-9318301Q2A	ACTIVE	LCCC	FK	20	55	Non-RoHS & Green	SNPB	N / A for Pkg Type	-55 to 125	5962-9318301Q2A SNJ55 LBC176FK	<a href="#">Samples</a>
5962-9318301QPA	ACTIVE	CDIP	JG	8	50	Non-RoHS & Green	SNPB	N / A for Pkg Type	-55 to 125	9318301QPA SNJ55LBC176	<a href="#">Samples</a>
SN65LBC176DR	ACTIVE	SOIC	D	8	2500	RoHS & Green	NIPDAU	Level-1-260C-UNLIM	-40 to 85	6LB176	<a href="#">Samples</a>
SN65LBC176DRG4	ACTIVE	SOIC	D	8	2500	RoHS & Green	NIPDAU	Level-1-260C-UNLIM	-40 to 85	6LB176	<a href="#">Samples</a>
SN65LBC176P	ACTIVE	PDIP	P	8	50	RoHS & Green	NIPDAU	N / A for Pkg Type	-40 to 85	65LBC176	<a href="#">Samples</a>
SN65LBC176QDR	ACTIVE	SOIC	D	8	2500	RoHS & Green	NIPDAU	Level-1-260C-UNLIM	-40 to 125	LB176Q	<a href="#">Samples</a>
SN65LBC176QDRG4	ACTIVE	SOIC	D	8	2500	RoHS & Green	NIPDAU	Level-1-260C-UNLIM	-40 to 125	(J176Q1, LB176Q)	<a href="#">Samples</a>
SN75LBC176P	ACTIVE	PDIP	P	8	50	RoHS & Green	NIPDAU	N / A for Pkg Type	0 to 70	75LBC176	<a href="#">Samples</a>
SNJ55LBC176FK	ACTIVE	LCCC	FK	20	55	Non-RoHS & Green	SNPB	N / A for Pkg Type	-55 to 125	5962-9318301Q2A SNJ55 LBC176FK	<a href="#">Samples</a>
SNJ55LBC176JG	ACTIVE	CDIP	JG	8	50	Non-RoHS & Green	SNPB	N / A for Pkg Type	-55 to 125	9318301QPA SNJ55LBC176	<a href="#">Samples</a>

(1) The marketing status values are defined as follows:

**ACTIVE:** Product device recommended for new designs.

**LIFEBUY:** TI has announced that the device will be discontinued, and a lifetime-buy period is in effect.

**NRND:** Not recommended for new designs. Device is in production to support existing customers, but TI does not recommend using this part in a new design.

**PREVIEW:** Device has been announced but is not in production. Samples may or may not be available.

**OBSELETE:** TI has discontinued the production of the device.

(2) **RoHS:** TI defines "RoHS" to mean semiconductor products that are compliant with the current EU RoHS requirements for all 10 RoHS substances, including the requirement that RoHS substance do not exceed 0.1% by weight in homogeneous materials. Where designed to be soldered at high temperatures, "RoHS" products are suitable for use in specified lead-free processes. TI may reference these types of products as "Pb-Free".

**RoHS Exempt:** TI defines "RoHS Exempt" to mean products that contain lead but are compliant with EU RoHS pursuant to a specific EU RoHS exemption.

**Green:** TI defines "Green" to mean the content of Chlorine (Cl) and Bromine (Br) based flame retardants meet JS709B low halogen requirements of <=1000ppm threshold. Antimony trioxide based flame retardants must also meet the <=1000ppm threshold requirement.

(3) MSL, Peak Temp. - The Moisture Sensitivity Level rating according to the JEDEC industry standard classifications, and peak solder temperature.

(4) There may be additional marking, which relates to the logo, the lot trace code information, or the environmental category on the device.

(5) Multiple Device Markings will be inside parentheses. Only one Device Marking contained in parentheses and separated by a "~" will appear on a device. If a line is indented then it is a continuation of the previous line and the two combined represent the entire Device Marking for that device.

(6) Lead finish/Ball material - Orderable Devices may have multiple material finish options. Finish options are separated by a vertical ruled line. Lead finish/Ball material values may wrap to two lines if the finish value exceeds the maximum column width.

**Important Information and Disclaimer:**The information provided on this page represents TI's knowledge and belief as of the date that it is provided. TI bases its knowledge and belief on information provided by third parties, and makes no representation or warranty as to the accuracy of such information. Efforts are underway to better integrate information from third parties. TI has taken and continues to take reasonable steps to provide representative and accurate information but may not have conducted destructive testing or chemical analysis on incoming materials and chemicals. TI and TI suppliers consider certain information to be proprietary, and thus CAS numbers and other limited information may not be available for release.

In no event shall TI's liability arising out of such information exceed the total purchase price of the TI part(s) at issue in this document sold by TI to Customer on an annual basis.

**OTHER QUALIFIED VERSIONS OF SN55LBC176, SN65LBC176, SN75LBC176 :**

- Catalog : [SN75LBC176](#)
- Automotive : [SN65LBC176-Q1](#)
- Military : [SN55LBC176](#)

NOTE: Qualified Version Definitions:

- Catalog - TI's standard catalog product
- Automotive - Q100 devices qualified for high-reliability automotive applications targeting zero defects
- Military - QML certified for Military and Defense Applications

**TAPE AND REEL INFORMATION**

**QUADRANT ASSIGNMENTS FOR PIN 1 ORIENTATION IN TAPE**

\*All dimensions are nominal

Device	Package Type	Package Drawing	Pins	SPQ	Reel Diameter (mm)	Reel Width W1 (mm)	A0 (mm)	B0 (mm)	K0 (mm)	P1 (mm)	W (mm)	Pin1 Quadrant
SN65LBC176DR	SOIC	D	8	2500	330.0	12.4	6.4	5.2	2.1	8.0	12.0	Q1

**TAPE AND REEL BOX DIMENSIONS**

\*All dimensions are nominal

Device	Package Type	Package Drawing	Pins	SPQ	Length (mm)	Width (mm)	Height (mm)
SN65LBC176DR	SOIC	D	8	2500	356.0	356.0	35.0

**TUBE**

\*All dimensions are nominal

Device	Package Name	Package Type	Pins	SPQ	L (mm)	W (mm)	T (μm)	B (mm)
5962-9318301Q2A	FK	LCCC	20	55	506.98	12.06	2030	NA
SN65LBC176P	P	PDIP	8	50	506	13.97	11230	4.32
SN75LBC176P	P	PDIP	8	50	506	13.97	11230	4.32
SNJ55LBC176FK	FK	LCCC	20	55	506.98	12.06	2030	NA

## GENERIC PACKAGE VIEW

**FK 20**

**LCCC - 2.03 mm max height**

8.89 x 8.89, 1.27 mm pitch

LEADLESS CERAMIC CHIP CARRIER

This image is a representation of the package family, actual package may vary.  
Refer to the product data sheet for package details.



4229370VA\



D0008A

# PACKAGE OUTLINE

SOIC - 1.75 mm max height

SMALL OUTLINE INTEGRATED CIRCUIT



4214825/C 02/2019

NOTES:

- Linear dimensions are in inches [millimeters]. Dimensions in parenthesis are for reference only. Controlling dimensions are in inches. Dimensioning and tolerancing per ASME Y14.5M.
- This drawing is subject to change without notice.
- This dimension does not include mold flash, protrusions, or gate burrs. Mold flash, protrusions, or gate burrs shall not exceed  $.006$  [0.15] per side.
- This dimension does not include interlead flash.
- Reference JEDEC registration MS-012, variation AA.

# EXAMPLE BOARD LAYOUT

D0008A

SOIC - 1.75 mm max height

SMALL OUTLINE INTEGRATED CIRCUIT



LAND PATTERN EXAMPLE  
EXPOSED METAL SHOWN  
SCALE:8X



SOLDER MASK DETAILS

4214825/C 02/2019

NOTES: (continued)

6. Publication IPC-7351 may have alternate designs.

7. Solder mask tolerances between and around signal pads can vary based on board fabrication site.

# EXAMPLE STENCIL DESIGN

D0008A

SOIC - 1.75 mm max height

SMALL OUTLINE INTEGRATED CIRCUIT



SOLDER PASTE EXAMPLE  
BASED ON .005 INCH [0.125 MM] THICK STENCIL  
SCALE:8X

4214825/C 02/2019

NOTES: (continued)

8. Laser cutting apertures with trapezoidal walls and rounded corners may offer better paste release. IPC-7525 may have alternate design recommendations.
9. Board assembly site may have different recommendations for stencil design.

P (R-PDIP-T8)

PLASTIC DUAL-IN-LINE PACKAGE



- NOTES:
- A. All linear dimensions are in inches (millimeters).
  - B. This drawing is subject to change without notice.
  - C. Falls within JEDEC MS-001 variation BA.

# PACKAGE OUTLINE

## JG0008A

### CDIP - 5.08 mm max height

CERAMIC DUAL IN-LINE PACKAGE

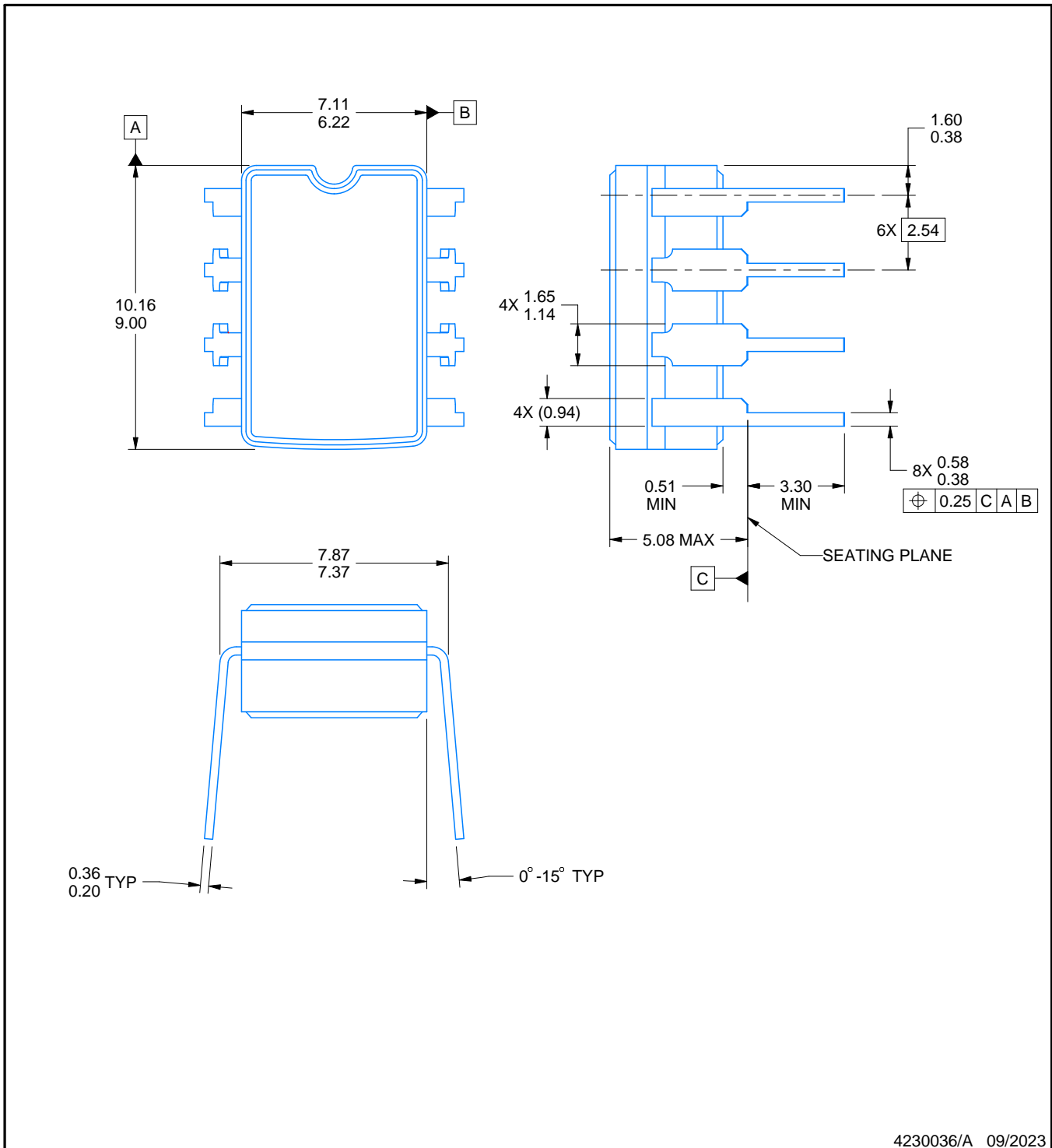

4230036/A 09/2023

#### NOTES:

1. All linear dimensions are in millimeters. Any dimensions in parenthesis are for reference only. Dimensioning and tolerancing per ASME Y14.5M.
2. This drawing is subject to change without notice.
3. This package can be hermetically sealed with a ceramic lid using glass frit.
4. Index point is provided on cap for terminal identification.
5. Falls within MIL STD 1835 GDIP1-T8

# EXAMPLE BOARD LAYOUT

JG0008A

CDIP - 5.08 mm max height

CERAMIC DUAL IN-LINE PACKAGE

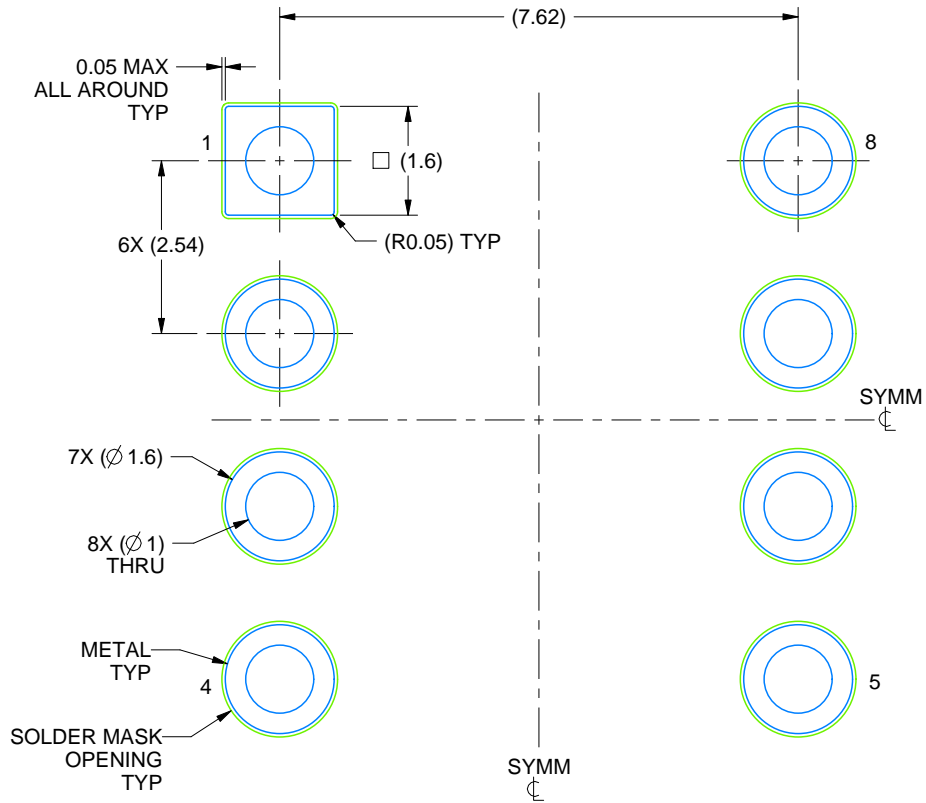

LAND PATTERN EXAMPLE  
NON SOLDER MASK DEFINED  
SCALE: 9X

4230036/A 09/2023