

TLC7528C, TLC7528E, TLC7528I DUAL 8-BIT MULTIPLYING DIGITAL-TO-ANALOG CONVERTERS

SLAS062E – JANUARY 1987 – REVISED NOVEMBER 2008

- Easily Interfaced to Microprocessors
- On-Chip Data Latches
- Monotonic Over the Entire A/D Conversion Range
- Interchangeable With Analog Devices AD7528 and PMI PM-7528
- Fast Control Signaling for Digital Signal Processor (DSP) Applications Including Interface With TMS320
- Voltage-Mode Operation
- CMOS Technology

KEY PERFORMANCE SPECIFICATIONS	
Resolution	8 bits
Linearity Error	1/2LSB
Power Dissipation at $V_{DD} = 5V$	20mW
Settling Time at $V_{DD} = 5V$	100ns
Propagation Delay Time at $V_{DD} = 5V$	80ns

description

The TLC7528C, TLC7528E, and TLC7528I are dual, 8-bit, digital-to-analog converters (DACs) designed with separate on-chip data latches and feature exceptionally close DAC-to-DAC matching. Data are transferred to either of the two DAC data latches through a common, 8-bit, input port. Control input $\overline{DACA/DACB}$ determines which DAC is to be loaded. The load cycle of these devices is similar to the write cycle of a random-access memory, allowing easy interface to most popular microprocessor buses and output ports. Segmenting the high-order bits minimizes glitches during changes in the most significant bits, where glitch impulse is typically the strongest.

These devices operate from a 5V to 15V power supply and dissipates less than 15mW (typical). The 2- or 4-quadrant multiplying makes these devices a sound choice for many microprocessor-controlled gain-setting and signal-control applications. It can be operated in voltage mode, which produces a voltage output rather than a current output. Refer to the typical application information in this data sheet.

The TLC7528C is characterized for operation from 0°C to +70°C. The TLC7528I is characterized for operation from –25°C to +85°C. The TLC7528E is characterized for operation from –40°C to +85°C.

DW, N OR PW PACKAGE
(TOP VIEW)

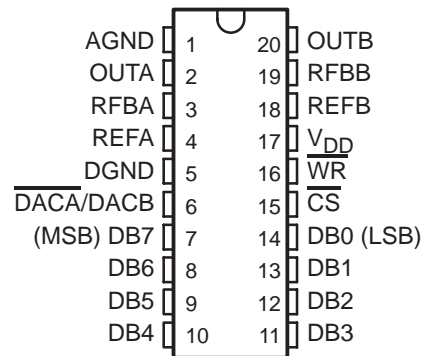

FN PACKAGE
(TOP VIEW)

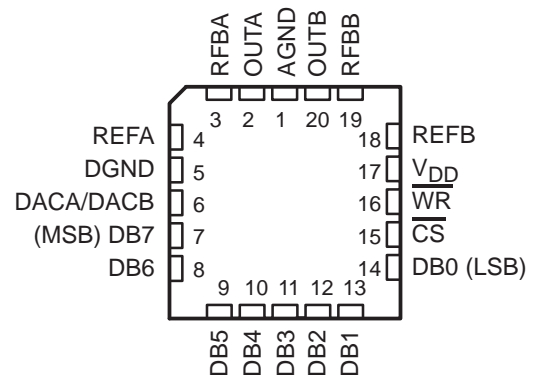

Please be aware that an important notice concerning availability, standard warranty, and use in critical applications of Texas Instruments semiconductor products and disclaimers thereto appears at the end of this data sheet.

All trademarks are the property of their respective owners.

PRODUCTION DATA information is current as of publication date. Products conform to specifications per the terms of Texas Instruments standard warranty. Production processing does not necessarily include testing of all parameters.



POST OFFICE BOX 655303 • DALLAS, TEXAS 75265

Copyright © 2000–2008, Texas Instruments Incorporated

TLC7528C, TLC7528E, TLC7528I

DUAL 8-BIT MULTIPLYING

DIGITAL-TO-ANALOG CONVERTERS

SLAS062E – JANUARY 1987 – REVISED NOVEMBER 2008

functional block diagram

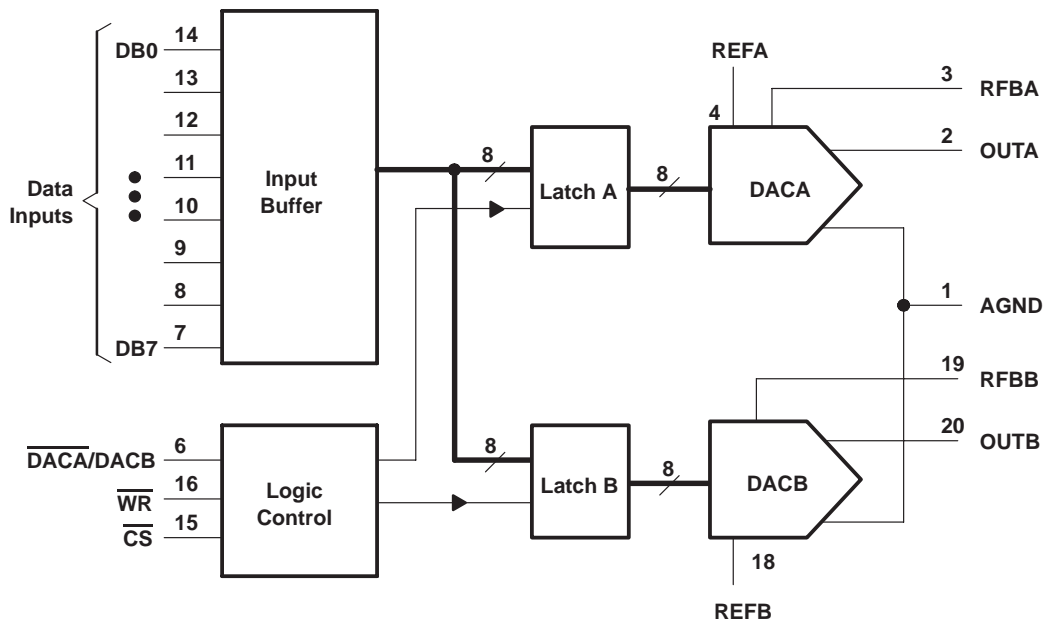

operating sequence

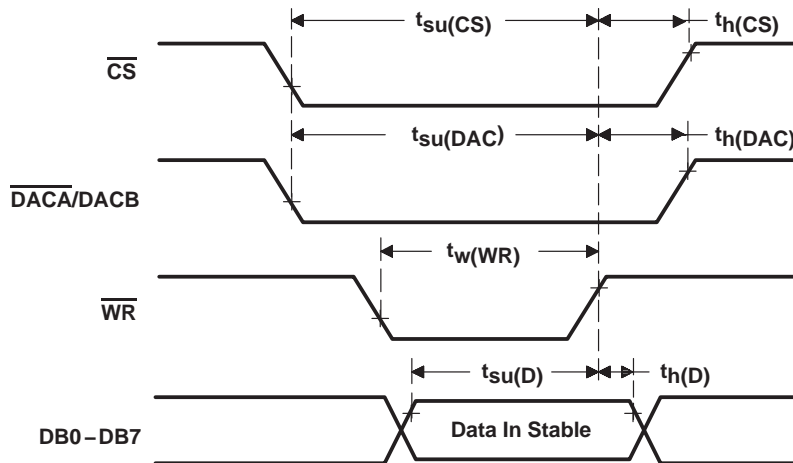

absolute maximum ratings over operating free-air temperature range (unless otherwise noted)†

Supply voltage range, V_{DD} (to AGND or DGND)	–0.3V to 16.5V
Voltage between AGND and DGND	$\pm V_{DD}$
Input voltage range, V_I (to DGND)	–0.3V to $V_{DD} + 0.3$
Reference voltage, V_{refA} or V_{refB} (to AGND)	$\pm 25V$
Feedback voltage V_{RFBA} or V_{RFBB} (to AGND)	$\pm 25V$
Input voltage (voltage mode out A, out B to AGND)	–0.3V to $V_{DD} + 0.3$
Output voltage, V_{OA} or V_{OB} (to AGND)	$\pm 25V$
Peak input current	10 μ A
Operating free-air temperature range, T_A :	
TLC7528C	0°C to +70°C
TLC7528I	–25°C to +85°C
TLC7528E	–40°C to +85°C
Storage temperature range, T_{stg}	–65°C to +150°C
Case temperature for 10 seconds, T_C : FN package	+260°C
Lead temperature 1,6mm (1/16 inch) from case for 10 seconds: DW or N package	+260°C

† Stresses beyond those listed under “absolute maximum ratings” may cause permanent damage to the device. These are stress ratings only, and functional operation of the device at these or any other conditions beyond those indicated under “recommended operating conditions” is not implied. Exposure to absolute-maximum-rated conditions for extended periods may affect device reliability.

package/ordering information

For the most current package and ordering information, see the Package Option Addendum at the end of this document, or see the TI website at www.ti.com.

recommended operating conditions

	$V_{DD} = 4.75V \text{ to } 5.25V$			$V_{DD} = 14.5V \text{ to } 15.5V$			UNIT
	MIN	NOM	MAX	MIN	NOM	MAX	
Reference voltage, V_{refA} or V_{refB}	±10			±10			V
High-level input voltage, V_{IH}	2.4			13.5			V
Low-level input voltage, V_{IL}	0.8			1.5			V
\overline{CS} setup time, $t_{su}(CS)$	50			50			ns
\overline{CS} hold time, $t_h(CS)$	0			0			ns
DAC select setup time, $t_{su}(DAC)$	50			50			ns
DAC select hold time, $t_h(DAC)$	10			10			ns
Data bus input setup time $t_{su}(D)$	25			25			ns
Data bus input hold time $t_h(D)$	10			10			ns
Pulse duration, \overline{WR} low, $t_w(WR)$	50			50			ns
Operating free-air temperature, T_A	TLC7628C	0		+70		°C	
	TLC7628I	–25		+85			
	TLC7628E	–40		+85			

TLC7528C, TLC7528E, TLC7528I
DUAL 8-BIT MULTIPLYING
DIGITAL-TO-ANALOG CONVERTERS

SLAS062E – JANUARY 1987 – REVISED NOVEMBER 2008

electrical characteristics over recommended operating free-air temperature range,
 $V_{refA} = V_{refB} = 10V$, V_{OA} and V_{OB} at 0V (unless otherwise noted)

PARAMETER		TEST CONDITIONS	$V_{DD} = 5V$			$V_{DD} = 15V$			UNIT
			MIN	TYP†	MAX	MIN	TYP†	MAX	
I_{IH}	High-level input current	$V_I = V_{DD}$			10			10	μA
I_{IL}	Low-level input current	$V_I = 0$	5	12	-10	5	12	-10	μA
Reference input impedance REFA or REFB to AGND					20			20	$k\Omega$
I_{Ikg}	Output leakage current	OUTA DAC data latch loaded with 00000000, $V_{refA} = \pm 10V$			± 400			± 200	nA
		OUTB DAC data latch loaded with 00000000, $V_{refB} = \pm 10V$			± 400			± 200	
Input resistance match (REFA to REFB)					$\pm 1\%$			$\pm 1\%$	
DC supply sensitivity, $\Delta gain/\Delta V_{DD}$		$\Delta V_{DD} = \pm 10\%$			0.04			0.02	%/%
I_{DD}	Supply current (quiescent)	All digital inputs at V_{IHmin} or V_{ILmax}			2			2	mA
I_{DD}	Supply current (standby)	All digital inputs at 0V or V_{DD}			0.5			0.5	mA
C_i	Input capacitance	DB0–DB7			10			10	pF
		\overline{WR} , \overline{CS} , DACA/DACB			15			15	pF
C_o	Output capacitance (OUTA, OUTB)	DAC data latches loaded with 00000000			50			50	pF
		DAC data latches loaded with 11111111			120			120	

† All typical values are at $T_A = +25^\circ C$.



operating characteristics over recommended operating free-air temperature range,
 $V_{refA} = V_{refB} = 10V$, V_{OA} and V_{OB} at 0V (unless otherwise noted)

PARAMETER		TEST CONDITIONS	$V_{DD} = 5V$			$V_{DD} = 15V$			UNIT
			MIN	TYP	MAX	MIN	TYP	MAX	
Linearity error					±1/2			±1/2	LSB
Settling time (to 1/2LSB)		See Note 1			100			100	ns
Gain error		See Note 2			2.5			2.5	LSB
AC feedthrough	REFA to OUTA	See Note 3			-65			-65	dB
	REFB to OUTB				-65			-65	
Temperature coefficient of gain		See Note 4			0.007			0.0035	%FSR/°C
Propagation delay (from digital input to 90% of final analog output current)		See Note 5			80			80	ns
Channel-to-channel isolation	REFA to OUTB	See Note 6			77			77	dB
	REFB to OUTA	See Note 7			77			77	
Digital-to-analog glitch impulse area		Measured for code transition from 00000000 to 11111111, $T_A = +25^\circ C$			160			440	nV-s
Digital crosstalk		Measured for code transition from 00000000 to 11111111, $T_A = +25^\circ C$			30			60	nV-s
Harmonic distortion		$V_i = 6V$, $f = 1kHz$, $T_A = +25^\circ C$			-85			-85	dB

- NOTES:
1. OUTA, OUTB load = 100Ω, $C_{ext} = 13pF$; \overline{WR} and \overline{CS} at 0V; DB0-DB7 at 0V to V_{DD} or V_{DD} to 0V.
 2. Gain error is measured using an internal feedback resistor. Nominal full scale range (FSR) = $V_{ref} - 1LSB$.
 3. $V_{ref} = 20V$ peak-to-peak, 100kHz sine wave; DAC data latches loaded with 00000000.
 4. Temperature coefficient of gain measured from 0°C to +25°C or from +25°C to +70°C.
 5. $V_{refA} = V_{refB} = 10V$; OUTA/OUTB load = 100Ω, $C_{ext} = 13pF$; \overline{WR} and \overline{CS} at 0V; DB0-DB7 at 0V to V_{DD} or V_{DD} to 0V.
 6. Both DAC latches loaded with 11111111; $V_{refA} = 20V$ peak-to-peak, 100kHz sine wave; $V_{refB} = 0$; $T_A = +25^\circ C$.
 7. Both DAC latches loaded with 11111111; $V_{refB} = 20V$ peak-to-peak, 100kHz sine wave; $V_{refA} = 0$; $T_A = +25^\circ C$.

PRINCIPLES OF OPERATION

These devices contain two identical, 8-bit-multiplying DACs, DACA and DACB. Each DAC consists of an inverted R-2R ladder, analog switches, and input data latches. Binary-weighted currents are switched between DAC output and AGND, thus maintaining a constant current in each ladder leg independent of the switch state. Most applications require only the addition of an external operational amplifier and voltage reference. A simplified DAC circuit for DACA with all digital inputs low is shown in Figure 1.

Figure 2 shows the DACA equivalent circuit. A similar equivalent circuit can be drawn for DACB. Both DACs share the analog ground terminal 1 (AGND). With all digital inputs high, the entire reference current flows to OUTA. A small leakage current (I_{lkg}) flows across internal junctions, and as with most semiconductor devices, doubles every 10°C. C_o is due to the parallel combination of the NMOS switches and has a value that depends on the number of switches connected to the output. The range of C_o is 50pF to 120pF maximum. The equivalent output resistance (r_o) varies with the input code from 0.8R to 3R where R is the nominal value of the ladder resistor in the R-2R network.

These devices interface to a microprocessor through the data bus, \overline{CS} , \overline{WR} , and $\overline{DACA/DACB}$ control signals. When \overline{CS} and \overline{WR} are both low, the TLC7528 analog output, specified by the $\overline{DACA/DACB}$ control line, responds to the activity on the DB0-DB7 data bus inputs. In this mode, the input latches are transparent and input data directly affects the analog output. When either the \overline{CS} signal or \overline{WR} signal goes high, the data on the DB0-DB7 inputs are latched until the \overline{CS} and \overline{WR} signals go low again. When \overline{CS} is high, the data inputs are disabled regardless of the state of the \overline{WR} signal.

TLC7528C, TLC7528E, TLC7528I DUAL 8-BIT MULTIPLYING DIGITAL-TO-ANALOG CONVERTERS

SLAS062E – JANUARY 1987 – REVISED NOVEMBER 2008

PRINCIPLES OF OPERATION

The digital inputs of these devices provide TTL compatibility when operated from a supply voltage of 5V. These devices can operate with any supply voltage in the range from 5V to 15V; however, input logic levels are not TTL-compatible above 5V.

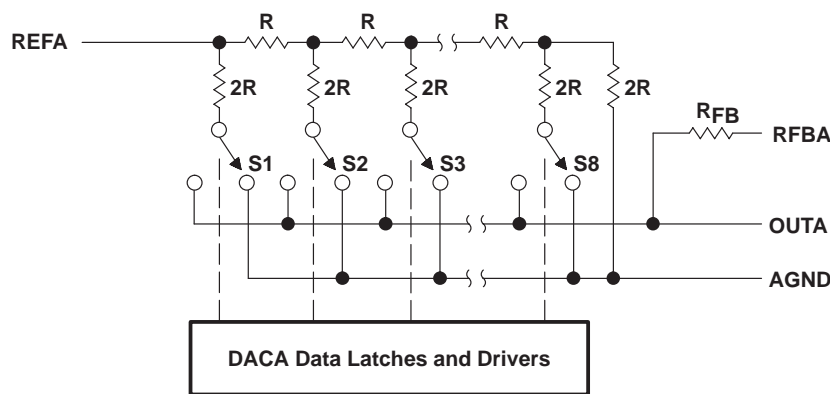

Figure 1. Simplified Functional Circuit for DACA

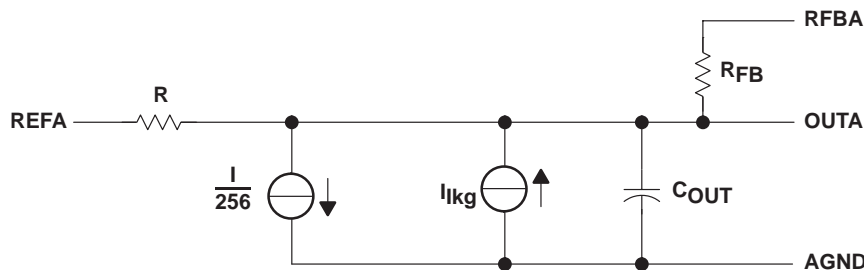

Figure 2. TLC7528 Equivalent Circuit, DACA Latch Loaded With 11111111

MODE SELECTION TABLE

DACA/DACB	\overline{CS}	\overline{WR}	DACA	DACB
L	L	L	Write	Hold
H	L	L	Hold	Write
X	H	X	Hold	Hold
X	X	H	Hold	Hold

L = low level, H = high level, X = don't care

APPLICATION INFORMATION

These devices are capable of performing 2-quadrant or full 4-quadrant multiplication. Circuit configurations for 2-quadrant and 4-quadrant multiplication are shown in Figure 3 and Figure 4. Table 1 and Table 2 summarize input coding for unipolar and bipolar operation, respectively.

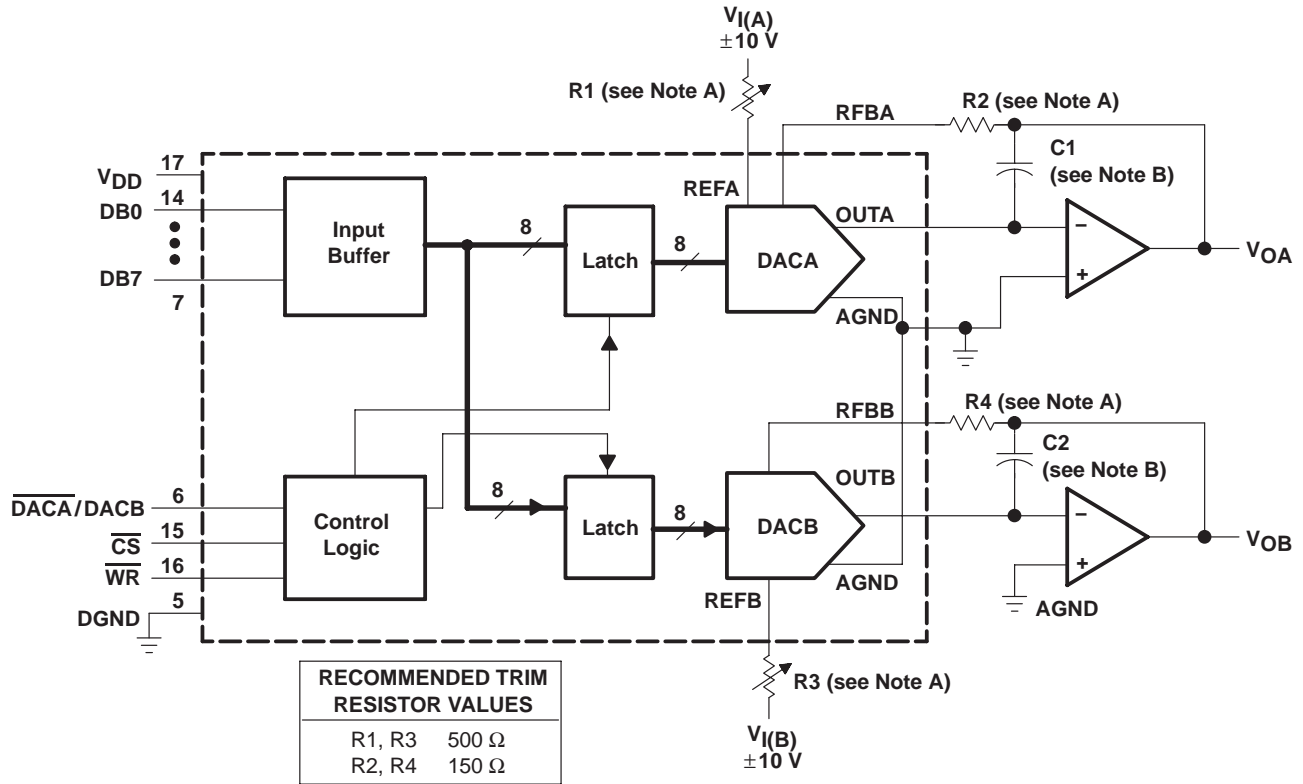

- NOTES: A. R1, R2, R3, and R4 are used only if gain adjustment is required. See table for recommended values. Make gain adjustment with digital input of 255.
- B. C1 and C2 phase compensation capacitors (10pF to 15pF) are required when using high-speed amplifiers to prevent ringing or oscillation.

Figure 3. Unipolar Operation (2-Quadrant Multiplication)

TLC7528C, TLC7528E, TLC7528I

DUAL 8-BIT MULTIPLYING DIGITAL-TO-ANALOG CONVERTERS

SLAS062E – JANUARY 1987 – REVISED NOVEMBER 2008

APPLICATION INFORMATION

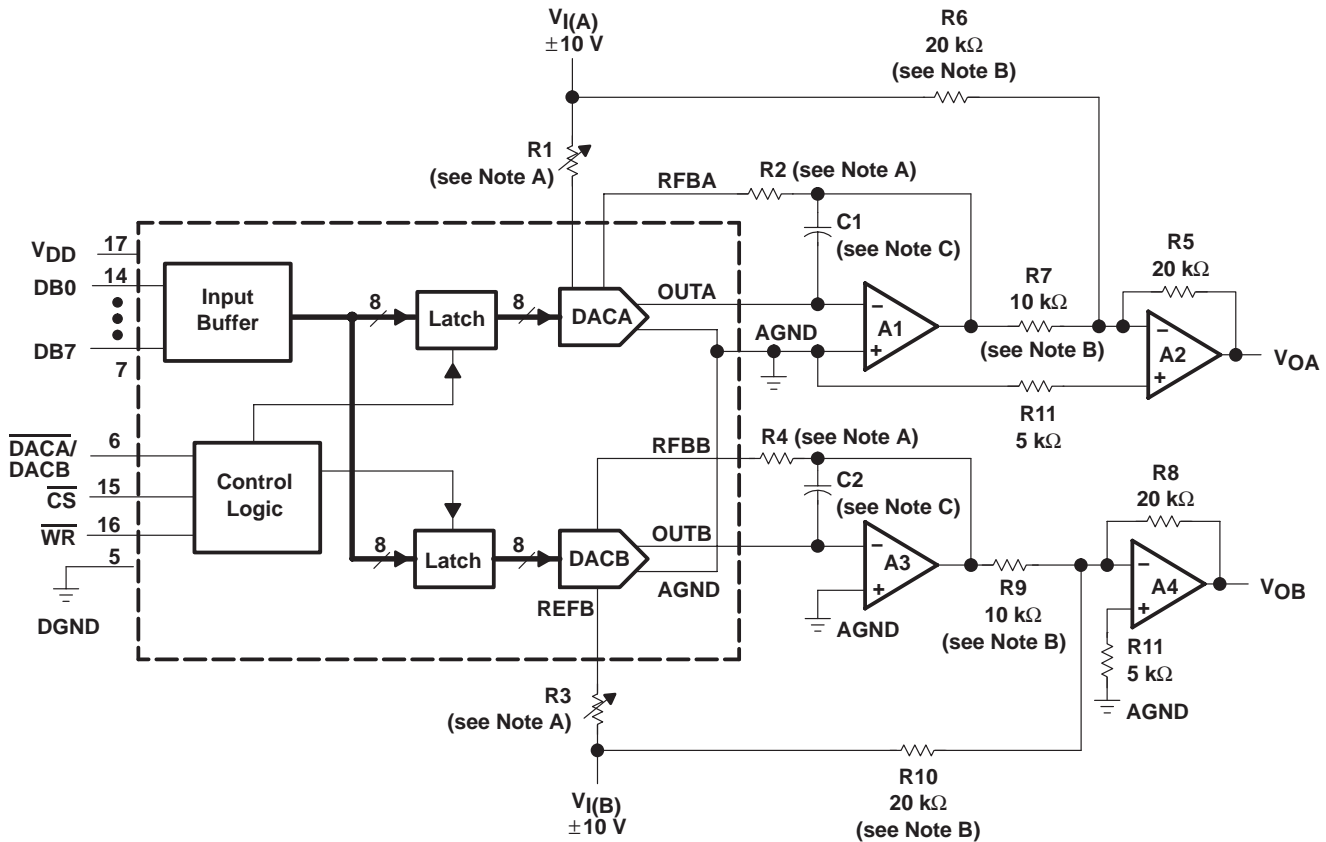

- NOTES: A. R1, R2, R3, and R4 are used only if gain adjustment is required. See table in Figure 3 for recommended values. Adjust R1 for $V_{OA} = 0V$ with code 10000000 in DACA latch. Adjust R3 for $V_{OB} = 0V$ with 10000000 in DACB latch.
- B. Matching and tracking are essential for resistor pairs R6, R7, R9, and R10.
- C. C1 and C2 phase compensation capacitors (10pF to 15pF) may be required if A1 and A3 are high-speed amplifiers.

Figure 4. Bipolar Operation (4-Quadrant Operation)

Table 1. Unipolar Binary Code

DAC LATCH CONTENTS		ANALOG OUTPUT
MSB	LSB†	
1	11111111	$-V_I (255/256)$
1	00000001	$-V_I (129/256)$
1	00000000	$-V_I (128/256) = -V_I/2$
0	11111111	$-V_I (127/256)$
0	00000001	$-V_I (1/256)$
0	00000000	$-V_I (0/256) = 0$

† 1LSB = $(2^{-8})V_I$

Table 2. Bipolar (Offset Binary) Code

DAC LATCH CONTENTS		ANALOG OUTPUT
MSB	LSB‡	
1	11111111	$V_I (127/128)$
1	00000001	$V_I (1/128)$
1	00000000	0V
0	11111111	$-V_I (1/128)$
0	00000001	$-V_I (127/128)$
0	00000000	$-V_I (128/128)$

‡ 1LSB = $(2^{-7})V_I$

APPLICATION INFORMATION

microprocessor interface information

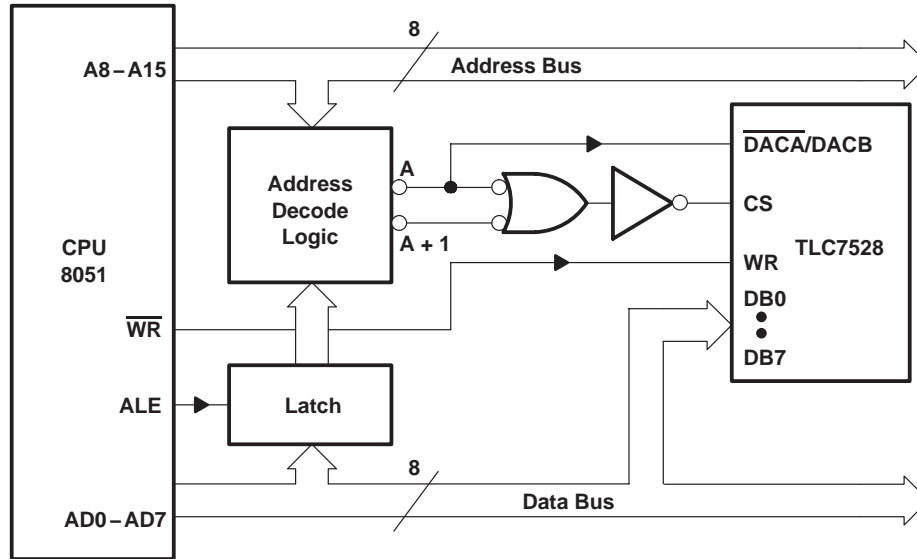

NOTE A: A = decoded address for TLC7528 DACA
 A + 1 = decoded address for TLC7528 DACB

Figure 5. TLC7528: Intel 8051 Interface

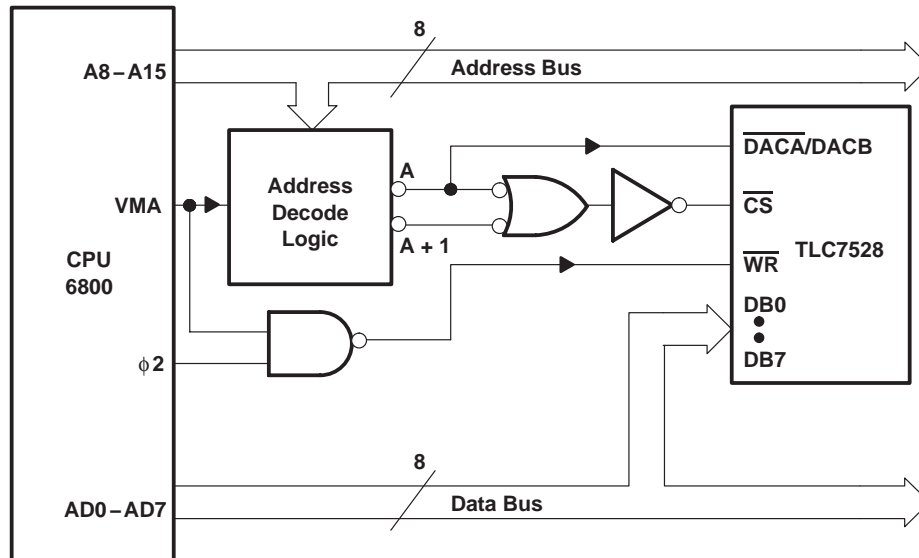

NOTE A: A = decoded address for TLC7528 DACA
 A + 1 = decoded address for TLC7528 DACB

Figure 6. TLC7528: 6800 Interface

TLC7528C, TLC7528E, TLC7528I
DUAL 8-BIT MULTIPLYING
DIGITAL-TO-ANALOG CONVERTERS

SLAS062E – JANUARY 1987 – REVISED NOVEMBER 2008

APPLICATION INFORMATION

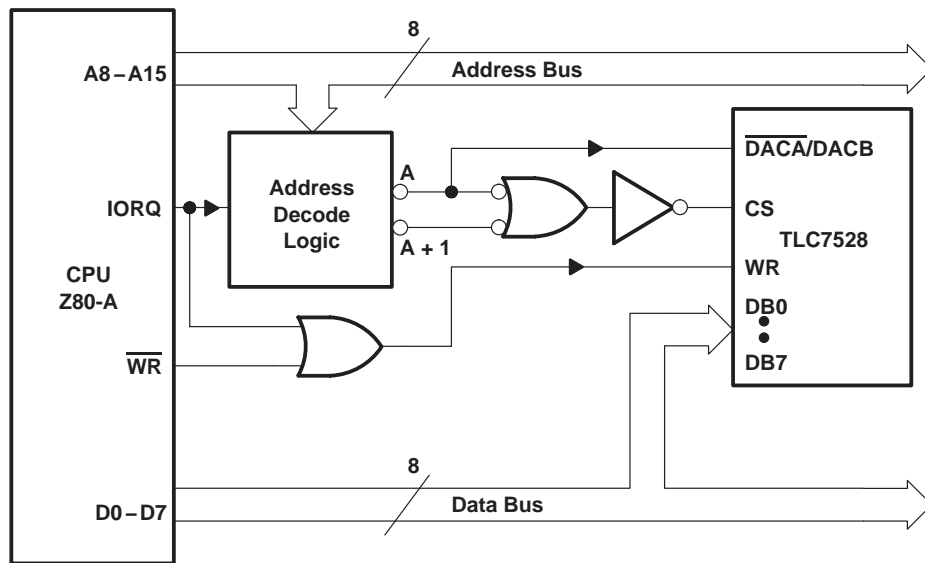

NOTE A: A = decoded address for TLC7528 DACA
 A + 1 = decoded address for TLC7528 DACB

Figure 7. TLC7528 To Z-80A Interface

programmable window detector

The programmable window comparator shown in Figure 8 determines if the voltage applied to the DAC feedback resistors is within the limits programmed into the data latches of these devices. Input signal range depends on the reference and polarity; that is, the test input range is 0 to $-V_{ref}$. The DACA and DACB data latches are programmed with the upper and lower test limits. A signal within the programmed limits drives the output high.

APPLICATION INFORMATION

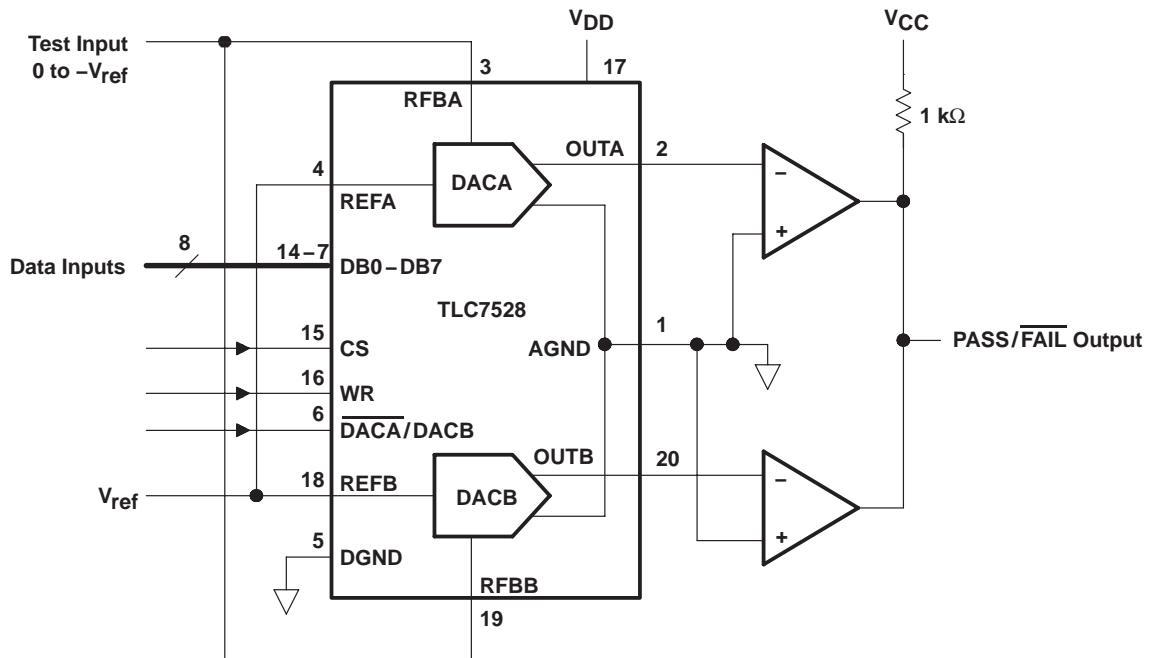

Figure 8. Digitally-Programmable Window Comparator (Upper- and Lower-Limit Tester)

digitally-controlled signal attenuator

Figure 9 shows a TLC7528 configured as a two-channel programmable attenuator. Applications include stereo audio and telephone signal level control. Table 3 shows input codes vs attenuation for a 0dB to 15.5dB range.

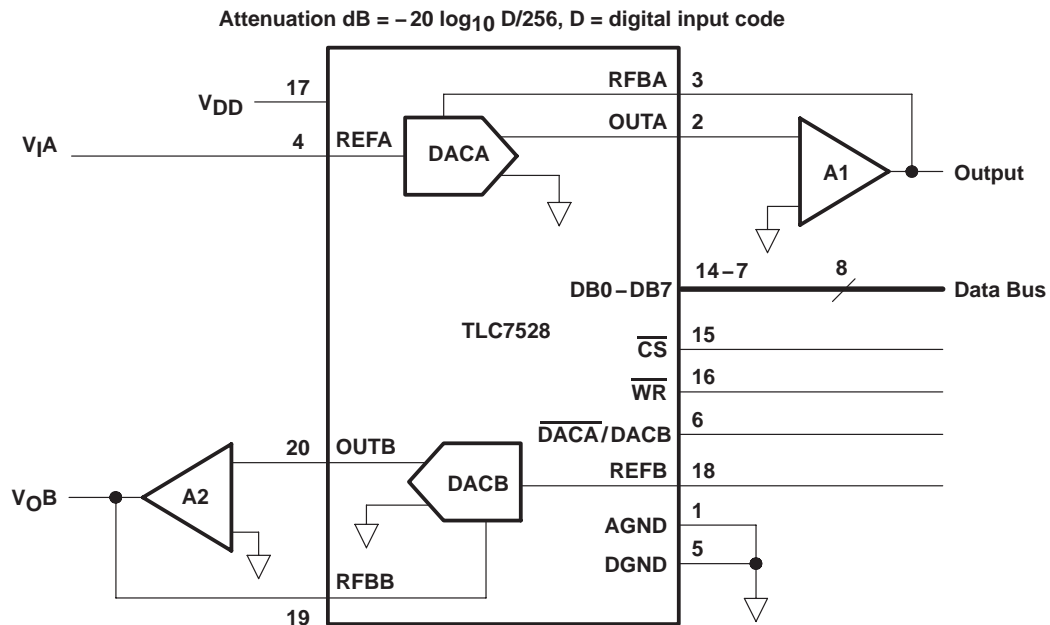

Figure 9. Digitally Controlled Dual Telephone Attenuator

TLC7528C, TLC7528E, TLC7528I
DUAL 8-BIT MULTIPLYING
DIGITAL-TO-ANALOG CONVERTERS

SLAS062E – JANUARY 1987 – REVISED NOVEMBER 2008

APPLICATION INFORMATION

Table 3. Attenuation vs DACA, DACB Code

ATTEN (dB)	DAC INPUT CODE	CODE IN DECIMAL	ATTN (dB)	DAC INPUT CODE	CODE IN DECIMAL
0	1 1 1 1 1 1 1 1	255	8.0	0 1 1 0 0 1 1 0	102
0.5	1 1 1 1 0 0 1 0	242	8.5	0 1 1 0 0 0 0 0	96
1.0	1 1 1 0 0 1 0 0	228	9.0	0 1 0 1 1 0 1 1	91
1.5	1 1 0 1 0 1 1 1	215	9.5	0 1 0 1 0 1 1 0	86
2.0	1 1 0 0 1 0 1 1	203	10.0	0 1 0 1 0 0 0 1	81
2.5	1 1 0 0 0 0 0 0	192	10.5	0 1 0 0 1 1 0 0	76
3.0	1 0 1 1 0 1 0 1	181	11.0	0 1 0 0 1 0 0 0	72
3.5	1 0 1 0 1 0 1 1	171	11.5	0 1 0 0 0 1 0 0	68
4.0	1 0 1 0 0 0 1 0	162	12.0	0 1 0 0 0 0 0 0	64
4.5	1 0 0 1 1 0 0 0	152	12.5	0 0 1 1 1 1 0 1	61
5.0	1 0 0 1 1 1 1 1	144	13.0	0 0 1 1 1 0 0 1	57
5.5	1 0 0 0 1 0 0 0	136	13.5	0 0 1 1 0 1 1 0	54
6.0	1 0 0 0 0 0 0 0	128	14.0	0 0 1 1 0 0 1 1	51
6.5	0 1 1 1 1 0 0 1	121	14.5	0 0 1 1 0 0 0 0	48
7.0	0 1 1 1 0 0 1 0	114	15.0	0 0 1 0 1 1 1 0	46
7.5	0 1 1 0 1 1 0 0	108	15.5	0 0 1 0 1 0 1 1	43

programmable state-variable filter

This programmable state-variable or universal filter configuration provides low-pass, high-pass, and bandpass outputs, and is suitable for applications requiring microprocessor control of filter parameters.

As shown in Figure 10, DACA1 and DACB1 control the gain and Q of the filter while DACA2 and DACB2 control the cutoff frequency. Both halves of the DACA2 and DACB2 must track accurately in order for the cutoff-frequency equation to be true. With the TLC7528, this validity is easy to achieve.

$$f_c = \frac{1}{2\pi R1C1}$$

The programmable range for the cutoff or center frequency is 0kHz to 15kHz with a Q ranging from 0.3 to 4.5. This parameter defines the limits of the component values.



TLC7528C, TLC7528E, TLC7528I
DUAL 8-BIT MULTIPLYING
DIGITAL-TO-ANALOG CONVERTERS

SLAS062E – JANUARY 1987 – REVISED NOVEMBER 2008

APPLICATION INFORMATION

voltage-mode operation

It is possible to operate the current multiplying D/A converter of these devices in a voltage mode. In the voltage mode, a fixed voltage is placed on the current output terminal. The analog output voltage is then available at the reference voltage terminal. Figure 11 is an example of a current multiplying D/A that operates in the voltage mode.

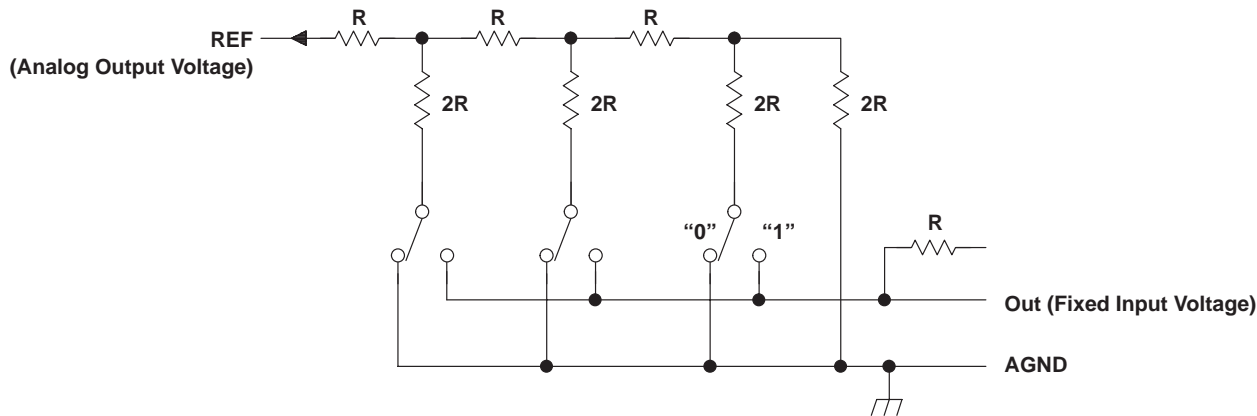

Figure 11. Voltage-Mode Operation

The following equation shows the relationship between the fixed input voltage and the analog output voltage:

$$V_O = V_I (D/256)$$

Where:

- V_O = analog output voltage
- V_I = fixed input voltage (must not be forced below 0V.)
- D = digital input code converted to decimal

In voltage-mode operation, these devices meet the following specification:

PARAMETER	TEST CONDITIONS	MIN	MAX	UNIT
Linearity error at REFA or REFB	$V_{DD} = 5V$, $OUTA$ or $OUTB$ at 2.5V, $T_A = +25^\circ C$		1	LSB

Revision History

DATE	REV	PAGE	SECTION	DESCRIPTION
11/08	E	13	Application Information	Corrected Figure 10.
6/07	D	Front Page	—	Deleted Available Options table.
		3	—	Inserted Package/Ordering information.

NOTE: Page numbers for previous revisions may differ from page numbers in the current version.

PACKAGING INFORMATION

Orderable Device	Status (1)	Package Type	Package Drawing	Pins	Package Qty	Eco Plan (2)	Lead finish/ Ball material (6)	MSL Peak Temp (3)	Op Temp (°C)	Device Marking (4/5)	Samples
TLC7528CDW	ACTIVE	SOIC	DW	20	25	RoHS & Green	NIPDAU	Level-1-260C-UNLIM	0 to 70	TLC7528C	Samples
TLC7528CDWR	ACTIVE	SOIC	DW	20	2000	RoHS & Green	NIPDAU	Level-1-260C-UNLIM	0 to 70	TLC7528C	Samples
TLC7528CDWRG4	ACTIVE	SOIC	DW	20	2000	RoHS & Green	NIPDAU	Level-1-260C-UNLIM	0 to 70	TLC7528C	Samples
TLC7528CFN	LIFEBUY	PLCC	FN	20	46	RoHS & Green	SN	Level-1-260C-UNLIM	0 to 70	TLC7528C	
TLC7528CFNR	LIFEBUY	PLCC	FN	20	1000	RoHS & Green	SN	Level-1-260C-UNLIM	0 to 70	TLC7528C	
TLC7528CN	ACTIVE	PDIP	N	20	20	RoHS & Non-Green	NIPDAU	N / A for Pkg Type	0 to 70	TLC7528CN	Samples
TLC7528CNS	ACTIVE	SO	NS	20	40	RoHS & Green	NIPDAU	Level-1-260C-UNLIM	0 to 70	TLC7528	Samples
TLC7528CNSR	ACTIVE	SO	NS	20	2000	RoHS & Green	NIPDAU	Level-1-260C-UNLIM	0 to 70	TLC7528	Samples
TLC7528CPW	ACTIVE	TSSOP	PW	20	70	RoHS & Green	NIPDAU	Level-1-260C-UNLIM	0 to 70	TLC7528C	Samples
TLC7528CPWR	ACTIVE	TSSOP	PW	20	2000	RoHS & Green	NIPDAU	Level-1-260C-UNLIM	0 to 70	TLC7528C	Samples
TLC7528EDW	ACTIVE	SOIC	DW	20	25	RoHS & Green	NIPDAU	Level-1-260C-UNLIM	-40 to 85	TLC7528E	Samples
TLC7528EDWG4	ACTIVE	SOIC	DW	20	25	RoHS & Green	NIPDAU	Level-1-260C-UNLIM	-40 to 85	TLC7528E	Samples
TLC7528EDWR	ACTIVE	SOIC	DW	20	2000	RoHS & Green	NIPDAU	Level-1-260C-UNLIM	-40 to 85	TLC7528E	Samples
TLC7528EN	ACTIVE	PDIP	N	20	20	RoHS & Non-Green	NIPDAU	N / A for Pkg Type	-40 to 85	TLC7528EN	Samples
TLC7528IDW	ACTIVE	SOIC	DW	20	25	RoHS & Green	NIPDAU	Level-1-260C-UNLIM	-25 to 85	TLC7528I	Samples
TLC7528IDWR	ACTIVE	SOIC	DW	20	2000	RoHS & Green	NIPDAU	Level-1-260C-UNLIM	-25 to 85	TLC7528I	Samples
TLC7528IFN	LIFEBUY	PLCC	FN	20	46	RoHS & Green	SN	Level-1-260C-UNLIM	-25 to 85	TLC7528I	
TLC7528IFNG3	LIFEBUY	PLCC	FN	20	46	RoHS & Green	SN	Level-1-260C-UNLIM	-25 to 85	TLC7528I	
TLC7528IN	ACTIVE	PDIP	N	20	20	RoHS & Non-Green	NIPDAU	N / A for Pkg Type	-25 to 85	TLC7528IN	Samples
TLC7528IPW	ACTIVE	TSSOP	PW	20	70	RoHS & Green	NIPDAU	Level-1-260C-UNLIM	-25 to 85	TLC7528I	Samples
TLC7528IPWR	ACTIVE	TSSOP	PW	20	2000	RoHS & Green	NIPDAU	Level-1-260C-UNLIM	-25 to 85	TLC7528I	Samples

(1) The marketing status values are defined as follows:

ACTIVE: Product device recommended for new designs.

LIFEBUY: TI has announced that the device will be discontinued, and a lifetime-buy period is in effect.

NRND: Not recommended for new designs. Device is in production to support existing customers, but TI does not recommend using this part in a new design.

PREVIEW: Device has been announced but is not in production. Samples may or may not be available.

OBSOLETE: TI has discontinued the production of the device.

(2) **RoHS:** TI defines "RoHS" to mean semiconductor products that are compliant with the current EU RoHS requirements for all 10 RoHS substances, including the requirement that RoHS substance do not exceed 0.1% by weight in homogeneous materials. Where designed to be soldered at high temperatures, "RoHS" products are suitable for use in specified lead-free processes. TI may reference these types of products as "Pb-Free".

RoHS Exempt: TI defines "RoHS Exempt" to mean products that contain lead but are compliant with EU RoHS pursuant to a specific EU RoHS exemption.

Green: TI defines "Green" to mean the content of Chlorine (Cl) and Bromine (Br) based flame retardants meet JS709B low halogen requirements of ≤ 1000 ppm threshold. Antimony trioxide based flame retardants must also meet the ≤ 1000 ppm threshold requirement.

(3) MSL, Peak Temp. - The Moisture Sensitivity Level rating according to the JEDEC industry standard classifications, and peak solder temperature.

(4) There may be additional marking, which relates to the logo, the lot trace code information, or the environmental category on the device.

(5) Multiple Device Markings will be inside parentheses. Only one Device Marking contained in parentheses and separated by a "~" will appear on a device. If a line is indented then it is a continuation of the previous line and the two combined represent the entire Device Marking for that device.

(6) Lead finish/Ball material - Orderable Devices may have multiple material finish options. Finish options are separated by a vertical ruled line. Lead finish/Ball material values may wrap to two lines if the finish value exceeds the maximum column width.

Important Information and Disclaimer: The information provided on this page represents TI's knowledge and belief as of the date that it is provided. TI bases its knowledge and belief on information provided by third parties, and makes no representation or warranty as to the accuracy of such information. Efforts are underway to better integrate information from third parties. TI has taken and continues to take reasonable steps to provide representative and accurate information but may not have conducted destructive testing or chemical analysis on incoming materials and chemicals. TI and TI suppliers consider certain information to be proprietary, and thus CAS numbers and other limited information may not be available for release.

In no event shall TI's liability arising out of such information exceed the total purchase price of the TI part(s) at issue in this document sold by TI to Customer on an annual basis.

TAPE AND REEL INFORMATION

QUADRANT ASSIGNMENTS FOR PIN 1 ORIENTATION IN TAPE

*All dimensions are nominal

Device	Package Type	Package Drawing	Pins	SPQ	Reel Diameter (mm)	Reel Width W1 (mm)	A0 (mm)	B0 (mm)	K0 (mm)	P1 (mm)	W (mm)	Pin1 Quadrant
TLC7528CDWR	SOIC	DW	20	2000	330.0	24.4	10.8	13.3	2.7	12.0	24.0	Q1
TLC7528CNSR	SO	NS	20	2000	330.0	24.4	8.4	13.0	2.5	12.0	24.0	Q1
TLC7528CPWR	TSSOP	PW	20	2000	330.0	16.4	6.95	7.1	1.6	8.0	16.0	Q1
TLC7528EDWR	SOIC	DW	20	2000	330.0	24.4	10.8	13.3	2.7	12.0	24.0	Q1
TLC7528IDWR	SOIC	DW	20	2000	330.0	24.4	10.8	13.3	2.7	12.0	24.0	Q1
TLC7528IPWR	TSSOP	PW	20	2000	330.0	16.4	6.95	7.1	1.6	8.0	16.0	Q1

TAPE AND REEL BOX DIMENSIONS

*All dimensions are nominal

Device	Package Type	Package Drawing	Pins	SPQ	Length (mm)	Width (mm)	Height (mm)
TLC7528CDWR	SOIC	DW	20	2000	367.0	367.0	45.0
TLC7528CNSR	SO	NS	20	2000	367.0	367.0	45.0
TLC7528CPWR	TSSOP	PW	20	2000	356.0	356.0	35.0
TLC7528EDWR	SOIC	DW	20	2000	367.0	367.0	45.0
TLC7528IDWR	SOIC	DW	20	2000	367.0	367.0	45.0
TLC7528IPWR	TSSOP	PW	20	2000	356.0	356.0	35.0

TUBE

*All dimensions are nominal

Device	Package Name	Package Type	Pins	SPQ	L (mm)	W (mm)	T (μm)	B (mm)
TLC7528CDW	DW	SOIC	20	25	507	12.83	5080	6.6
TLC7528CFN	FN	PLCC	20	46	497.33	10.69	5080	0
TLC7528CN	N	PDIP	20	20	506	13.97	11230	4.32
TLC7528CNS	NS	SOP	20	40	530	10.5	4000	4.1
TLC7528CPW	PW	TSSOP	20	70	530	10.2	3600	3.5
TLC7528EDW	DW	SOIC	20	25	507	12.83	5080	6.6
TLC7528EDWG4	DW	SOIC	20	25	507	12.83	5080	6.6
TLC7528EN	N	PDIP	20	20	506	13.97	11230	4.32
TLC7528IDW	DW	SOIC	20	25	507	12.83	5080	6.6
TLC7528IFN	FN	PLCC	20	46	497.33	10.69	5080	0
TLC7528IFNG3	FN	PLCC	20	46	497.33	10.69	5080	0
TLC7528IN	N	PDIP	20	20	506	13.97	11230	4.32
TLC7528IPW	PW	TSSOP	20	70	530	10.2	3600	3.5

MECHANICAL DATA

NS (R-PDSO-G**)

PLASTIC SMALL-OUTLINE PACKAGE

14-PINS SHOWN



- NOTES:
- A. All linear dimensions are in millimeters.
 - B. This drawing is subject to change without notice.
 - C. Body dimensions do not include mold flash or protrusion, not to exceed 0,15.

FN 20

GENERIC PACKAGE VIEW

PLCC - 4.57 mm max height

PLASTIC CHIP CARRIER

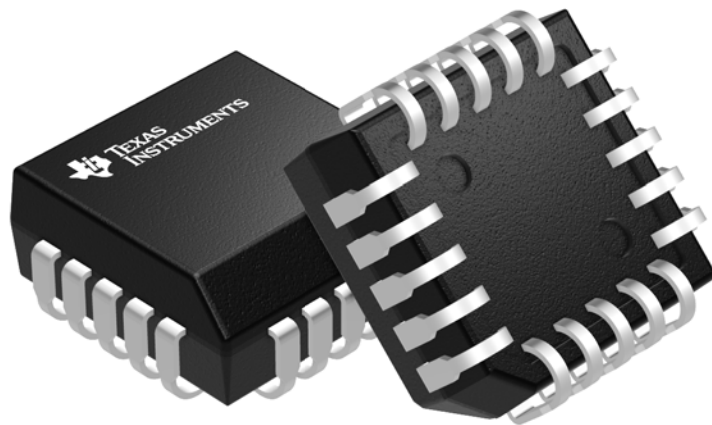

Images above are just a representation of the package family, actual package may vary.
Refer to the product data sheet for package details.

4040005-2/C



PACKAGE OUTLINE

FN0020A

PLCC - 4.57 mm max height

PLASTIC CHIP CARRIER

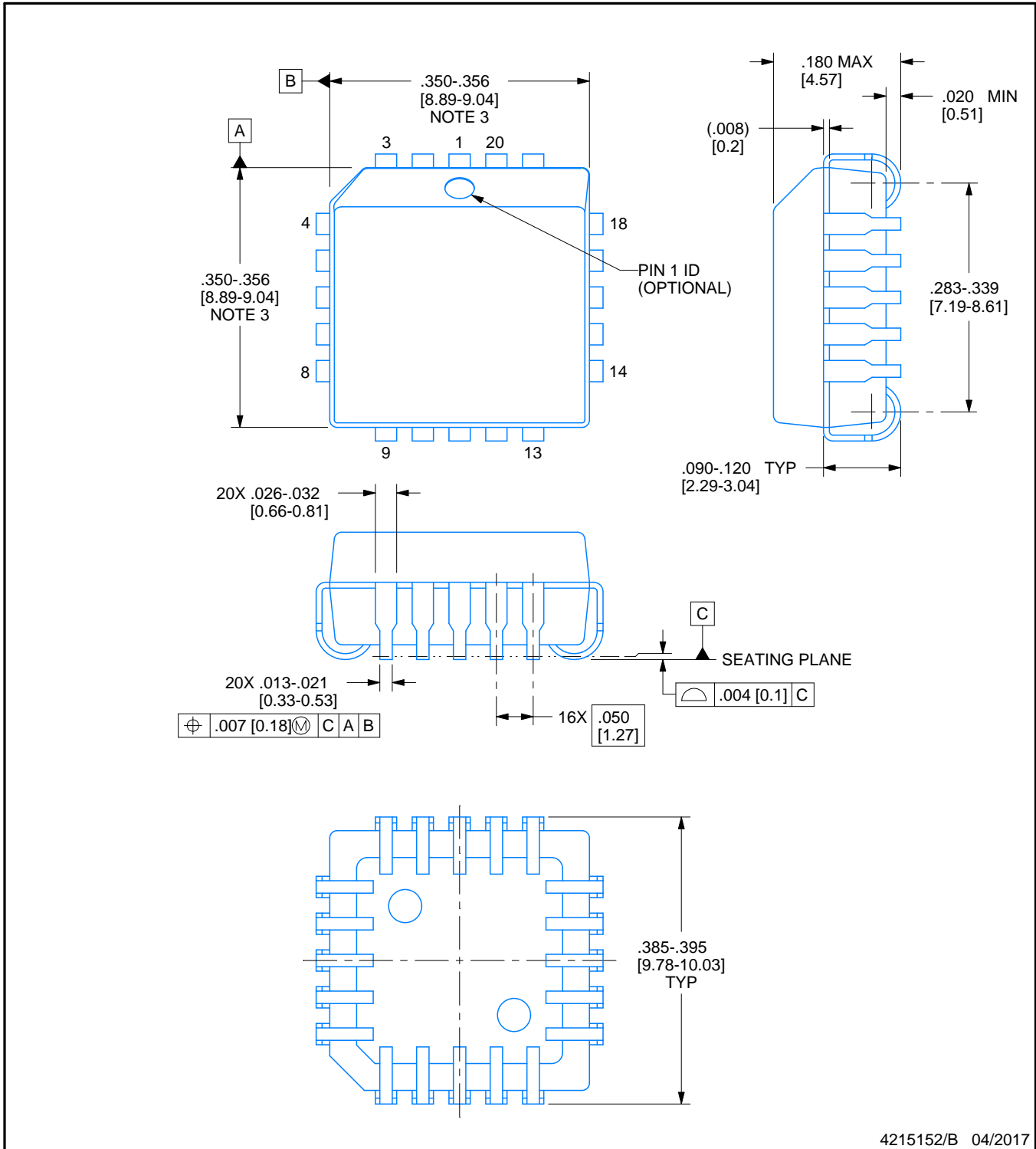

4215152/B 04/2017

NOTES:

1. All linear dimensions are in inches. Any dimensions in brackets are in millimeters. Any dimensions in parenthesis are for reference only. Controlling dimensions are in inches. Dimensioning and tolerancing per ASME Y14.5M.
2. This drawing is subject to change without notice.
3. Dimension does not include mold protrusion. Maximum allowable mold protrusion .01 in [0.25 mm] per side.
4. Reference JEDEC registration MS-018.

EXAMPLE BOARD LAYOUT

FN0020A

PLCC - 4.57 mm max height

PLASTIC CHIP CARRIER

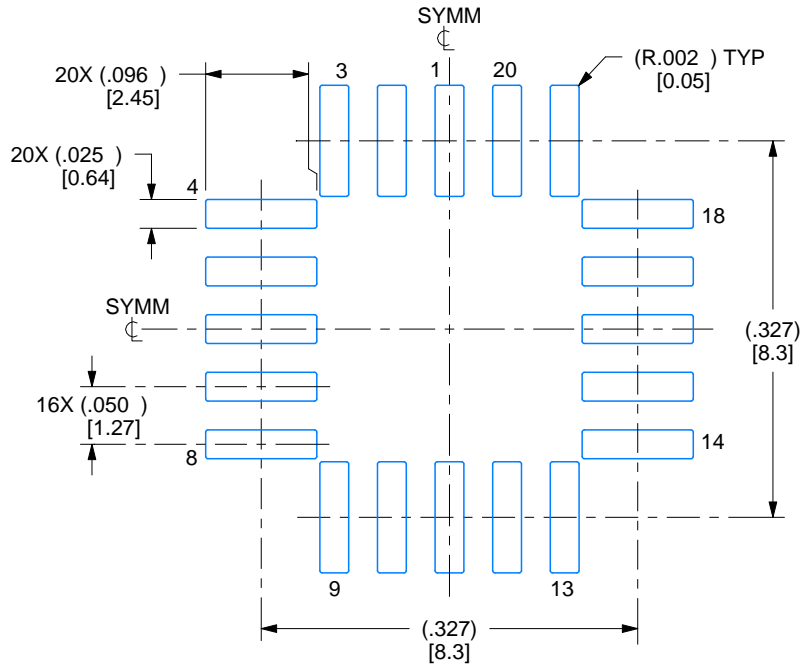

LAND PATTERN EXAMPLE
EXPOSED METAL SHOWN
SCALE:6X

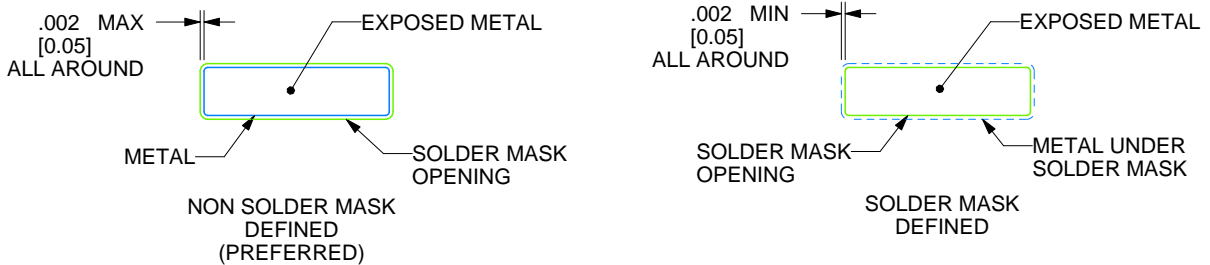

SOLDER MASK DETAILS

4215152/B 04/2017

NOTES: (continued)

- Publication IPC-7351 may have alternate designs.
- Solder mask tolerances between and around signal pads can vary based on board fabrication site.

EXAMPLE STENCIL DESIGN

FN0020A

PLCC - 4.57 mm max height

PLASTIC CHIP CARRIER

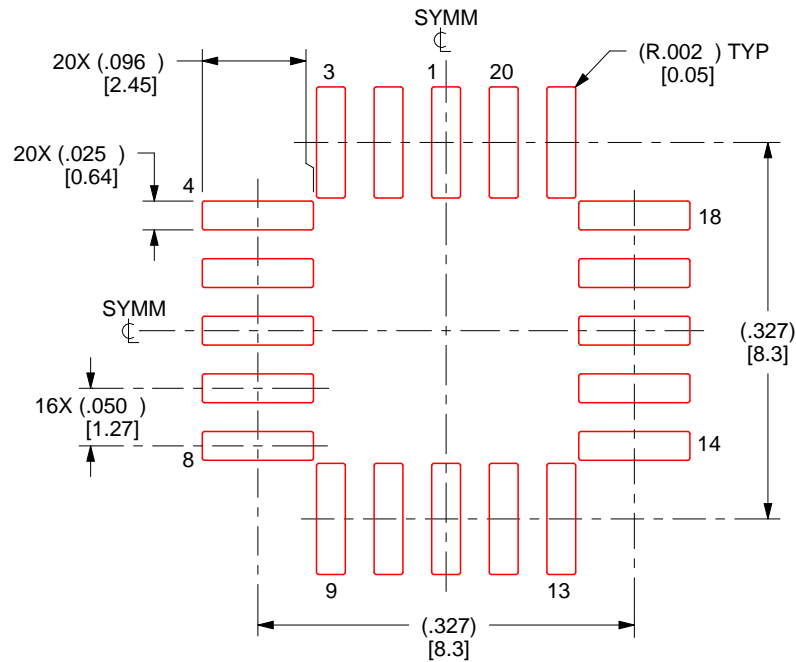

SOLDER PASTE EXAMPLE
BASED ON 0.125 mm THICK STENCIL
SCALE:6X

4215152/B 04/2017

NOTES: (continued)

7. Laser cutting apertures with trapezoidal walls and rounded corners may offer better paste release. IPC-7525 may have alternate design recommendations.
8. Board assembly site may have different recommendations for stencil design.

N (R-PDIP-T**)

PLASTIC DUAL-IN-LINE PACKAGE

16 PINS SHOWN



- NOTES:
- A. All linear dimensions are in inches (millimeters).
 - B. This drawing is subject to change without notice.
 - Falls within JEDEC MS-001, except 18 and 20 pin minimum body length (Dim A).
 - The 20 pin end lead shoulder width is a vendor option, either half or full width.

DW0020A



PACKAGE OUTLINE

SOIC - 2.65 mm max height

SOIC

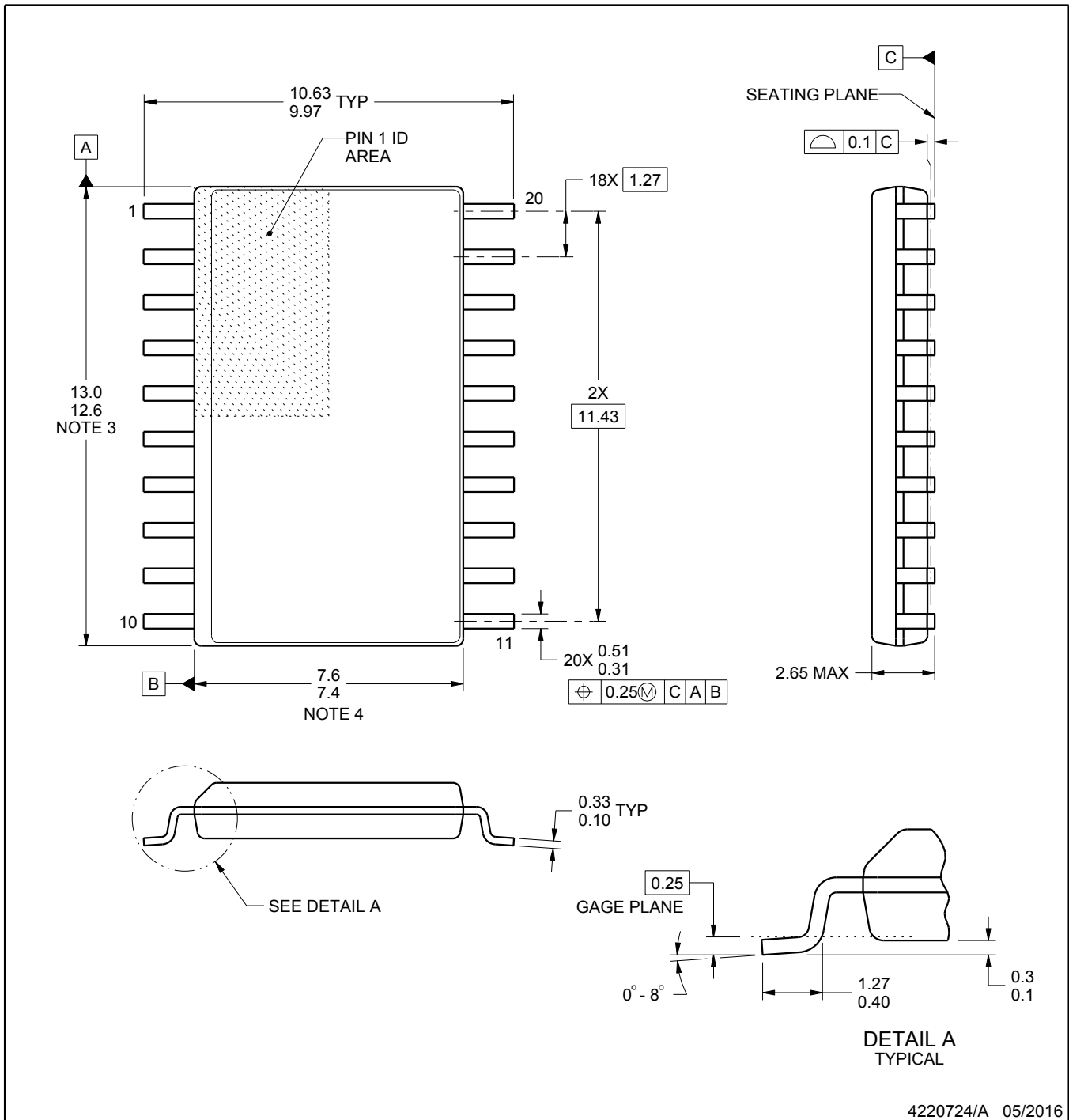

4220724/A 05/2016

NOTES:

1. All linear dimensions are in millimeters. Dimensions in parenthesis are for reference only. Dimensioning and tolerancing per ASME Y14.5M.
2. This drawing is subject to change without notice.
3. This dimension does not include mold flash, protrusions, or gate burrs. Mold flash, protrusions, or gate burrs shall not exceed 0.15 mm per side.
4. This dimension does not include interlead flash. Interlead flash shall not exceed 0.43 mm per side.
5. Reference JEDEC registration MS-013.

EXAMPLE BOARD LAYOUT

DW0020A

SOIC - 2.65 mm max height

SOIC



LAND PATTERN EXAMPLE
SCALE:6X

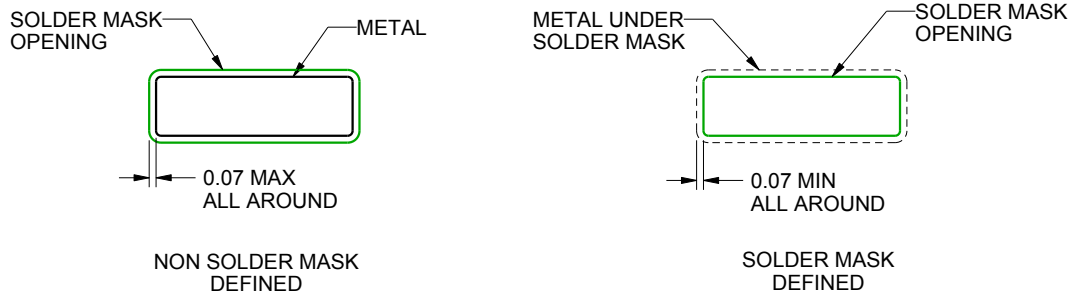

SOLDER MASK DETAILS

4220724/A 05/2016

NOTES: (continued)

- 6. Publication IPC-7351 may have alternate designs.
- 7. Solder mask tolerances between and around signal pads can vary based on board fabrication site.

EXAMPLE STENCIL DESIGN

DW0020A

SOIC - 2.65 mm max height

SOIC

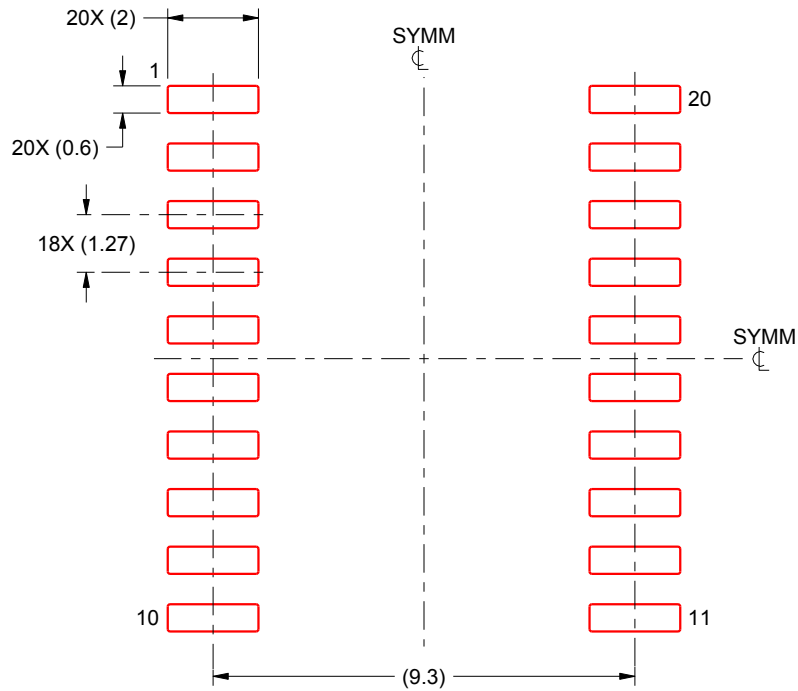

SOLDER PASTE EXAMPLE
BASED ON 0.125 mm THICK STENCIL
SCALE:6X

4220724/A 05/2016

NOTES: (continued)

8. Laser cutting apertures with trapezoidal walls and rounded corners may offer better paste release. IPC-7525 may have alternate design recommendations.
9. Board assembly site may have different recommendations for stencil design.



4220206/A 02/2017

NOTES:

1. All linear dimensions are in millimeters. Any dimensions in parenthesis are for reference only. Dimensioning and tolerancing per ASME Y14.5M.
2. This drawing is subject to change without notice.
3. This dimension does not include mold flash, protrusions, or gate burrs. Mold flash, protrusions, or gate burrs shall not exceed 0.15 mm per side.
4. This dimension does not include interlead flash. Interlead flash shall not exceed 0.25 mm per side.
5. Reference JEDEC registration MO-153.

EXAMPLE BOARD LAYOUT

PW0020A

TSSOP - 1.2 mm max height

SMALL OUTLINE PACKAGE



LAND PATTERN EXAMPLE
EXPOSED METAL SHOWN
SCALE: 10X



SOLDER MASK DETAILS

4220206/A 02/2017

NOTES: (continued)

6. Publication IPC-7351 may have alternate designs.
7. Solder mask tolerances between and around signal pads can vary based on board fabrication site.

EXAMPLE STENCIL DESIGN

PW0020A

TSSOP - 1.2 mm max height

SMALL OUTLINE PACKAGE



SOLDER PASTE EXAMPLE
BASED ON 0.125 mm THICK STENCIL
SCALE: 10X

4220206/A 02/2017

NOTES: (continued)

8. Laser cutting apertures with trapezoidal walls and rounded corners may offer better paste release. IPC-7525 may have alternate design recommendations.
9. Board assembly site may have different recommendations for stencil design.

PW (R-PDSO-G20)

PLASTIC SMALL OUTLINE

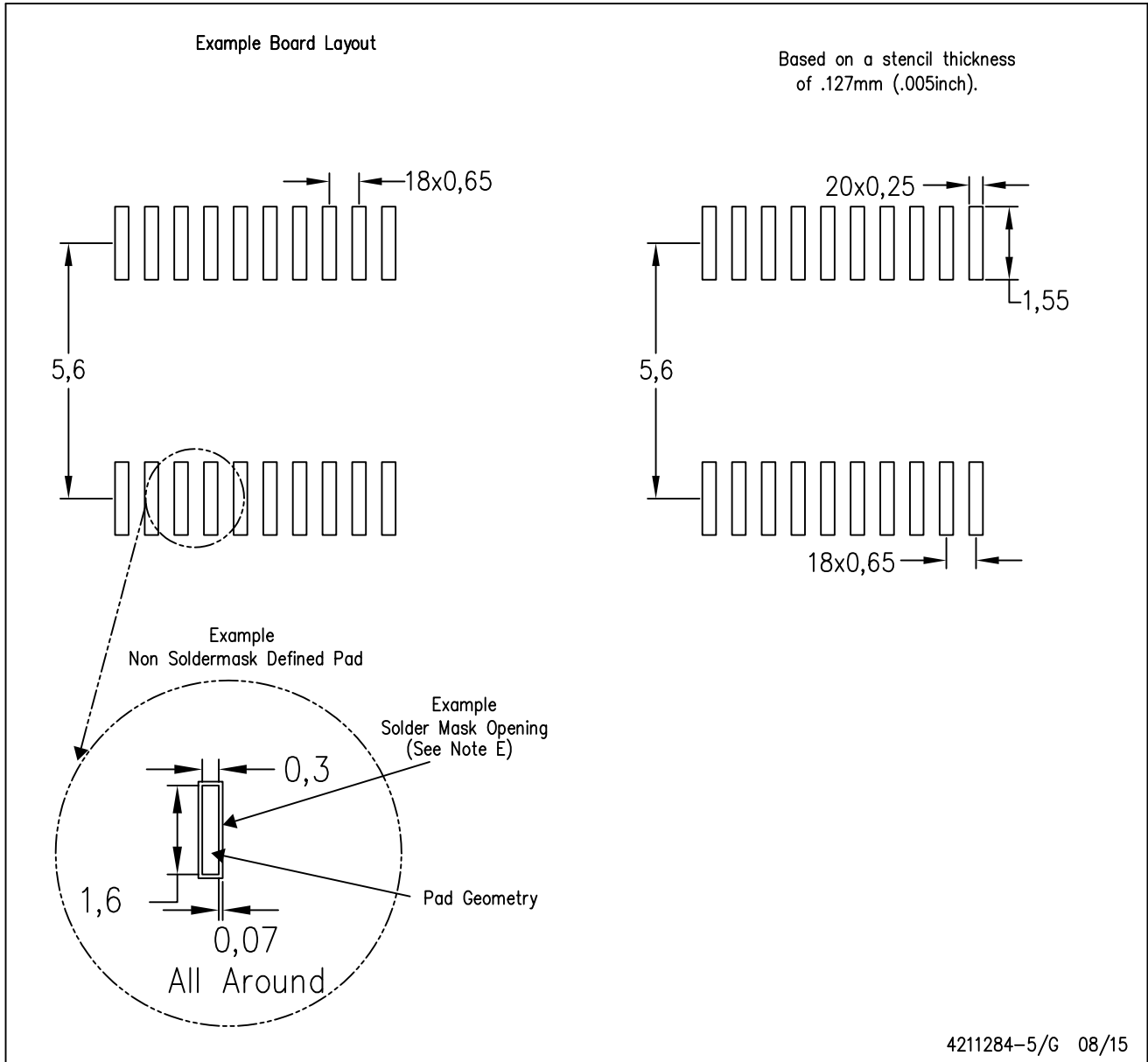

- NOTES:
- A. All linear dimensions are in millimeters.
 - B. This drawing is subject to change without notice.
 - C. Publication IPC-7351 is recommended for alternate design.
 - D. Laser cutting apertures with trapezoidal walls and also rounding corners will offer better paste release. Customers should contact their board assembly site for stencil design recommendations. Refer to IPC-7525 for other stencil recommendations.
 - E. Customers should contact their board fabrication site for solder mask tolerances between and around signal pads.

IMPORTANT NOTICE AND DISCLAIMER

TI PROVIDES TECHNICAL AND RELIABILITY DATA (INCLUDING DATA SHEETS), DESIGN RESOURCES (INCLUDING REFERENCE DESIGNS), APPLICATION OR OTHER DESIGN ADVICE, WEB TOOLS, SAFETY INFORMATION, AND OTHER RESOURCES "AS IS" AND WITH ALL FAULTS, AND DISCLAIMS ALL WARRANTIES, EXPRESS AND IMPLIED, INCLUDING WITHOUT LIMITATION ANY IMPLIED WARRANTIES OF MERCHANTABILITY, FITNESS FOR A PARTICULAR PURPOSE OR NON-INFRINGEMENT OF THIRD PARTY INTELLECTUAL PROPERTY RIGHTS.

These resources are intended for skilled developers designing with TI products. You are solely responsible for (1) selecting the appropriate TI products for your application, (2) designing, validating and testing your application, and (3) ensuring your application meets applicable standards, and any other safety, security, regulatory or other requirements.

These resources are subject to change without notice. TI grants you permission to use these resources only for development of an application that uses the TI products described in the resource. Other reproduction and display of these resources is prohibited. No license is granted to any other TI intellectual property right or to any third party intellectual property right. TI disclaims responsibility for, and you will fully indemnify TI and its representatives against, any claims, damages, costs, losses, and liabilities arising out of your use of these resources.

TI's products are provided subject to [TI's Terms of Sale](#) or other applicable terms available either on [ti.com](https://www.ti.com) or provided in conjunction with such TI products. TI's provision of these resources does not expand or otherwise alter TI's applicable warranties or warranty disclaimers for TI products.

TI objects to and rejects any additional or different terms you may have proposed.

Mailing Address: Texas Instruments, Post Office Box 655303, Dallas, Texas 75265
Copyright © 2023, Texas Instruments Incorporated