

# SN74LVC4245A Octal Bus Transceiver and 3.3-V to 5-V Shifter With 3-State Outputs

## 1 Features

- Bidirectional voltage translator
- 5.5 V on A port and 2.7 V to 3.6 V on B port
- Control inputs  $V_{IH}/V_{IL}$  levels are referenced to  $V_{CCA}$  voltage
- Latch-up performance exceeds 250 mA per JESD 17
- ESD protection exceeds JESD 22
  - 2000-V Human-Body Model
  - 1000-V Charged-Device Model

## 2 Applications

- ATCA solutions
- CPAP machines
- [Cameras: surveillance analog](#)
- Chemical or gas sensors
- CT scanners
- [DLP 3D machine vision and optical networking](#)
- [Digital signage](#)
- [ECGs: electrocardiograms](#)
- Field transmitters: pressure sensors and temperature sensors
- High-speed data acquisition and generation
- HMI (human machine interface)
- [RF4CE remote controls](#)
- [Server motherboards](#)
- [Software defined radios \(SDR\)](#)
- [Wireless LAN cards and data access cards](#)
- [X-ray: medical, dental, and baggage scanners](#)

## 3 Description

This 8-bit (octal) noninverting bus transceiver contains two separate supply rails; B port has  $V_{CCB}$ , which is set at 3.3 V, and A port has  $V_{CCA}$ , which is set at 5 V. This allows for translation from a 3.3-V to a 5-V environment, and vice versa.

The SN74LVC4245A device is designed for asynchronous communication between data buses. The device transmits data from the A bus to the B bus or from the B bus to the A bus, depending on the logic level at the direction-control (DIR) input. The output-enable ( $\overline{OE}$ ) input can be used to disable the device so the buses are effectively isolated. The control circuitry (DIR,  $\overline{OE}$ ) is powered by  $V_{CCA}$ .

The SN74LVC4245A device terminal out allows the designer to switch to a normal all-3.3-V or all-5-V 20-terminal SN74LVC4245 device without board re-layout. The designer uses the data paths for pins 2–11 and 14–23 of the SN74LVC4245A device to align with the conventional '245 terminal out.

### Package Information<sup>(1)</sup>

PART NUMBER	PACKAGE	BODY SIZE (NOM)
SN74LVC4245A	DB (SSOP, 24)	8.20 mm × 5.30 mm
	DW (SOIC, 24)	15.40 mm × 7.50 mm
	PW (TSSOP, 24)	7.80 mm × 4.40 mm

(1) For all available packages, see the orderable addendum at the end of the data sheet.

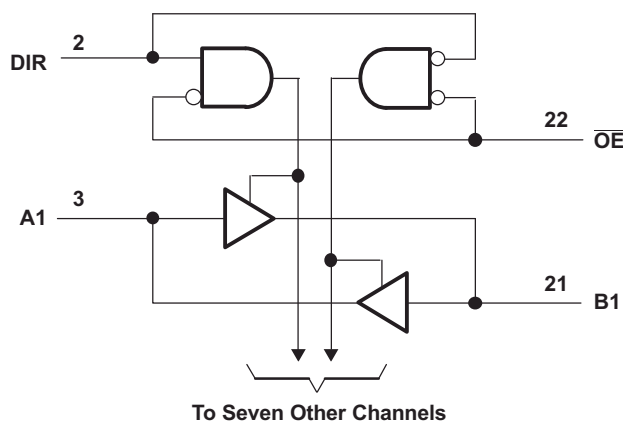

**Simplified Schematic**



## Table of Contents

<b>1 Features</b> .....	1	8.1 Overview.....	10
<b>2 Applications</b> .....	1	8.2 Functional Block Diagram.....	10
<b>3 Description</b> .....	1	8.3 Feature Description.....	10
<b>4 Revision History</b> .....	2	8.4 Device Functional Modes.....	10
<b>5 Pin Configuration and Functions</b> .....	3	<b>9 Application and Implementation</b> .....	11
<b>6 Specifications</b> .....	4	9.1 Application Information.....	11
6.1 Absolute Maximum Ratings.....	4	9.2 Typical Application.....	11
6.2 Absolute Maximum Ratings.....	4	<b>10 Power Supply Recommendations</b> .....	13
6.3 ESD Ratings.....	4	10.1 Power-Up Consideration.....	13
6.4 Recommended Operating Conditions.....	5	<b>11 Layout</b> .....	13
6.5 Recommended Operating Conditions.....	5	11.1 Layout Guidelines.....	13
6.6 Thermal Information.....	5	11.2 Layout Example.....	13
6.7 Electrical Characteristics.....	6	<b>12 Device and Documentation Support</b> .....	14
6.8 Electrical Characteristics.....	6	12.1 Documentation Support.....	14
6.9 Switching Characteristics.....	7	12.2 Receiving Notification of Documentation Updates..	14
6.10 Operating Characteristics.....	7	12.3 Support Resources.....	14
6.11 Typical Characteristics.....	7	12.4 Trademarks.....	14
<b>7 Parameter Measurement Information</b> .....	8	12.5 Electrostatic Discharge Caution.....	14
7.1 A Port.....	8	12.6 Glossary.....	14
7.2 B Port.....	9	<b>13 Mechanical, Packaging, and Orderable Information</b> .....	14
<b>8 Detailed Description</b> .....	10		

## 4 Revision History

<b>Changes from Revision I (January 2015) to Revision J (December 2022)</b>	<b>Page</b>
• Updated the numbering format for tables, figures, and cross-references throughout the document.....	1
• Updated thermals for DB and PW package.....	5
<b>Changes from Revision H (March 2005) to Revision I (January 2015)</b>	<b>Page</b>
• Added <i>Applications</i> , <i>Device Information</i> table, <i>Pin Functions</i> table, <i>ESD Ratings</i> table, <i>Thermal Information</i> table, <i>Typical Characteristics</i> , <i>Feature Description</i> section, <i>Device Functional Modes</i> , <i>Application and Implementation</i> section, <i>Power Supply Recommendations</i> section, <i>Layout</i> section, <i>Device and Documentation Support</i> section, and <i>Mechanical, Packaging, and Orderable Information</i> section.....	1
• Deleted <i>Ordering Information</i> table.....	1

## 5 Pin Configuration and Functions

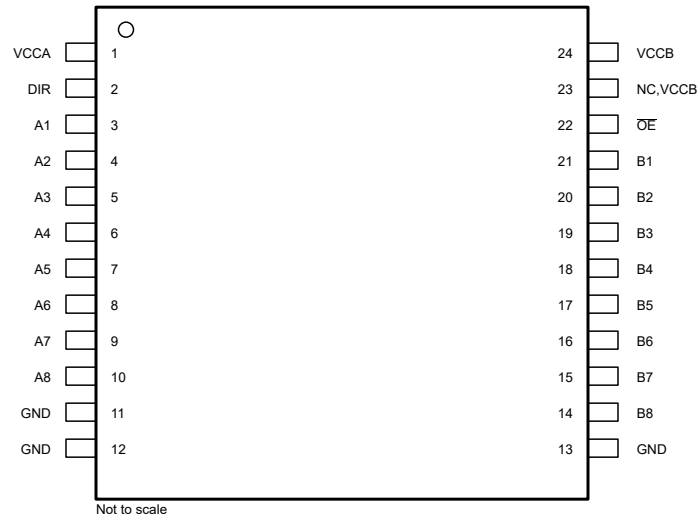

**Figure 5-1. DB, DW, or PW Package, SOP, TSSOP, (Top View)**

**Table 5-1. Pin Functions**

PIN		TYPE <sup>(1)</sup>	DESCRIPTION
NAME	NO.		
V <sub>CCA</sub>	1	—	Power supply for side A
DIR	2	I	Direction control
A1	3	I/O	Transceiver I/O pin
A2	4	I/O	Transceiver I/O pin
A3	5	I/O	Transceiver I/O pin
A4	6	I/O	Transceiver I/O pin
A5	7	I/O	Transceiver I/O pin
A6	8	I/O	Transceiver I/O pin
A7	9	I/O	Transceiver I/O pin
A8	10	I/O	Transceiver I/O pin
GND	11	—	Ground
GND	12	—	Ground
GND	13	—	Ground
B8	14	I/O	Transceiver I/O pin
B7	15	I/O	Transceiver I/O pin
B6	16	I/O	Transceiver I/O pin
B5	17	I/O	Transceiver I/O pin
B4	18	I/O	Transceiver I/O pin
B3	19	I/O	Transceiver I/O pin
B2	20	I/O	Transceiver I/O pin
B1	21	I/O	Transceiver I/O pin
$\overline{OE}$	22	I	Output Enable
V <sub>CCB</sub>	23	—	Power supply for side B
V <sub>CCB</sub>	24	—	Power supply for side B

(1) I = input, O = output

## 6 Specifications

### 6.1 Absolute Maximum Ratings

over operating free-air temperature range for  $V_{CCA} = 4.5\text{ V to }5.5\text{ V}$  (unless otherwise noted)<sup>(1)</sup>

		MIN	MAX	UNIT
$V_{CCA}$	Supply voltage range	-0.5	6.5	V
$V_I$	Input voltage range	A port <sup>(2)</sup>	$V_{CCA} + 0.5$	V
		Control inputs	6	
$V_O$	Output voltage range	-0.5	$V_{CCA} + 0.5$	V
$I_{IK}$	Input clamp current	$V_I < 0$	-50	mA
$I_{OK}$	Output clamp current	$V_O < 0$	-50	mA
$I_O$	Continuous output current		±50	mA
	Continuous current through each $V_{CCA}$ or GND		±100	
$T_{stg}$	Storage temperature range	-65	150	°C

- (1) Stresses beyond those listed under *Absolute Maximum Ratings* may cause permanent damage to the device. These are stress ratings only, and functional operation of the device at these or any other conditions beyond those indicated under [Section 6.4](#) is not implied. Exposure to absolute-maximum-rated conditions for extended periods may affect device reliability.
- (2) This value is limited to 6 V maximum.

### 6.2 Absolute Maximum Ratings

over operating free-air temperature range for  $V_{CCB} = 2.7\text{ V to }3.6\text{ V}$  (unless otherwise noted)<sup>(1)</sup>

		MIN	MAX	UNIT
$V_{CCB}$	Supply voltage range	-0.5	4.6	V
$V_I$	Input voltage range	B port <sup>(2)</sup>	$V_{CCB} + 0.5$	V
$V_O$	Output voltage range	B port <sup>(2)</sup>	$V_{CCB} + 0.5$	V
$I_{IK}$	Input clamp current	$V_I < 0$	-50	mA
$I_{OK}$	Output clamp current	$V_O < 0$	-50	mA
$I_O$	Continuous output current		±50	mA
	Continuous current through $V_{CCB}$ or GND		±100	
$T_{stg}$	Storage temperature range	-65	150	°C

- (1) Stresses beyond those listed under *Absolute Maximum Ratings* may cause permanent damage to the device. These are stress ratings only, and functional operation of the device at these or any other conditions beyond those indicated under [Section 6.4](#) is not implied. Exposure to absolute-maximum-rated conditions for extended periods may affect device reliability.
- (2) This value is limited to 4.6 V maximum.

### 6.3 ESD Ratings

PARAMETER	DEFINITION	VALUE	UNIT	
$V_{(ESD)}$	Electrostatic discharge	Human body model (HBM), per ANSI/ESDA/JEDEC JS-001, all pins <sup>(1)</sup>	2000	V
		Charged device model (CDM), per JEDEC specification JESD22-C101, all pins <sup>(2)</sup>	1000	

- (1) JEDEC document JEP155 states that 500-V HBM allows safe manufacturing with a standard ESD control process.
- (2) JEDEC document JEP157 states that 250-V CDM allows safe manufacturing with a standard ESD control process.

## 6.4 Recommended Operating Conditions

for  $V_{CCA} = 4.5\text{ V to }5.5\text{ V}^{(1)}$

		MIN	MAX	UNIT
$V_{CCA}$	Supply voltage	4.5	5.5	V
$V_{IH}$	High-level input voltage	2		V
$V_{IL}$	Low-level input voltage		0.8	V
$V_{IA}$	Input voltage	0	$V_{CCA}$	V
$V_{OA}$	Output voltage	0	$V_{CCA}$	V
$I_{OH}$	High-level output current		-24	mA
$I_{OL}$	Low-level output current		24	mA
$T_A$	Operating free-air temperature	-40	85	°C

(1) All unused inputs of the device must be held at the associated  $V_{CC}$  or GND to ensure proper device operation. Refer to the TI application report, *Implications of Slow or Floating CMOS Inputs*, literature number [SCBA004](#).

## 6.5 Recommended Operating Conditions

for  $V_{CCB} = 2.7\text{ V to }3.6\text{ V}^{(1)}$

		MIN	MAX	UNIT
$V_{CCB}$	Supply voltage	2.7	3.6	V
$V_{IH}$	High-level input voltage	$V_{CCB} = 2.7\text{ V to }3.6\text{ V}$	2	V
$V_{IL}$	Low-level input voltage	$V_{CCB} = 2.7\text{ V to }3.6\text{ V}$	0.8	V
$V_{IB}$	Input voltage	0	$V_{CCB}$	V
$V_{OB}$	Output voltage	0	$V_{CCB}$	V
$I_{OH}$	High-level output current	$V_{CCB} = 2.7\text{ V}$	-12	mA
		$V_{CCB} = 3\text{ V}$	-24	
$I_{OL}$	Low-level output current	$V_{CCB} = 2.7\text{ V}$	12	mA
		$V_{CCB} = 3\text{ V}$	24	
$T_A$	Operating free-air temperature	-40	85	°C

(1) All unused inputs of the device must be held at the associated  $V_{CC}$  or GND to ensure proper device operation. Refer to the TI application report, *Implications of Slow or Floating CMOS Inputs*, literature number [SCBA004](#).

## 6.6 Thermal Information

THERMAL METRIC <sup>(1)</sup>		SN74LVC4245A		UNIT
		DB	PW	
		24 PINS		
$R_{\theta JA}$	Junction-to-ambient thermal resistance	90.7	100.6	°C/W
$R_{\theta JC(top)}$	Junction-to-case (top) thermal resistance	51.9	44.7	°C/W
$R_{\theta JB}$	Junction-to-board thermal resistance	49.7	55.8	°C/W
$\Psi_{JT}$	Junction-to-top characterization parameter	18.8	6.8	°C/W
$\Psi_{JB}$	Junction-to-board characterization parameter	49.3	55.4	°C/W

(1) For more information about traditional and new thermal metrics, see the *IC Package Thermal Metrics* application report, [SPRA953](#).

## 6.7 Electrical Characteristics

over recommended operating free-air temperature range for  $V_{CCA} = 4.5\text{ V to }5.5\text{ V}$  (unless otherwise noted)<sup>(1)</sup>

PARAMETER		TEST CONDITIONS	$V_{CCA}$	MIN	TYP <sup>(2)</sup>	MAX	UNIT
$V_{OH}$		$I_{OH} = -100\ \mu\text{A}$	4.5 V	4.3		V	
			5.5 V	5.3			
		$I_{OH} = -24\ \text{mA}$	4.5 V	3.7			
			5.5 V	4.7			
$V_{OL}$		$I_{OL} = 100\ \mu\text{A}$	4.5 V	0.2		V	
			5.5 V	0.2			
		$I_{OL} = 24\ \text{mA}$	4.5 V	0.55			
			5.5 V	0.55			
$I_I$	Control inputs	$V_I = V_{CCA}$ or GND	5.5 V			$\pm 1$	$\mu\text{A}$
$I_{OZ}$ <sup>(3)</sup>	A port	$V_O = V_{CCA}$ or GND	5.5 V			$\pm 5$	$\mu\text{A}$
$I_{CCA}$		$V_I = V_{CCA}$ or GND, $I_O = 0$	5.5 V			80	$\mu\text{A}$
$\Delta I_{CCA}$ <sup>(4)</sup>		One input at 3.4 V, Other inputs at $V_{CCA}$ or GND	5.5 V			1.5	mA
$C_i$	Control inputs	$V_I = V_{CCA}$ or GND	Open			5	pF
$C_{io}$	A port	$V_O = V_{CCA}$ or GND	5 V			11	pF

(1)  $V_{CCB} = 2.7\text{ V to }3.6\text{ V}$ .

(2) All typical values are measured at  $V_{CC} = 5\text{ V}$ ,  $T_A = 25^\circ\text{C}$ .

(3) For I/O ports, the parameter  $I_{OZ}$  includes the input leakage current.

(4) This is the increase in supply current for each input that is at one of the specified TTL voltage levels, rather than 0 V or the associated  $V_{CC}$ .

## 6.8 Electrical Characteristics

over recommended operating free-air temperature range for  $V_{CCB} = 2.7\text{ V to }3.6\text{ V}$  (unless otherwise noted)<sup>(1)</sup>

PARAMETER		TEST CONDITIONS	$V_{CCB}$	MIN	TYP <sup>(4)</sup>	MAX	UNIT
$V_{OH}$		$I_{OH} = -100\ \mu\text{A}$	2.7 V to 3.6 V	$V_{CC} - 0.2$		V	
			2.7 V	2.2			
		$I_{OH} = -12\ \text{mA}$	3 V	2.4			
			3 V	2			
$V_{OL}$		$I_{OL} = 100\ \mu\text{A}$	2.7 V to 3.6 V	0.2		V	
		$I_{OL} = 12\ \text{mA}$	2.7 V	0.4			
		$I_{OL} = 24\ \text{mA}$	3 V	0.55			
$I_{OZ}$ <sup>(2)</sup>	B port	$V_O = V_{CCB}$ or GND	3.6 V			$\pm 5$	$\mu\text{A}$
$I_{CCB}$		$V_I = V_{CCB}$ or GND, $I_O = 0$	3.6 V			50	$\mu\text{A}$
$\Delta I_{CCB}$ <sup>(3)</sup>		One input at $V_{CCB} - 0.6\text{ V}$ , Other inputs at $V_{CCB}$ or GND	2.7 V to 3.6 V			0.5	mA
$C_{io}$	B port	$V_O = V_{CCB}$ or GND	3.3 V			11	pF

(1)  $V_{CCA} = 5\text{ V} \pm 0.5\text{ V}$ .

(2) For I/O ports, the parameter  $I_{OZ}$  includes the input leakage current.

(3) This is the increase in supply current for each input that is at one of the specified TTL voltage levels, rather than 0 V or the associated  $V_{CC}$ .

(4) All typical values are measured at  $V_{CC} = 3.3\text{ V}$ ,  $T_A = 25^\circ\text{C}$ .

### 6.9 Switching Characteristics

over recommended operating free-air temperature range,  $C_L = 50$  pF (unless otherwise noted) (see Figure 7-1 and Figure 7-2)

PARAMETER	FROM (INPUT)	TO (OUTPUT)	$V_{CCA} = 5\text{ V} \pm 0.5\text{ V}$ , $V_{CCB} = 2.7\text{ V to } 3.6\text{ V}$		UNIT
			MIN	MAX	
$t_{PHL}$	A	B	1	6.3	ns
$t_{PLH}$			1	6.7	
$t_{PHL}$	B	A	1	6.1	ns
$t_{PLH}$			1	5	
$t_{PZL}$	$\overline{OE}$	A	1	9	ns
$t_{PZH}$			1	10	
$t_{PZL}$	$\overline{OE}$	B	1	10.3	ns
$t_{PZH}$			1	9.8	
$t_{PLZ}$	$\overline{OE}$	A	1	7	ns
$t_{PHZ}$			1	5.8	
$t_{PLZ}$	$\overline{OE}$	B	1	7.7	ns
$t_{PHZ}$			1	7.8	

### 6.10 Operating Characteristics

$V_{CCA} = 4.5\text{ V to } 5.5\text{ V}$ ,  $V_{CCB} = 2.7\text{ V to } 3.6\text{ V}$ ,  $T_A = 25^\circ\text{C}$

PARAMETER		TEST CONDITIONS	TYP	UNIT
$C_{pd}$	Power dissipation capacitance per transceiver	Outputs enabled	39.5	pF
		Outputs disabled	5	

### 6.11 Typical Characteristics

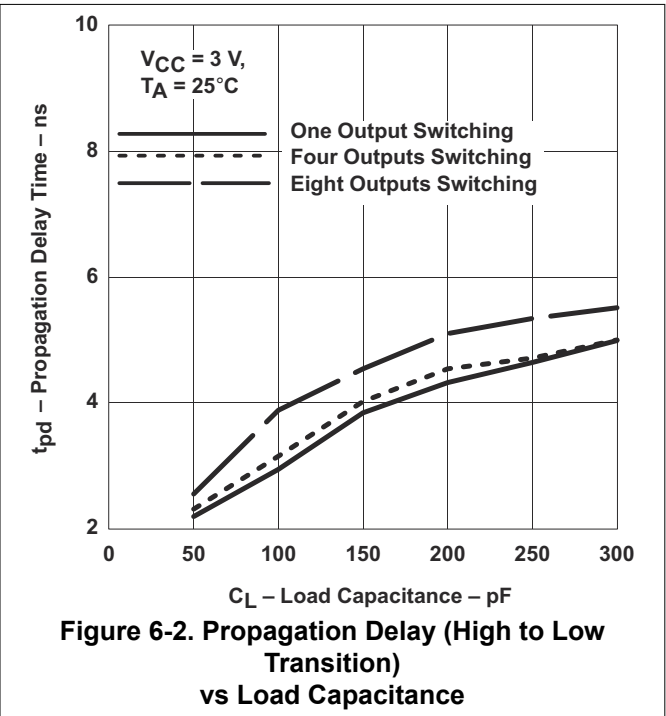
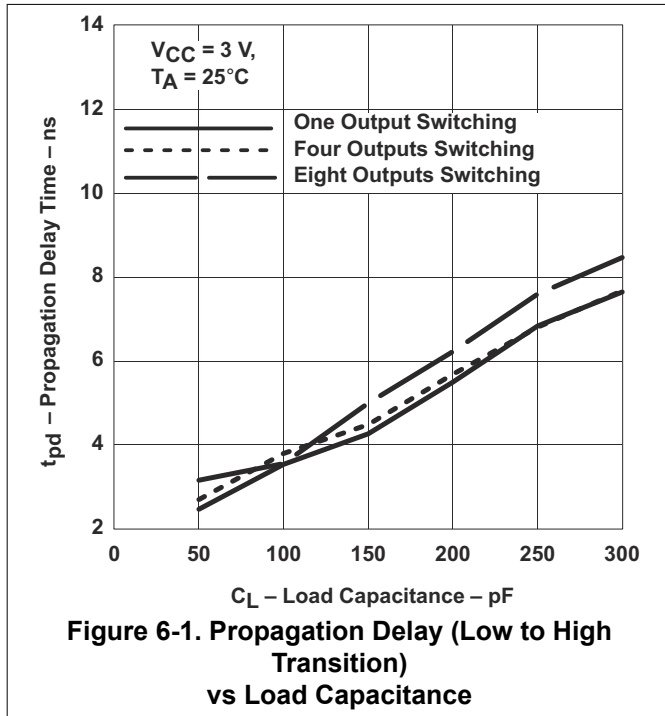

## 7 Parameter Measurement Information

### 7.1 A Port

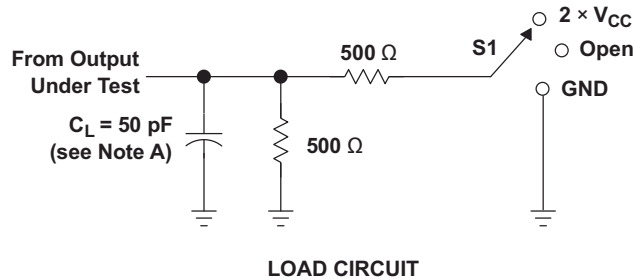

TEST	S1
$t_{PLH}/t_{PHL}$	Open
$t_{PLZ}/t_{PZL}$	2 $\times V_{CC}$
$t_{PHZ}/t_{PZH}$	GND

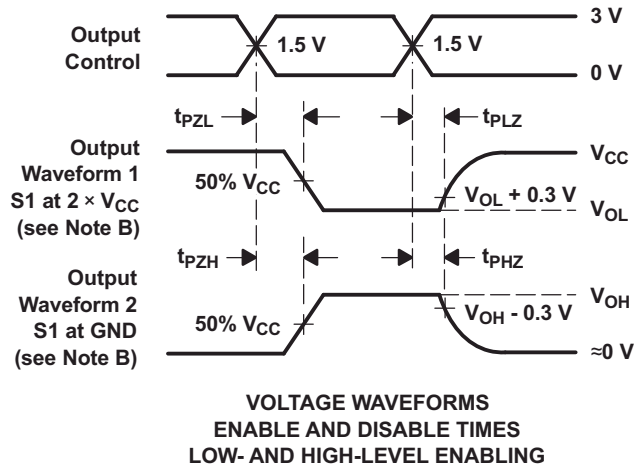
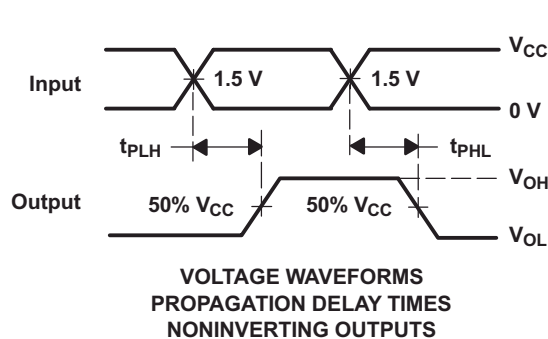
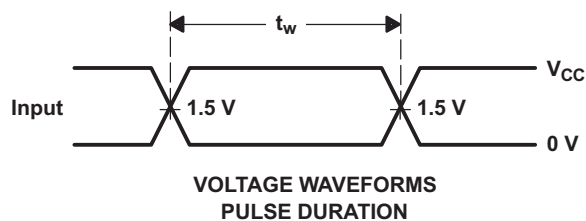

- NOTES: A.  $C_L$  includes probe and jig capacitance.  
 B. Waveform 1 is for an output with internal conditions such that the output is low, except when disabled by the output control. Waveform 2 is for an output with internal conditions such that the output is high, except when disabled by the output control.  
 C. All input pulses are supplied by generators having the following characteristics:  $PRR \leq 10 \text{ MHz}$ ,  $Z_O = 50 \Omega$ ,  $t_r \leq 2.5 \text{ ns}$ ,  $t_f \leq 2.5 \text{ ns}$ .  
 D. The outputs are measured one at a time, with one transition per measurement.  
 E. All parameters and waveforms are not applicable to all devices.

Figure 7-1. Load Circuit and Voltage Waveforms

### 7.2 B Port

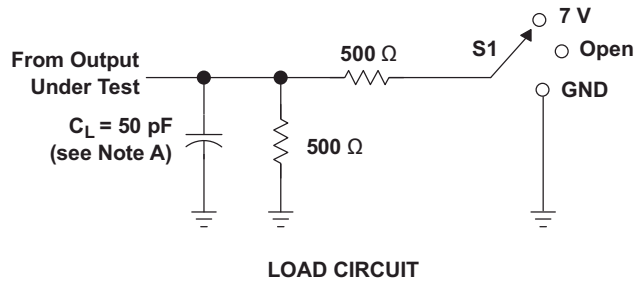

TEST	S1
$t_{PLH}/t_{PHL}$	Open
$t_{PLZ}/t_{PZL}$	7 V
$t_{PHZ}/t_{PZH}$	GND

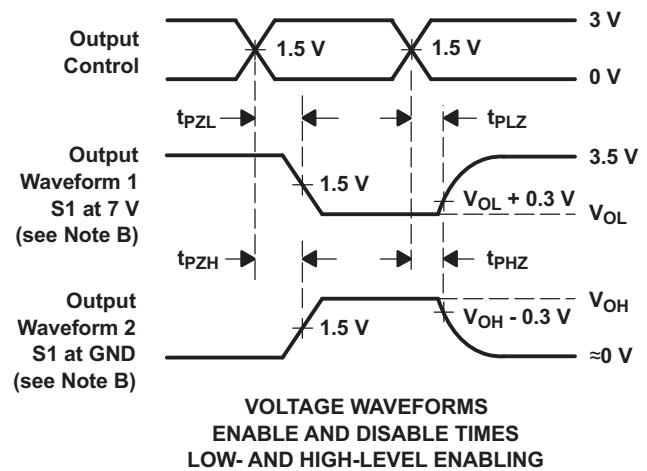
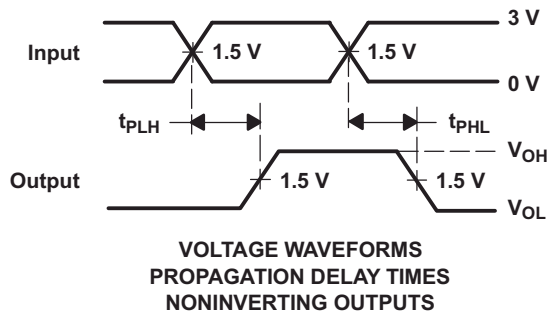
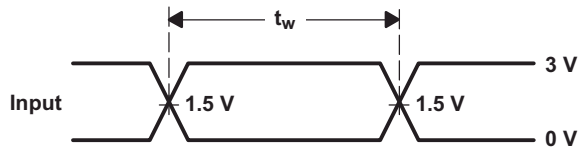

- NOTES: A.  $C_L$  includes probe and jig capacitance.  
 B. Waveform 1 is for an output with internal conditions such that the output is low, except when disabled by the output control. Waveform 2 is for an output with internal conditions such that the output is high, except when disabled by the output control.  
 C. All input pulses are supplied by generators having the following characteristics:  $PRR \leq 10 \text{ MHz}$ ,  $Z_O = 50 \Omega$ ,  $t_r \leq 2.5 \text{ ns}$ ,  $t_f \leq 2.5 \text{ ns}$ .  
 D. The outputs are measured one at a time, with one transition per measurement.  
 E. All parameters and waveforms are not applicable to all devices.

Figure 7-2. Load Circuit and Voltage Waveforms

## 8 Detailed Description

### 8.1 Overview

SN74LVC4245A is an 8-bit (octal) noninverting bus transceiver contains two separate supply rails; B port has  $V_{CCB}$ , which is set at 3.3 V, and A port has  $V_{CCA}$ , which is set at 5 V. This allows for translation from a 3.3-V to a 5-V environment, and vice versa, designed for asynchronous communication between data buses. The device transmits data from the A bus to the B bus or from the B bus to the A bus, depending on the logic level at the direction-control (DIR) input. The output-enable ( $\overline{OE}$ ) input can be used to disable the device so the buses are effectively isolated. The control circuitry (DIR,  $\overline{OE}$ ) is powered by  $V_{CCA}$ .

### 8.2 Functional Block Diagram

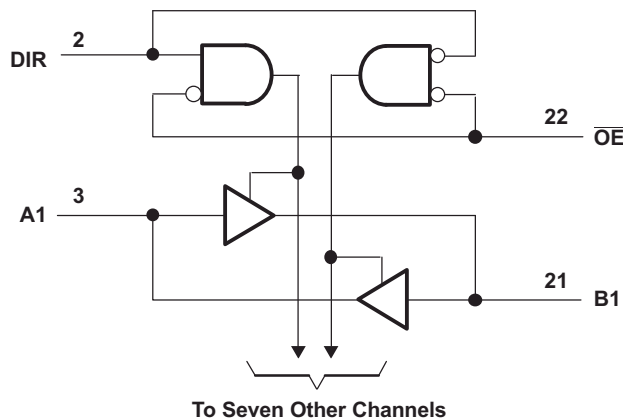

### 8.3 Feature Description

- 24 mA drive at 3-V supply
  - Good for heavier loads and longer traces
- Low  $V_{IH}$ 
  - Allows 3.3-V to 5-V translation

### 8.4 Device Functional Modes

**Table 8-1. Function Table**

INPUTS		OPERATION
$\overline{OE}$	DIR	
L	L	B data to A bus
L	H	A data to B bus
H	X	Isolation

## 9 Application and Implementation

### Note

Information in the following applications sections is not part of the TI component specification, and TI does not warrant its accuracy or completeness. TI's customers are responsible for determining suitability of components for their purposes, as well as validating and testing their design implementation to confirm system functionality.

### 9.1 Application Information

The SN74LVC4245A device pinout allows the designer to switch to a normal all-3.3-V or all-5-V 20-pin '245 device without board re-layout. The designer uses the data paths for pins 2–11 and 14–23 of the SN74LVC4245A to align with the conventional SN74LVC4245 device's pinout. SN74LVC4245A is a high drive CMOS device that can be used for a multitude of bus interface type applications where output drive or PCB trace length is a concern.

### 9.2 Typical Application

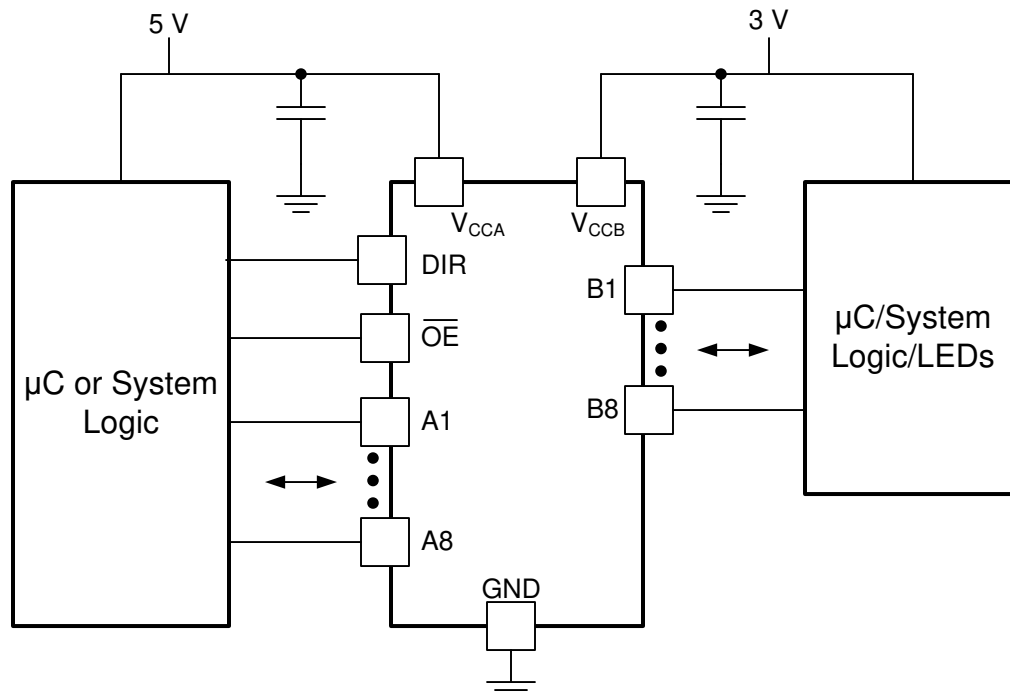

**Figure 9-1. Typical Application Schematic**

#### 9.2.1 Design Requirements

This device uses CMOS technology and has balanced output drive. Care should be taken to avoid bus contention because it can drive currents that would exceed maximum limits. The high drive will also create fast edges into light loads so routing and load conditions should be considered to prevent ringing.

## 9.2.2 Detailed Design Procedure

### 1. Recommended Input Conditions:

- For rise time and fall time specifications, see  $(\Delta t/\Delta V)$  in the [Section 6.4](#) table.
- For specified high and low levels, see  $(V_{IH}$  and  $V_{IL})$  in the [Section 6.4](#) table.

### 2. Recommend Output Conditions:

- Load currents should not exceed  $(I_O \text{ max})$  per output and should not exceed (Continuous current through  $V_{CC}$  or GND) total current for the part. These limits are located in the [Section 6.1](#) table.
- Outputs should not be pulled above  $V_{CC}$ .
- Series resistors on the output may be used if the user desires to slow the output edge signal or limit the output current.

## 9.2.3 Application Curves

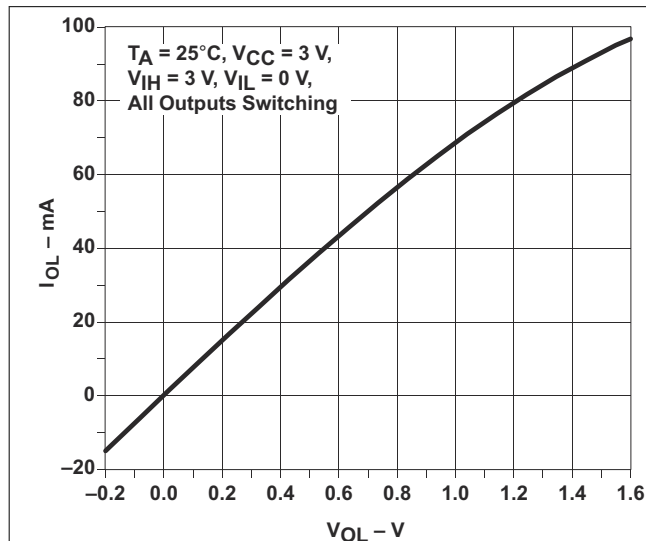

**Figure 9-2. Output Drive Current ( $I_{OL}$ ) vs LOW-level Output Voltage ( $V_{OL}$ )**

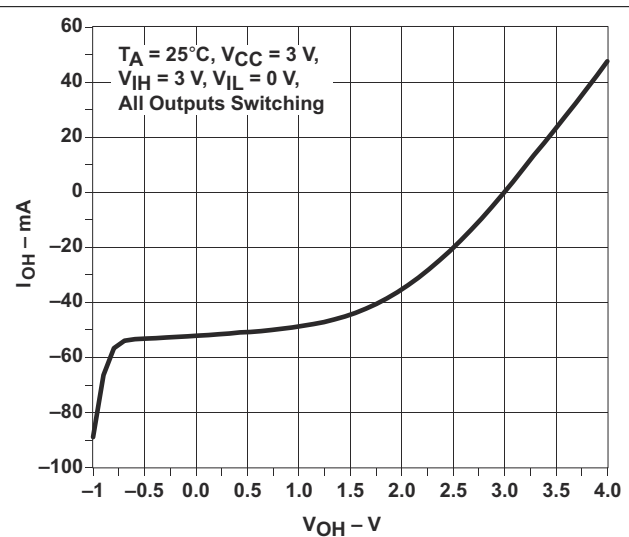

**Figure 9-3. Output Drive Current ( $I_{OH}$ ) vs HIGH-level Output Voltage ( $V_{OH}$ )**

## 10 Power Supply Recommendations

### 10.1 Power-Up Consideration

TI level-translation devices offer an opportunity for successful mixed-voltage signal design. A proper power-up sequence always should be followed to avoid excessive supply current, bus contention, oscillations, or other anomalies caused by improperly biased device terminals. Take these precautions to guard against such power-up problems:

1. Connect ground before any supply voltage is applied.
2. Power up the control side of the device ( $V_{CCA}$  for all four of these devices).
3. Tie  $\overline{OE}$  to  $V_{CCA}$  with a pullup resistor so that it ramps with  $V_{CCA}$ .
4. Depending on the direction of the data path, DIR can be high or low. If DIR high is needed (A data to B bus), ramp it with  $V_{CCA}$ . Otherwise, keep DIR low.

For more information, refer to the [Voltage-Level-Translation Devices](#) application note.

## 11 Layout

### 11.1 Layout Guidelines

When using multiple bit logic devices, inputs should not float. In many cases, functions or parts of functions of digital logic devices are unused. Some examples are when only two inputs of a triple-input AND gate are used, or when only 3 of the 4-buffer gates are used. Such input pins should not be left unconnected because the undefined voltages at the outside connections result in undefined operational states.

Specified in [Figure 11-1](#) are rules that must be observed under all circumstances. All unused inputs of digital logic devices must be connected to a high or low bias to prevent them from floating. The logic level that should be applied to any particular unused input depends on the function of the device. Generally they will be tied to GND or  $V_{CC}$ , whichever makes more sense or is more convenient.

### 11.2 Layout Example

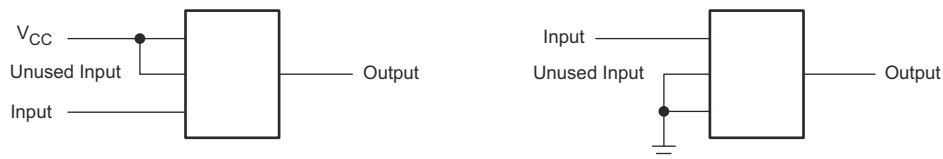

**Figure 11-1. Layout Diagram**

## 12 Device and Documentation Support

### 12.1 Documentation Support

#### 12.1.1 Related Documentation

For related documentation, see the following:

- Texas Instruments, [Voltage-Level-Translation Devices application note](#)

### 12.2 Receiving Notification of Documentation Updates

To receive notification of documentation updates, navigate to the device product folder on [ti.com](#). Click on *Subscribe to updates* to register and receive a weekly digest of any product information that has changed. For change details, review the revision history included in any revised document.

### 12.3 Support Resources

[TI E2E™ support forums](#) are an engineer's go-to source for fast, verified answers and design help — straight from the experts. Search existing answers or ask your own question to get the quick design help you need.

Linked content is provided "AS IS" by the respective contributors. They do not constitute TI specifications and do not necessarily reflect TI's views; see TI's [Terms of Use](#).

### 12.4 Trademarks

TI E2E™ is a trademark of Texas Instruments.

All trademarks are the property of their respective owners.

### 12.5 Electrostatic Discharge Caution



This integrated circuit can be damaged by ESD. Texas Instruments recommends that all integrated circuits be handled with appropriate precautions. Failure to observe proper handling and installation procedures can cause damage.

ESD damage can range from subtle performance degradation to complete device failure. Precision integrated circuits may be more susceptible to damage because very small parametric changes could cause the device not to meet its published specifications.

### 12.6 Glossary

[TI Glossary](#) This glossary lists and explains terms, acronyms, and definitions.

## 13 Mechanical, Packaging, and Orderable Information

The following pages include mechanical, packaging, and orderable information. This information is the most current data available for the designated devices. This data is subject to change without notice and revision of this document. For browser-based versions of this data sheet, refer to the left-hand navigation.

**PACKAGING INFORMATION**

Orderable part number	Status (1)	Material type (2)	Package   Pins	Package qty   Carrier	RoHS (3)	Lead finish/ Ball material (4)	MSL rating/ Peak reflow (5)	Op temp (°C)	Part marking (6)
<a href="#">SN74LVC4245ADBR</a>	Active	Production	SSOP (DB)   24	2000   LARGE T&R	Yes	NIPDAU	Level-1-260C-UNLIM	-40 to 85	LJ245A
SN74LVC4245ADBR.A	Active	Production	SSOP (DB)   24	2000   LARGE T&R	Yes	NIPDAU	Level-1-260C-UNLIM	-40 to 85	LJ245A
SN74LVC4245ADBR.B	Active	Production	SSOP (DB)   24	2000   LARGE T&R	Yes	NIPDAU	Level-1-260C-UNLIM	-40 to 85	LJ245A
SN74LVC4245ADBRE4	Active	Production	SSOP (DB)   24	2000   LARGE T&R	Yes	NIPDAU	Level-1-260C-UNLIM	-40 to 85	LJ245A
<a href="#">SN74LVC4245ADW</a>	Active	Production	SOIC (DW)   24	25   TUBE	Yes	NIPDAU	Level-1-260C-UNLIM	-40 to 85	LVC4245A
SN74LVC4245ADW.B	Active	Production	SOIC (DW)   24	25   TUBE	Yes	NIPDAU	Level-1-260C-UNLIM	-40 to 85	LVC4245A
SN74LVC4245ADWE4	Active	Production	SOIC (DW)   24	25   TUBE	Yes	NIPDAU	Level-1-260C-UNLIM	-40 to 85	LVC4245A
<a href="#">SN74LVC4245ADWG4</a>	Active	Production	SOIC (DW)   24	25   TUBE	Yes	NIPDAU	Level-1-260C-UNLIM	-40 to 85	LVC4245A
SN74LVC4245ADWG4.B	Active	Production	SOIC (DW)   24	25   TUBE	Yes	NIPDAU	Level-1-260C-UNLIM	-40 to 85	LVC4245A
<a href="#">SN74LVC4245ADWR</a>	Active	Production	SOIC (DW)   24	2000   LARGE T&R	Yes	NIPDAU   SN	Level-1-260C-UNLIM	-40 to 85	LVC4245A
SN74LVC4245ADWR.B	Active	Production	SOIC (DW)   24	2000   LARGE T&R	Yes	NIPDAU	Level-1-260C-UNLIM	-40 to 85	LVC4245A
SN74LVC4245ADWRE4	Active	Production	SOIC (DW)   24	2000   LARGE T&R	Yes	NIPDAU	Level-1-260C-UNLIM	-40 to 85	LVC4245A
<a href="#">SN74LVC4245ADWRG4</a>	Active	Production	SOIC (DW)   24	2000   LARGE T&R	Yes	NIPDAU	Level-1-260C-UNLIM	-40 to 85	LVC4245A
SN74LVC4245ADWRG4.B	Active	Production	SOIC (DW)   24	2000   LARGE T&R	Yes	NIPDAU	Level-1-260C-UNLIM	-40 to 85	LVC4245A
<a href="#">SN74LVC4245APW</a>	Active	Production	TSSOP (PW)   24	60   TUBE	Yes	NIPDAU	Level-1-260C-UNLIM	-40 to 85	LJ245A
SN74LVC4245APW.A	Active	Production	TSSOP (PW)   24	60   TUBE	Yes	NIPDAU	Level-1-260C-UNLIM	-40 to 85	LJ245A
SN74LVC4245APW.B	Active	Production	TSSOP (PW)   24	60   TUBE	Yes	NIPDAU	Level-1-260C-UNLIM	-40 to 85	LJ245A
SN74LVC4245APWG4	Active	Production	TSSOP (PW)   24	60   TUBE	Yes	NIPDAU	Level-1-260C-UNLIM	-40 to 85	LJ245A
<a href="#">SN74LVC4245APWR</a>	Active	Production	TSSOP (PW)   24	2000   LARGE T&R	Yes	NIPDAU	Level-1-260C-UNLIM	-40 to 85	LJ245A
SN74LVC4245APWR.A	Active	Production	TSSOP (PW)   24	2000   LARGE T&R	Yes	NIPDAU	Level-1-260C-UNLIM	-40 to 85	LJ245A
SN74LVC4245APWR.B	Active	Production	TSSOP (PW)   24	2000   LARGE T&R	Yes	NIPDAU	Level-1-260C-UNLIM	-40 to 85	LJ245A
SN74LVC4245APWRE4	Active	Production	TSSOP (PW)   24	2000   LARGE T&R	Yes	NIPDAU	Level-1-260C-UNLIM	-40 to 85	LJ245A
SN74LVC4245APWRG4	Active	Production	TSSOP (PW)   24	2000   LARGE T&R	Yes	NIPDAU	Level-1-260C-UNLIM	-40 to 85	LJ245A
<a href="#">SN74LVC4245APWT</a>	Active	Production	TSSOP (PW)   24	250   SMALL T&R	Yes	NIPDAU	Level-1-260C-UNLIM	-40 to 85	LJ245A
SN74LVC4245APWT.B	Active	Production	TSSOP (PW)   24	250   SMALL T&R	Yes	NIPDAU	Level-1-260C-UNLIM	-40 to 85	LJ245A
SN74LVC4245APWTG4	Active	Production	TSSOP (PW)   24	250   SMALL T&R	Yes	NIPDAU	Level-1-260C-UNLIM	-40 to 85	LJ245A

(1) **Status:** For more details on status, see our [product life cycle](#).

(2) **Material type:** When designated, preproduction parts are prototypes/experimental devices, and are not yet approved or released for full production. Testing and final process, including without limitation quality assurance, reliability performance testing, and/or process qualification, may not yet be complete, and this item is subject to further changes or possible discontinuation. If available for ordering, purchases will be subject to an additional waiver at checkout, and are intended for early internal evaluation purposes only. These items are sold without warranties of any kind.

(3) **RoHS values:** Yes, No, RoHS Exempt. See the [TI RoHS Statement](#) for additional information and value definition.

(4) **Lead finish/Ball material:** Parts may have multiple material finish options. Finish options are separated by a vertical ruled line. Lead finish/Ball material values may wrap to two lines if the finish value exceeds the maximum column width.

(5) **MSL rating/Peak reflow:** The moisture sensitivity level ratings and peak solder (reflow) temperatures. In the event that a part has multiple moisture sensitivity ratings, only the lowest level per JEDEC standards is shown. Refer to the shipping label for the actual reflow temperature that will be used to mount the part to the printed circuit board.

(6) **Part marking:** There may be an additional marking, which relates to the logo, the lot trace code information, or the environmental category of the part.

Multiple part markings will be inside parentheses. Only one part marking contained in parentheses and separated by a "~" will appear on a part. If a line is indented then it is a continuation of the previous line and the two combined represent the entire part marking for that device.

**Important Information and Disclaimer:** The information provided on this page represents TI's knowledge and belief as of the date that it is provided. TI bases its knowledge and belief on information provided by third parties, and makes no representation or warranty as to the accuracy of such information. Efforts are underway to better integrate information from third parties. TI has taken and continues to take reasonable steps to provide representative and accurate information but may not have conducted destructive testing or chemical analysis on incoming materials and chemicals. TI and TI suppliers consider certain information to be proprietary, and thus CAS numbers and other limited information may not be available for release.

In no event shall TI's liability arising out of such information exceed the total purchase price of the TI part(s) at issue in this document sold by TI to Customer on an annual basis.

**OTHER QUALIFIED VERSIONS OF SN74LVC4245A :**

- Enhanced Product : [SN74LVC4245A-EP](#)

NOTE: Qualified Version Definitions:

- Enhanced Product - Supports Defense, Aerospace and Medical Applications

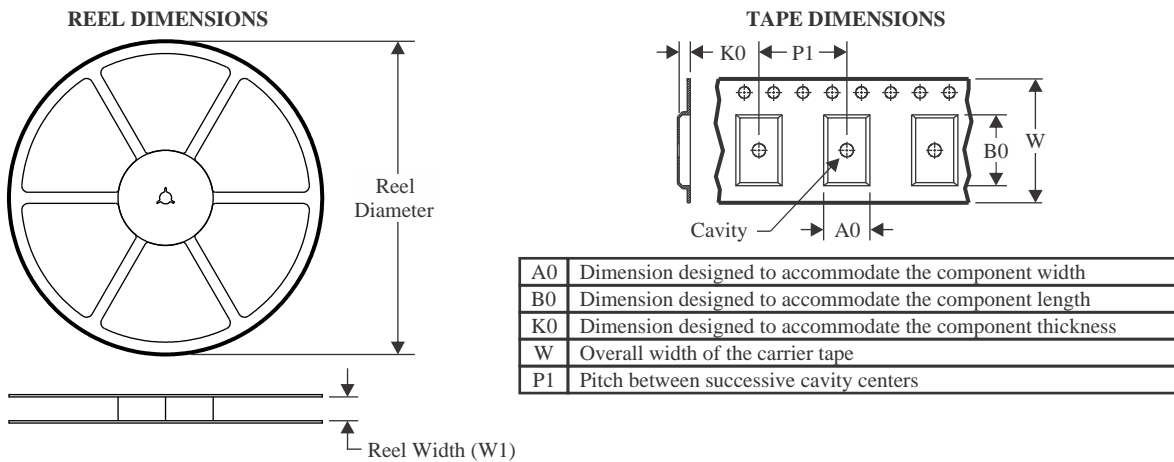
**TAPE AND REEL INFORMATION**

**QUADRANT ASSIGNMENTS FOR PIN 1 ORIENTATION IN TAPE**

\*All dimensions are nominal

Device	Package Type	Package Drawing	Pins	SPQ	Reel Diameter (mm)	Reel Width W1 (mm)	A0 (mm)	B0 (mm)	K0 (mm)	P1 (mm)	W (mm)	Pin1 Quadrant
SN74LVC4245ADBR	SSOP	DB	24	2000	330.0	16.4	8.2	8.8	2.5	12.0	16.0	Q1
SN74LVC4245ADWR	SOIC	DW	24	2000	330.0	24.4	10.75	15.7	2.7	12.0	24.0	Q1
SN74LVC4245ADWRG4	SOIC	DW	24	2000	330.0	24.4	10.75	15.7	2.7	12.0	24.0	Q1
SN74LVC4245APWR	TSSOP	PW	24	2000	330.0	16.4	6.95	8.3	1.6	8.0	16.0	Q1
SN74LVC4245APWT	TSSOP	PW	24	250	330.0	16.4	6.95	8.3	1.6	8.0	16.0	Q1

**TAPE AND REEL BOX DIMENSIONS**

\*All dimensions are nominal

Device	Package Type	Package Drawing	Pins	SPQ	Length (mm)	Width (mm)	Height (mm)
SN74LVC4245ADBR	SSOP	DB	24	2000	353.0	353.0	32.0
SN74LVC4245ADWR	SOIC	DW	24	2000	350.0	350.0	43.0
SN74LVC4245ADWRG4	SOIC	DW	24	2000	350.0	350.0	43.0
SN74LVC4245APWR	TSSOP	PW	24	2000	353.0	353.0	32.0
SN74LVC4245APWT	TSSOP	PW	24	250	353.0	353.0	32.0

**TUBE**

\*All dimensions are nominal

Device	Package Name	Package Type	Pins	SPQ	L (mm)	W (mm)	T (μm)	B (mm)
SN74LVC4245ADW	DW	SOIC	24	25	506.98	12.7	4826	6.6
SN74LVC4245ADW.B	DW	SOIC	24	25	506.98	12.7	4826	6.6
SN74LVC4245ADWE4	DW	SOIC	24	25	506.98	12.7	4826	6.6
SN74LVC4245ADWG4	DW	SOIC	24	25	506.98	12.7	4826	6.6
SN74LVC4245ADWG4.B	DW	SOIC	24	25	506.98	12.7	4826	6.6
SN74LVC4245APW	PW	TSSOP	24	60	530	10.2	3600	3.5
SN74LVC4245APW.A	PW	TSSOP	24	60	530	10.2	3600	3.5
SN74LVC4245APW.B	PW	TSSOP	24	60	530	10.2	3600	3.5
SN74LVC4245APWG4	PW	TSSOP	24	60	530	10.2	3600	3.5

# PW0024A

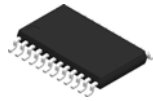

# PACKAGE OUTLINE

## TSSOP - 1.2 mm max height

SMALL OUTLINE PACKAGE

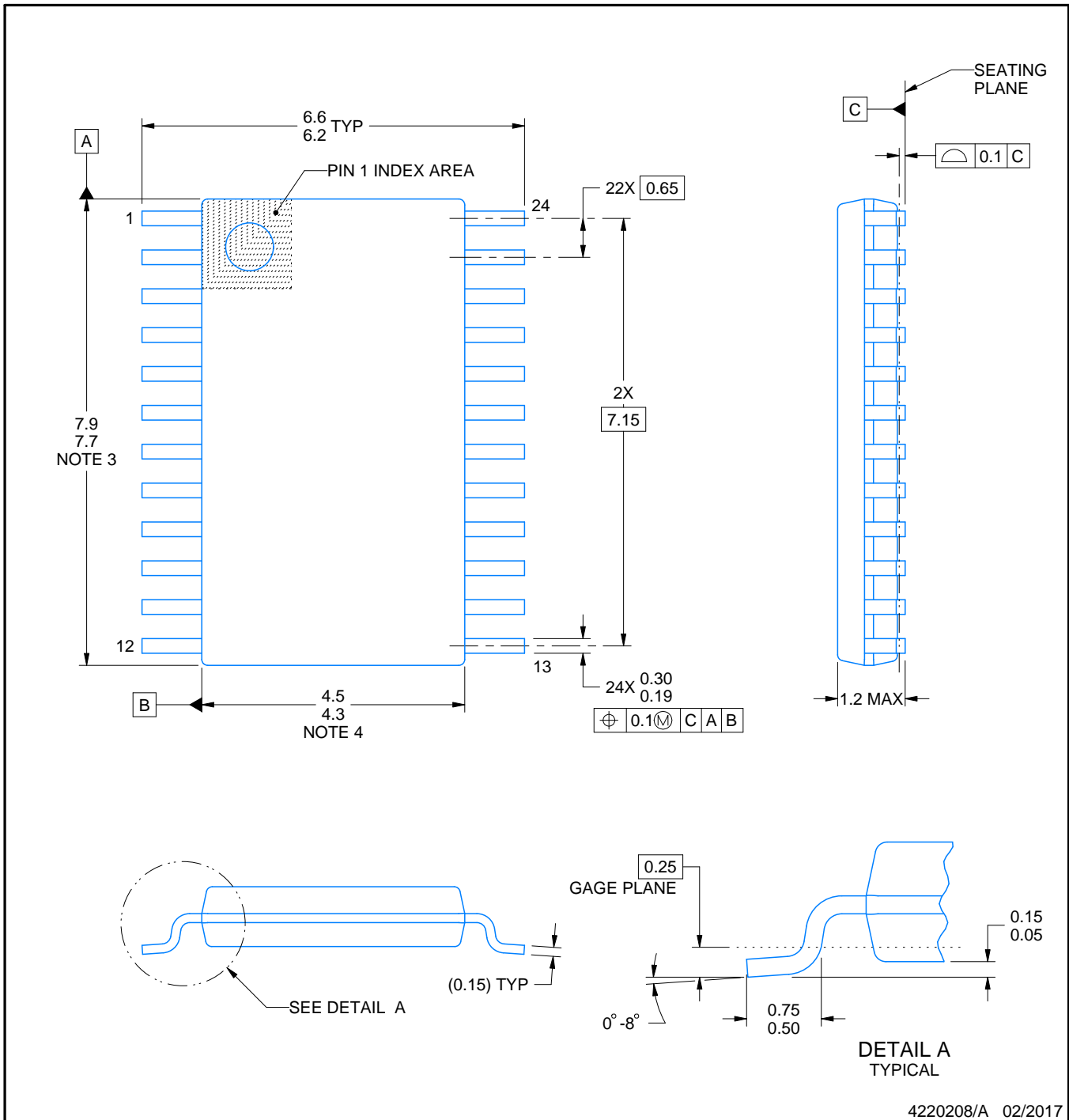

4220208/A 02/2017

### NOTES:

1. All linear dimensions are in millimeters. Any dimensions in parenthesis are for reference only. Dimensioning and tolerancing per ASME Y14.5M.
2. This drawing is subject to change without notice.
3. This dimension does not include mold flash, protrusions, or gate burrs. Mold flash, protrusions, or gate burrs shall not exceed 0.15 mm per side.
4. This dimension does not include interlead flash. Interlead flash shall not exceed 0.25 mm per side.
5. Reference JEDEC registration MO-153.

# EXAMPLE BOARD LAYOUT

PW0024A

TSSOP - 1.2 mm max height

SMALL OUTLINE PACKAGE

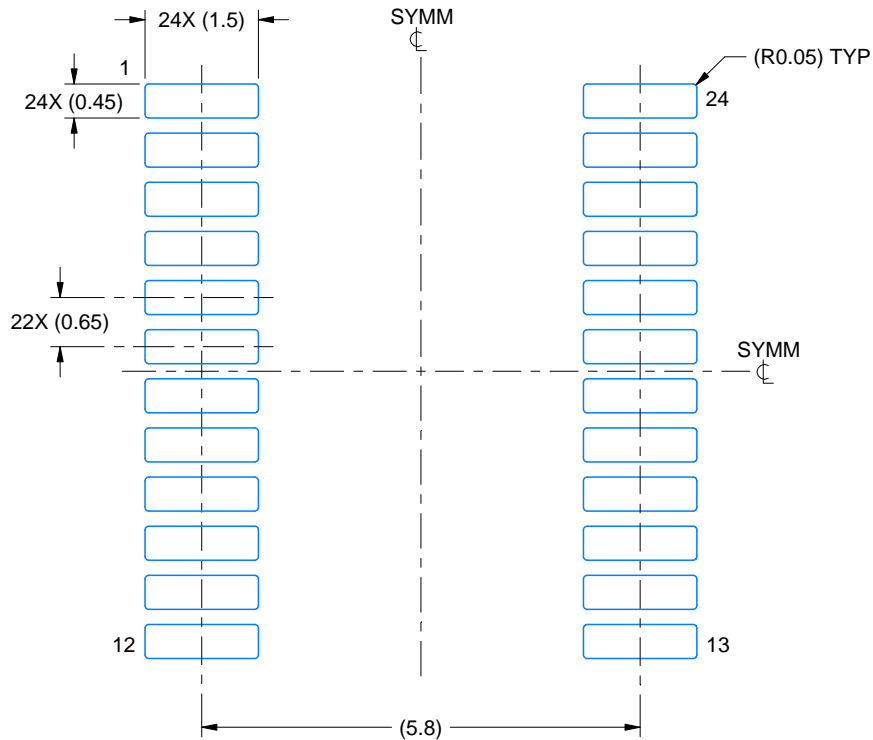

LAND PATTERN EXAMPLE  
EXPOSED METAL SHOWN  
SCALE: 10X

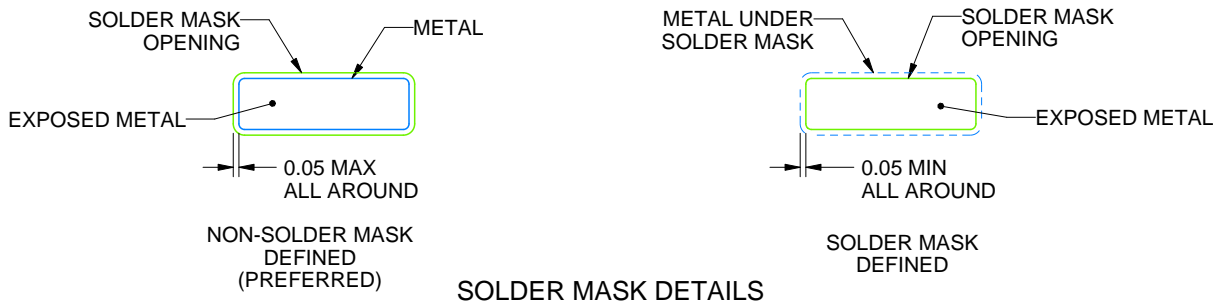

SOLDER MASK DETAILS

4220208/A 02/2017

NOTES: (continued)

- 6. Publication IPC-7351 may have alternate designs.
- 7. Solder mask tolerances between and around signal pads can vary based on board fabrication site.

# EXAMPLE STENCIL DESIGN

PW0024A

TSSOP - 1.2 mm max height

SMALL OUTLINE PACKAGE

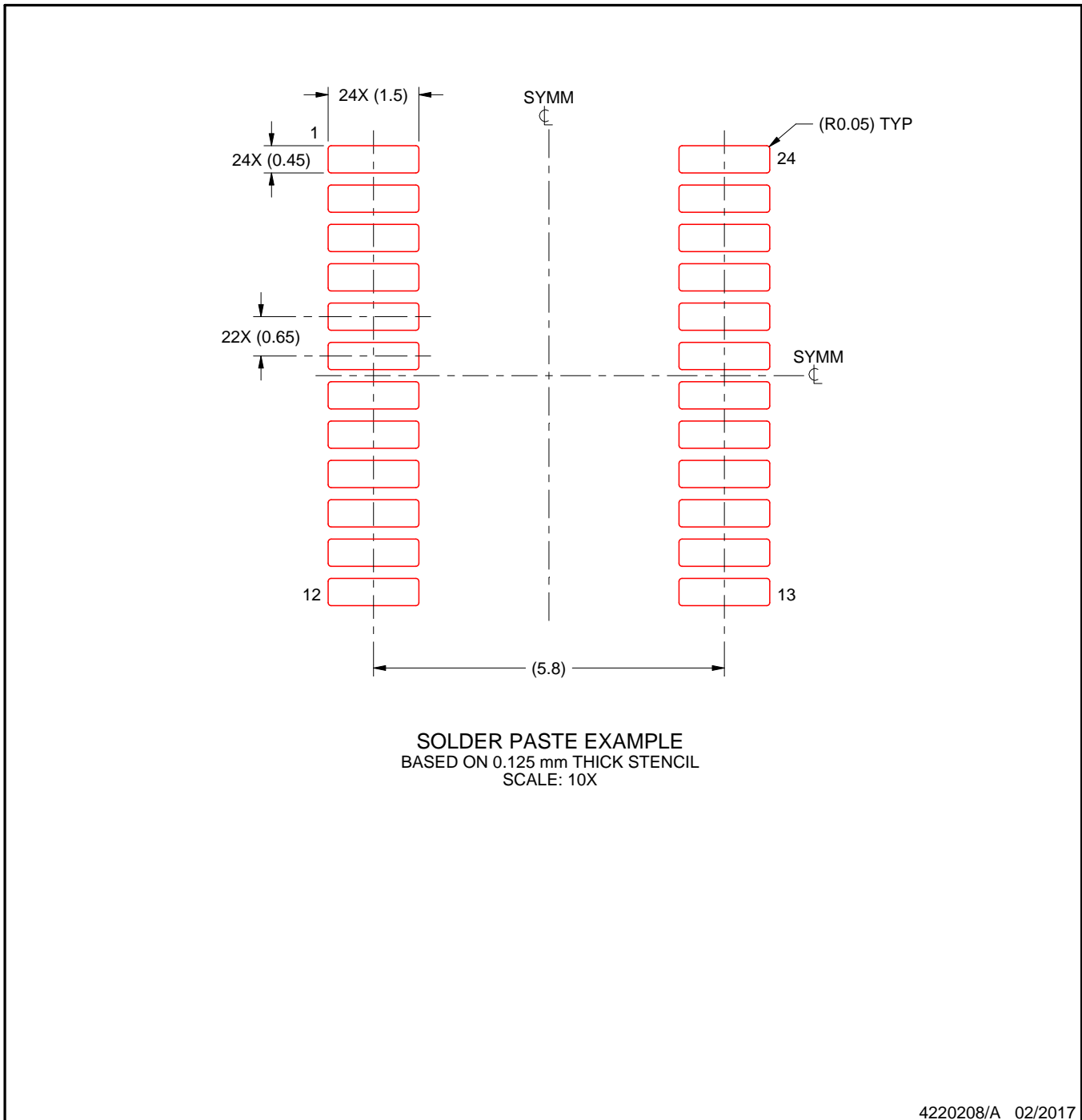

NOTES: (continued)

8. Laser cutting apertures with trapezoidal walls and rounded corners may offer better paste release. IPC-7525 may have alternate design recommendations.
9. Board assembly site may have different recommendations for stencil design.



DW (R-PDSO-G24)

PLASTIC SMALL OUTLINE

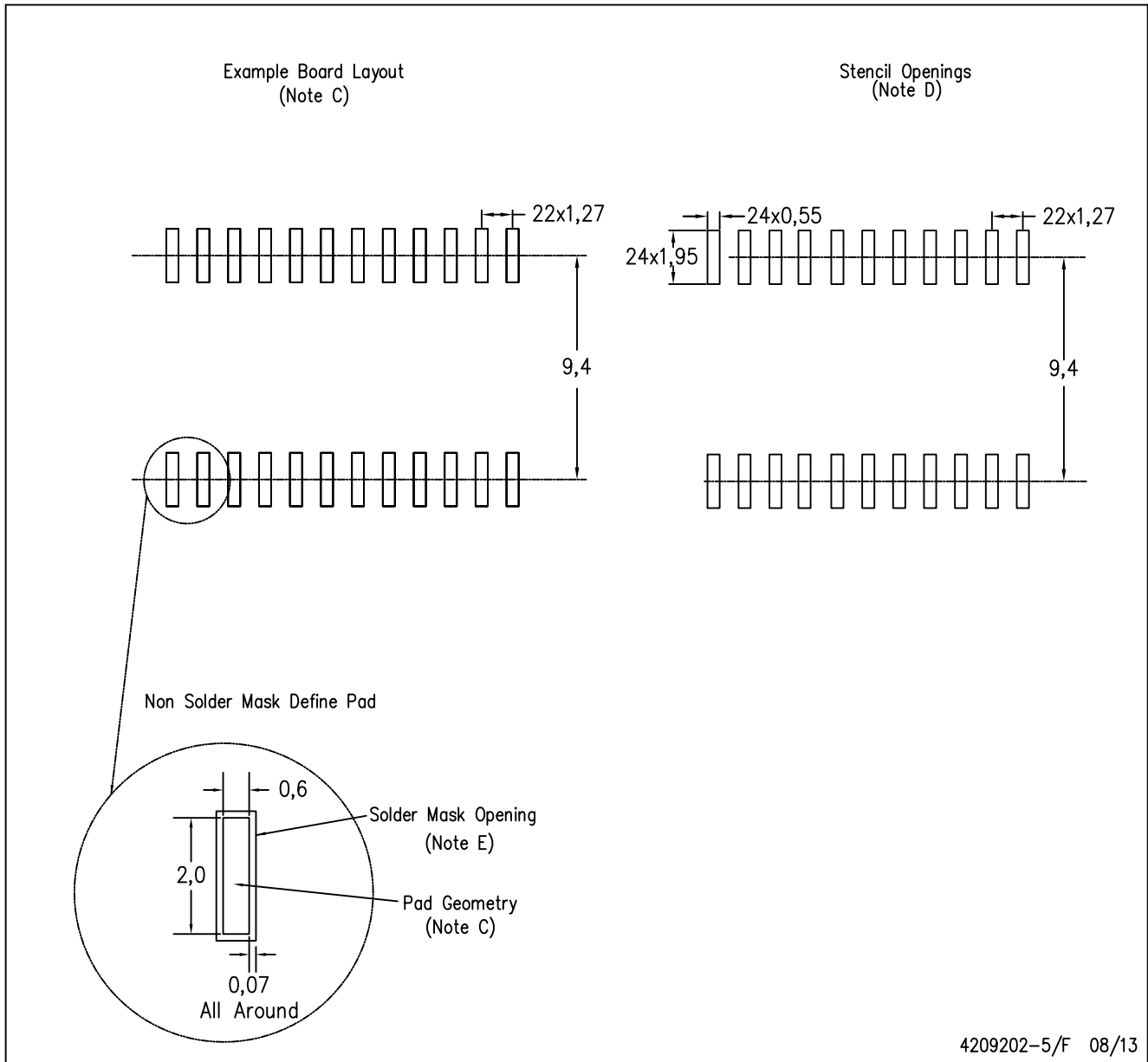

- NOTES:
- All linear dimensions are in millimeters.
  - This drawing is subject to change without notice.
  - Refer to IPC7351 for alternate board design.
  - Laser cutting apertures with trapezoidal walls and also rounding corners will offer better paste release. Customers should contact their board assembly site for stencil design recommendations. Refer to IPC-7525
  - Customers should contact their board fabrication site for solder mask tolerances between and around signal pads.

DB (R-PDSO-G\*\*)

PLASTIC SMALL-OUTLINE

28 PINS SHOWN



- NOTES: A. All linear dimensions are in millimeters.  
 B. This drawing is subject to change without notice.  
 C. Body dimensions do not include mold flash or protrusion not to exceed 0,15.  
 D. Falls within JEDEC MO-150

## IMPORTANT NOTICE AND DISCLAIMER

TI PROVIDES TECHNICAL AND RELIABILITY DATA (INCLUDING DATASHEETS), DESIGN RESOURCES (INCLUDING REFERENCE DESIGNS), APPLICATION OR OTHER DESIGN ADVICE, WEB TOOLS, SAFETY INFORMATION, AND OTHER RESOURCES "AS IS" AND WITH ALL FAULTS, AND DISCLAIMS ALL WARRANTIES, EXPRESS AND IMPLIED, INCLUDING WITHOUT LIMITATION ANY IMPLIED WARRANTIES OF MERCHANTABILITY, FITNESS FOR A PARTICULAR PURPOSE OR NON-INFRINGEMENT OF THIRD PARTY INTELLECTUAL PROPERTY RIGHTS.

These resources are intended for skilled developers designing with TI products. You are solely responsible for (1) selecting the appropriate TI products for your application, (2) designing, validating and testing your application, and (3) ensuring your application meets applicable standards, and any other safety, security, regulatory or other requirements.

These resources are subject to change without notice. TI grants you permission to use these resources only for development of an application that uses the TI products described in the resource. Other reproduction and display of these resources is prohibited. No license is granted to any other TI intellectual property right or to any third party intellectual property right. TI disclaims responsibility for, and you fully indemnify TI and its representatives against any claims, damages, costs, losses, and liabilities arising out of your use of these resources.

TI's products are provided subject to [TI's Terms of Sale](#), [TI's General Quality Guidelines](#), or other applicable terms available either on [ti.com](#) or provided in conjunction with such TI products. TI's provision of these resources does not expand or otherwise alter TI's applicable warranties or warranty disclaimers for TI products. Unless TI explicitly designates a product as custom or customer-specified, TI products are standard, catalog, general purpose devices.

TI objects to and rejects any additional or different terms you may propose.

Copyright © 2025, Texas Instruments Incorporated

Last updated 10/2025