

## HALF-DUPLEX RS-485 TRANSCEIVER

### FEATURES

- Bus-Pin ESD Protection Up to 15 kV
- 1/2 Unit Load—Up to 64 Nodes on a Bus
- Bus-Open-Failsafe Receiver
- Glitch-Free Power-Up/Down Bus Inputs and Outputs
- Available in Small MSOP-8 Package
- Meets or Exceeds the Requirements of the TIA/EIA-485A Standard
- Industry-Standard SN75176 Footprint

### APPLICATIONS

- Motor Control
- Power Inverters
- Industrial Automation
- Building Automation Networks
- Industrial Process Control
- Battery-Powered Applications
- Telecommunications Equipment

### DESCRIPTION

The SN65HVD485E is a half-duplex transceiver designed for RS-485 data bus networks. Powered by a 5V supply, it is fully compliant with the TIA/EIA-485A standard. This device is suitable for data transmission up to 10Mbps over long twisted-pair cables and is designed to operate with very low supply current, typically less than 2mA, exclusive of the load. When in the inactive shutdown mode, the supply current drops below 1mA.

The wide common-mode range and high ESD protection levels of this device make it suitable for demanding applications such as, electrical inverters, status/command signals across telecom racks, cabled chassis interconnects, and industrial automation networks where noise tolerance is essential. The SN65HVD485E matches the industry-standard footprint of the SN75176. Power-on reset circuits keep the outputs in a high-impedance state until the supply voltage has stabilized. A thermal shutdown function protects the device from damage due to system fault conditions. The SN65HVD485E is characterized for operation from  $-40^{\circ}\text{C}$  to  $85^{\circ}\text{C}$  air temperature.

IMPROVED REPLACEMENT FOR:		
PART NUMBER	REPLACE WITH	
ADM485	HVD485E:	Better ESD protection ( $\pm 15$ kV vs unspecified) Faster signaling rate (10 Mbps vs 5 Mbps) More nodes on a bus (64 vs. 32) Wider power supply tolerance (10% vs 5%)
SP485E	HVD485E:	More nodes on a bus (64 vs. 32) Wider power supply tolerance (10% vs. 5%)
LMS485E	HVD485E:	Higher signaling rate (10 Mbps vs 2.5 Mbps) More nodes on a bus (64 vs 32) Wider power supply tolerance (10% vs 5%)
DS485	HVD485E:	Higher signaling rate (10 Mbps vs 2.5 Mbps) Better ESD ( $\pm 15$ kV vs $\pm 2$ kV) More nodes on a bus (64 vs 32) Wider power supply tolerance (10% vs 5%)
LTC485	HVD485E:	Better ESD ( $\pm 15$ kV vs $\pm 2$ kV) Wider power supply tolerance (10% vs 5%)
MAX485E	HVD485E:	Higher signaling rate (10 Mbps vs 2.5 Mbps) More nodes on a bus (64 vs 32) Wider power supply tolerance (10% vs 5%)
ST485E	HVD485E:	Higher signaling rate (10 Mbps vs 5 Mbps) Wider power supply tolerance (10% vs 5%)
ISL8485E	HVD485:	More nodes on a bus (64 vs 32) Faster signaling rate (10 Mbps vs 5 Mbps)



Please be aware that an important notice concerning availability, standard warranty, and use in critical applications of Texas Instruments semiconductor products and disclaimers thereto appears at the end of this data sheet.



These devices have limited built-in ESD protection. The leads should be shorted together or the device placed in conductive foam during storage or handling to prevent electrostatic damage to the MOS gates.

## ORDERING INFORMATION

T <sub>A</sub>	PACKAGE TYPE		
	P	D <sup>(1)</sup>	DGK <sup>(2)</sup>
–40°C to 85°C	SN65HVD485EP Marked as 65HVD485	SN65HVD485ED Marked as VP485	SN65HVD485EDGK Marked as NWJ

(1) The D package is available taped and reeled. Add an R suffix to the device type (i.e., SN65HVD485EDR).

(2) The DGK package is available taped and reeled. Add an R suffix to the device type (i.e., SN65HVD485EDGKR).

## ABSOLUTE MAXIMUM RATINGS

over operating free-air temperature range (unless otherwise noted) <sup>(1)(2)</sup>

	VALUE	UNIT
V <sub>CC</sub> Supply voltage range,	–0.5 to 7	V
Voltage range at A or B	–9 to 14	V
Voltage range at any logic pin	–0.3 to V <sub>CC</sub> + 0.3	V
Receiver output current	–24 to 24	mA
Voltage input range, transient pulse, A and B, through 100Ω (see Figure 13)	–50 V to 50	V
Storage temperature range	–65 to 130	°C
T <sub>J</sub> Junction temperature	170	°C
Continuous total power dissipation	Refer to Package Dissipation Table	

(1) Stresses beyond those listed under *absolute maximum ratings* may cause permanent damage to the device. These are stress ratings only, and functional operation of the device at these or any other conditions beyond those indicated under *recommended operating conditions* is not implied. Exposure to absolute-maximum-rated conditions for extended periods may affect device reliability.

(2) All voltage values, except differential I/O bus voltages, are with respect to network ground terminal.

## PACKAGE DISSIPATION RATINGS

PACKAGE <sup>(1)</sup>	JEDEC BOARD MODEL	T <sub>A</sub> < 25°C POWER RATING	DERATING FACTOR <sup>(2)</sup> ABOVE T <sub>A</sub> = 25°C	T <sub>A</sub> = 70°C POWER RATING	T <sub>A</sub> = 85°C POWER RATING
D	Low k <sup>(3)</sup>	507 mW	4.82 mW/°C	289 mW	217 mW
	High k <sup>(3)</sup>	824 mW	7.85 mW/°C	471 mW	353 mW
P	Low k <sup>(3)</sup>	686 mW	6.53 mW/°C	392 mW	294 mW
	High k <sup>(4)</sup>	583 mW	5.55 mW/°C	333 mW	250 mW

(1) For the most current package and ordering information, see the Package Option Addendum at the end of this document, or see the TI website at [www.ti.com](http://www.ti.com).

(2) This is the inverse of the junction-to-ambient thermal resistance when board-mounted and with no air flow.

(3) In accordance with the low-k thermal metric definitions of EIA/JESD51-3.

(4) In accordance with the high-k thermal metric definitions of EIA/JESDS1-7.

## RECOMMENDED OPERATING CONDITIONS<sup>(1)</sup>

		MIN	TYP	MAX	UNIT
V <sub>CC</sub>	Supply voltage	4.5	5.5		V
V <sub>I</sub>	Input voltage at any bus terminal (separately or common mode)	-7		12	V
V <sub>IH</sub>	High-level input voltage (D, DE, or RE inputs)	2	V <sub>CC</sub>		V
V <sub>IL</sub>	Low-level input voltage (D, DE, or RE inputs)	0	0.8		V
V <sub>ID</sub>	Differential input voltage	-12		12	V
I <sub>O</sub>	Output current	Driver		60	mA
		Receiver	-8	8	
R <sub>L</sub>	Differential load resistance	54	60		Ω
1/t <sub>UI</sub>	Signaling rate	0		10	Mbps
T <sub>A</sub>	Operating free-air temperature	-40		85	°C
T <sub>J</sub>	Junction temperature <sup>(2)</sup>	-40		130	°C

- (1) The algebraic convention, in which the least positive (most negative) limit is designated as minimum, is used in this data sheet.  
 (2) See thermal characteristics table for information on maintenance of this specification for the DGK package.

## SUPPLY CURRENT

over recommended operating conditions (unless otherwise noted)

PARAMETER		TEST CONDITIONS		MIN	TYP <sup>(1)</sup>	MAX	UNIT
I <sub>CC</sub>	Driver and receiver enabled	D at V <sub>CC</sub> or open or 0V,	DE at V <sub>CC</sub> , RE at 0V, No load			2	mA
	Driver and receiver disabled	D at V <sub>CC</sub> or open,	DE at 0V, RE at V <sub>CC</sub>			1	mA

- (1) All typical values are at 25°C and with a 5-V supply.

## ELECTROSTATIC DISCHARGE PROTECTION

PARAMETER	TEST CONDITIONS	MIN	TYP <sup>(1)</sup>	MAX	UNIT
Human body model	Bus terminals and GND		±15		kV
Human body model <sup>(2)</sup>	All pins		±4		kV
Charged-device-model <sup>(3)</sup>	All pins		±1		kV

- (1) All typical values at 25°C  
 (2) Tested in accordance with JEDEC Standard 22, Test Method A114-A.  
 (3) Tested in accordance with JEDEC Standard 22, Test Method C101.

## DRIVER ELECTRICAL CHARACTERISTICS

over recommended operating conditions (unless otherwise noted)

PARAMETER		TEST CONDITIONS	MIN	TYP <sup>(1)</sup>	MAX	UNIT
V <sub>OD</sub>	Differential output voltage	I <sub>O</sub> = 0, No load	3	4.3		V
		R <sub>L</sub> = 54 Ω, See <a href="#">Figure 1</a>	1.5	2.3		
		V <sub>TEST</sub> = -7 V to 12 V, See <a href="#">Figure 2</a>	1.5			
Δ V <sub>OD</sub>	Change in magnitude of differential output voltage	See <a href="#">Figure 1</a> and <a href="#">Figure 2</a>	-0.2	0	0.2	V
V <sub>OC(SS)</sub>	Steady-state common-mode output voltage	See <a href="#">Figure 3</a>	1	2.6	3	V
ΔV <sub>OC(SS)</sub>	Change in steady-state common-mode output voltage		-0.1	0	0.1	V
V <sub>OC(PP)</sub>	Common-mode output voltage	See <a href="#">Figure 3</a>		500		mV
I <sub>OZ</sub>	High-impedance output current	See receiver input currents				μA
I <sub>I</sub>	Input current	D, DE	-100		100	μA
I <sub>OS</sub>	Short-circuit output current	-7 V ≤ V <sub>O</sub> ≤ 12 V, See <a href="#">Figure 7</a>	-250		250	mA

(1) All typical values are at 25°C and with a 5-V supply.

## DRIVER SWITCHING CHARACTERISTICS

over recommended operating conditions (unless otherwise noted)

PARAMETER		TEST CONDITIONS	MIN	TYP	MAX	UNIT
t <sub>PLH</sub>	Propagation delay time, low-to-high-level output	R <sub>L</sub> = 54 Ω, C <sub>L</sub> = 50 pF, See <a href="#">Figure 4</a>			30	ns
t <sub>PHL</sub>	Propagation delay time, high-to-low-level output				30	
t <sub>r</sub>	Differential output signal rise time				25	
t <sub>f</sub>	Differential output signal fall time				25	
t <sub>sk(p)</sub>	Pulse skew (  t <sub>PHL</sub> - t <sub>PLH</sub>   )				5	
t <sub>PZH</sub>	Propagation delay time, high-impedance-to-high-level output	R <sub>L</sub> = 110 Ω, $\overline{RE}$ at 0 V, See <a href="#">Figure 5</a>			150	ns
t <sub>PHZ</sub>	Propagation delay time, high-level-to-high-impedance output				100	
t <sub>PZL</sub>	Propagation delay time, high-impedance-to-low-level output	R <sub>L</sub> = 110 Ω, $\overline{RE}$ at 0 V See <a href="#">Figure 6</a>			150	ns
t <sub>PLZ</sub>	Propagation delay time, low-level-to-high-impedance output				100	
t <sub>PZH(SHN)</sub>	Propagation delay time, shutdown-to-high-level output	R <sub>L</sub> = 110 Ω, $\overline{RE}$ at VCC, See <a href="#">Figure 5</a>			2600	ns
t <sub>PZL(SHDN)</sub>	Propagation delay time, shutdown-to-low-level output	R <sub>L</sub> = 110 Ω, $\overline{RE}$ at VCC, See <a href="#">Figure 6</a>			2600	ns

## RECEIVER ELECTRICAL CHARACTERISTICS

over recommended operating conditions (unless otherwise noted)

PARAMETER		TEST CONDITIONS	MIN	TYP <sup>(1)</sup>	MAX	UNIT
V <sub>IT+</sub>	Positive-going input threshold voltage	I <sub>O</sub> = -8 mA		-85	-10	mV
V <sub>IT-</sub>	Negative-going input threshold voltage	I <sub>O</sub> = 8 mA	-200	-115		mV
V <sub>hys</sub>	Hysteresis voltage (V <sub>IT+</sub> - V <sub>IT-</sub> )			30		mV
V <sub>OH</sub>	High-level output voltage	V <sub>ID</sub> = 200 mV, I <sub>OH</sub> = -8 mA, See <a href="#">Figure 8</a>	4	4.6		V
V <sub>OL</sub>	Low-level output voltage	V <sub>ID</sub> = -200 mV, I <sub>OH</sub> = 8 mA, See <a href="#">Figure 8</a>		0.15	0.4	V
I <sub>OZ</sub>	High-impedance-state output current	V <sub>O</sub> = 0 to V <sub>CC</sub> , $\overline{RE} = V_{CC}$	-1		1	μA
I <sub>I</sub>	Bus input current	V <sub>IH</sub> = 12 V, V <sub>CC</sub> = 5 V			0.5	mA
		V <sub>IH</sub> = 12 V, V <sub>CC</sub> = 0			0.5	
		V <sub>IH</sub> = -7 V, V <sub>CC</sub> = 5 V	-0.4			
		V <sub>IH</sub> = -7 V, V <sub>CC</sub> = 0	-0.4			
I <sub>IH</sub>	High-level input current ( $\overline{RE}$ )	V <sub>IH</sub> = 2 V	-60	-30		μA
I <sub>IL</sub>	Low-level input current ( $\overline{RE}$ )	V <sub>IL</sub> = 0.8 V	-60	-30		μA
C <sub>diff</sub>	Differential input capacitance	V <sub>I</sub> = 0.4 sin(4E6πt) + 0.5 V, DE at 0 V		7		pF

(1) All typical values are at 25°C and with a 5-V supply.

## RECEIVER SWITCHING CHARACTERISTICS

over recommended operating conditions (unless otherwise noted)

PARAMETER		TEST CONDITIONS	MIN	TYP	MAX	UNIT
t <sub>PLH</sub>	Propagation delay time, low-to-high-level output	V <sub>ID</sub> = -1.5 V to 1.5 V, C <sub>L</sub> = 15 pF, See <a href="#">Figure 9</a>			200	ns
t <sub>PHL</sub>	Propagation delay time, high-to-low-level output				200	
t <sub>sk(p)</sub>	Pulse skew ( t <sub>PHL</sub> - t <sub>PLH</sub>  )			6		
t <sub>r</sub>	Output signal rise time	C <sub>L</sub> = 15 pF, DE at 3 V, See <a href="#">Figure 10</a> and <a href="#">Figure 11</a>			3	ns
t <sub>f</sub>	Output signal fall time				3	
t <sub>PZH</sub>	Output enable time to high level	C <sub>L</sub> = 15 pF, DE at 0 V, See <a href="#">Figure 12</a>			50	ns
t <sub>PZL</sub>	Output enable time to low level				50	
t <sub>PHZ</sub>	Output enable time from high level				50	
t <sub>PLZ</sub>	Output enable time from low level				50	
t <sub>PZH(SHDN)</sub>	Propagation delay time, shutdown-to-high-level output	C <sub>L</sub> = 15 pF, DE at 0 V, See <a href="#">Figure 12</a>			3500	ns
t <sub>PZL(SHDN)</sub>	Propagation delay time, shutdown-to-low-level output				3500	

PARAMETER MEASUREMENT INFORMATION

NOTE:

Test load capacitance includes probe and jig capacitance (unless otherwise specified). Signal generator characteristics: rise and fall time <6 ns, pulse rate 100kHz, 50% duty cycle.  $Z_O = 50\Omega$  (unless otherwise specified).

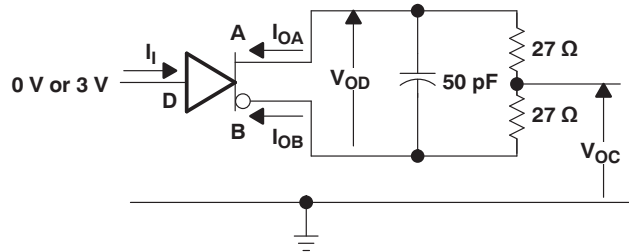

Figure 1. Driver Test Circuit,  $V_{OD}$  and  $V_{OC}$  Without Common-Mode Loading

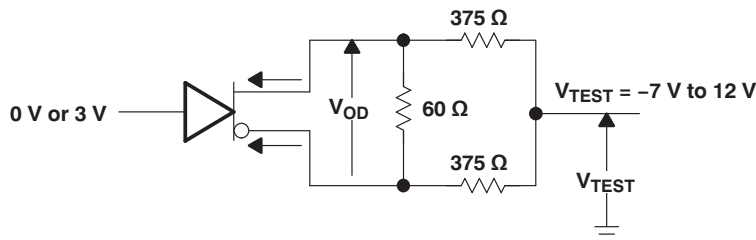

Figure 2. Driver Test Circuit,  $V_{OD}$  With Common-Mode Loading

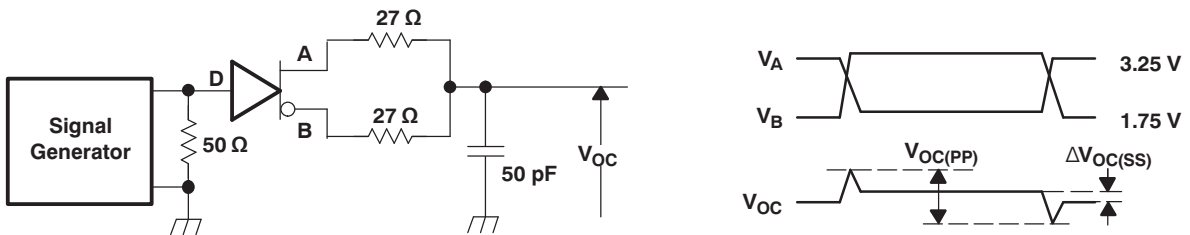

Figure 3. Driver  $V_{OC}$  Test Circuit and Waveforms

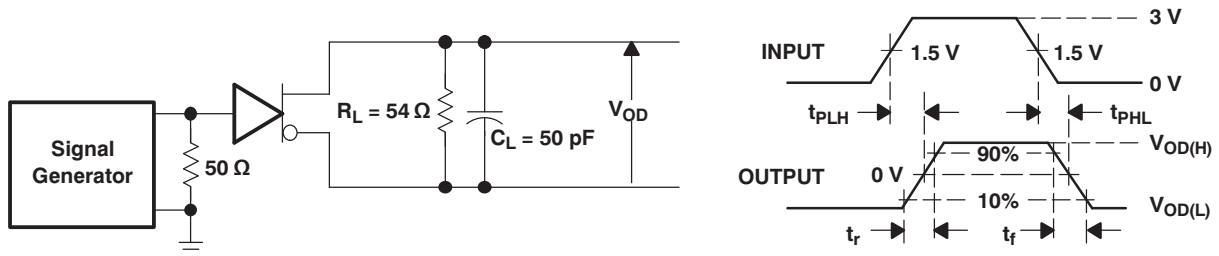

Figure 4. Driver Switching Test Circuit and Waveforms

PARAMETER MEASUREMENT INFORMATION (continued)

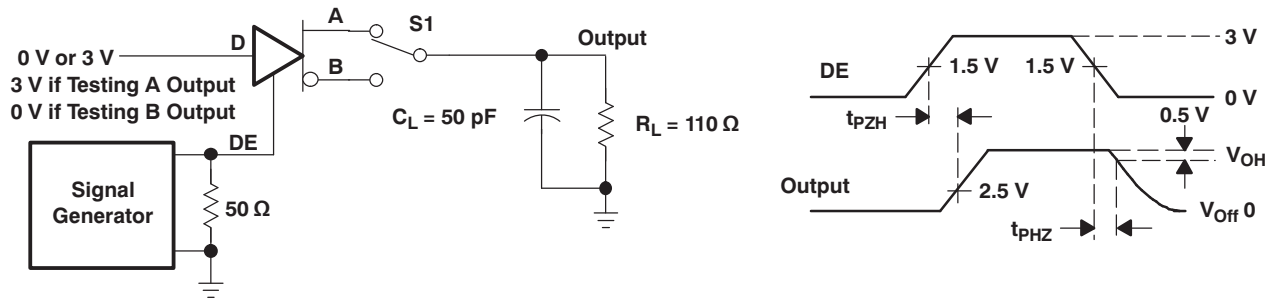

Figure 5. Driver Enable/Disable Test Circuit and Waveforms, High Output

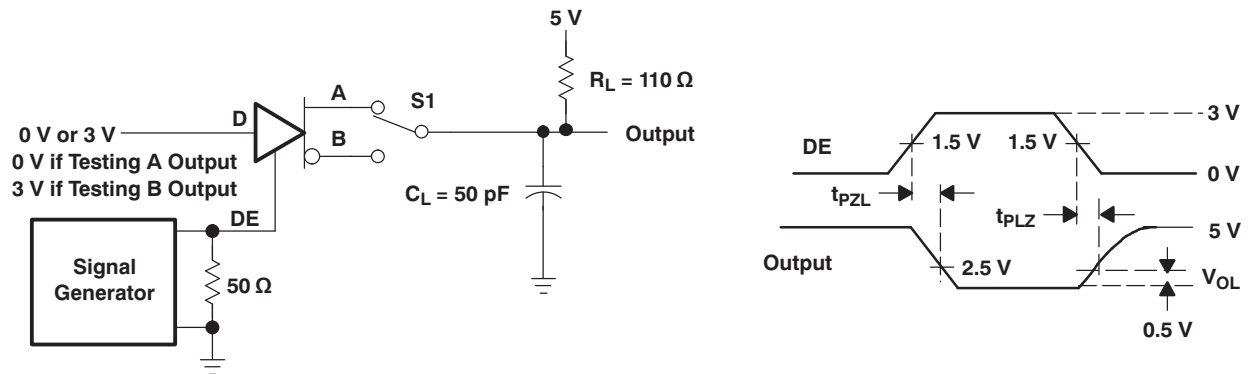

Figure 6. Driver Enable/Disable Test Circuit and Waveforms, Low Output

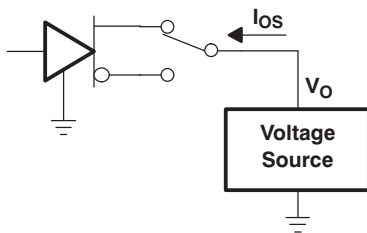

Figure 7. Driver Short-Circuit Test

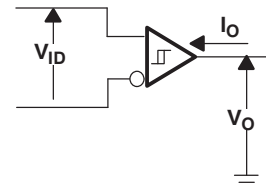

Figure 8. Receiver Parameter Definitions

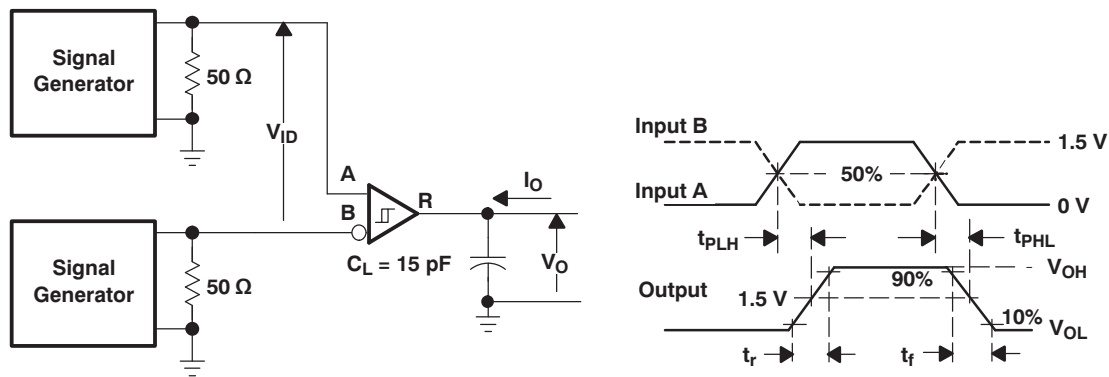

Figure 9. Receiver Switching Test Circuit and Waveforms

PARAMETER MEASUREMENT INFORMATION (continued)

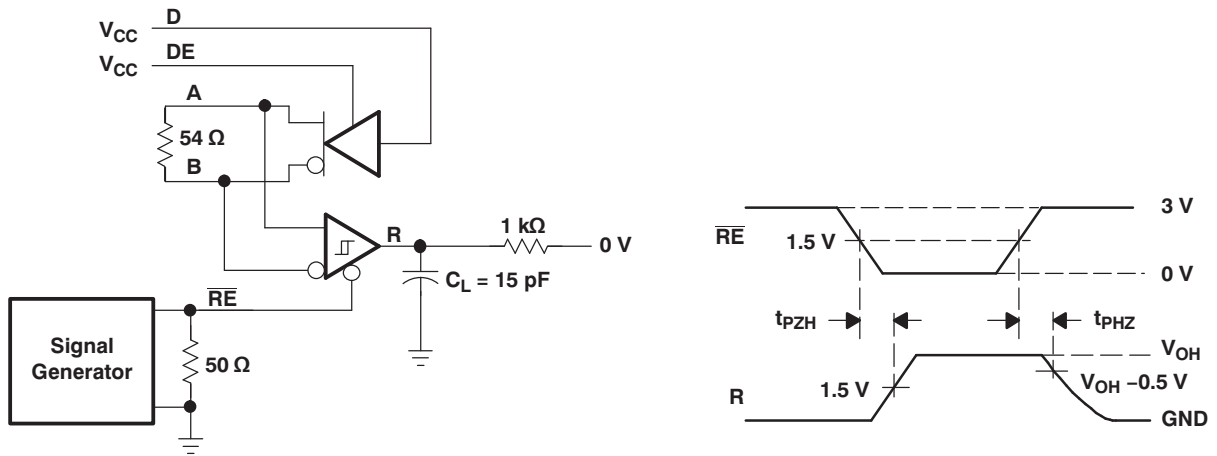

Figure 10. Receiver Enable/Disable Test Circuit and Waveforms, Data Output High

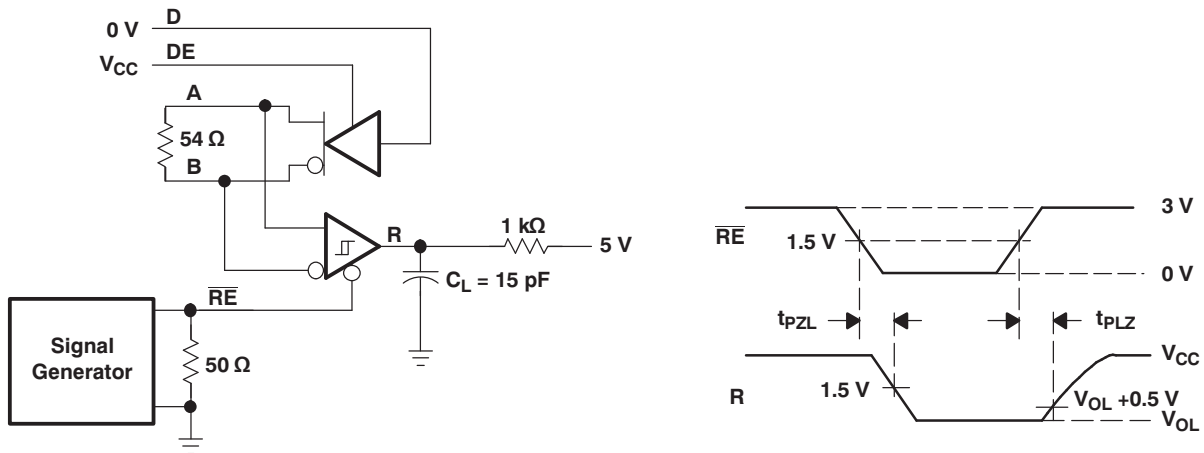

Figure 11. Receiver Enable/Disable Test Circuit and Waveforms, Data Output Low

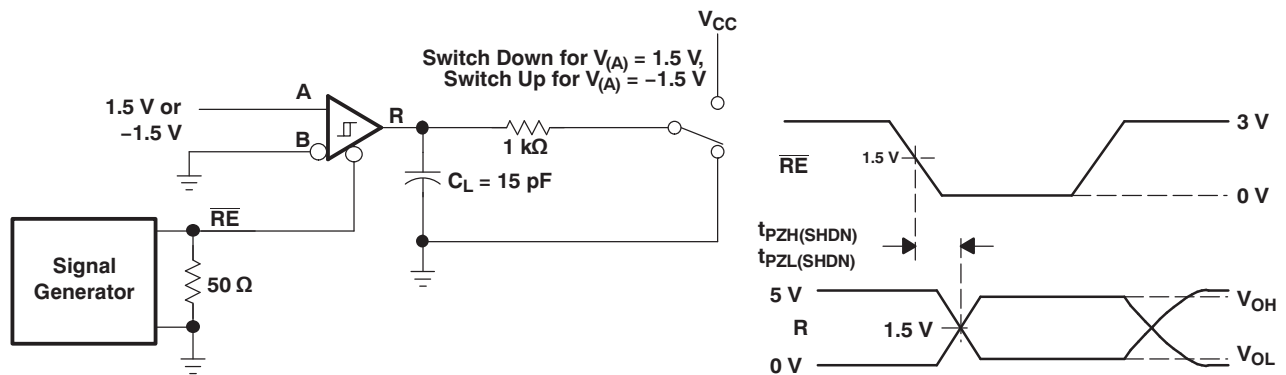

Figure 12. Receiver Enable From Shutdown Test Circuit and Waveforms

PARAMETER MEASUREMENT INFORMATION (continued)

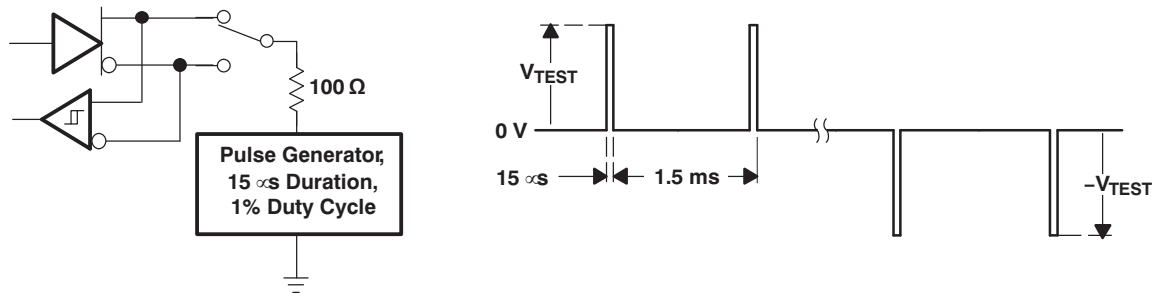
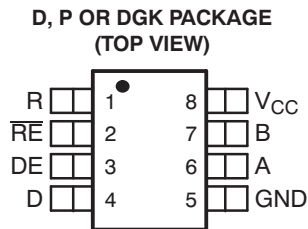

Figure 13. Test Circuit and Waveforms, Transient Over-Voltage Test

DEVICE INFORMATION

PIN ASSIGNMENTS



LOGIC DIAGRAM (POSITIVE LOGIC)

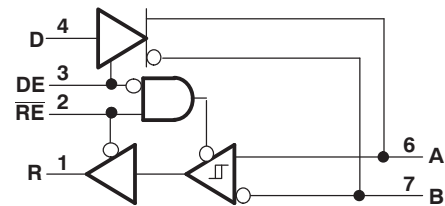

FUNCTION TABLE<sup>(1)</sup>

DRIVER				RECEIVER		
INPUT D	ENABLE DE	OUTPUTS		DIFFERENTIAL INPUTS V <sub>ID</sub> = V <sub>A</sub> - V <sub>B</sub>	ENABLE RE	OUTPUT R
		A	B			
H	H	H	L	V <sub>ID</sub> ≤ -0.2 V	L	L
L	H	L	H	-0.2 V < V <sub>ID</sub> < -0.01 V	L	?
X	L	Z	Z	-0.01 V ≤ V <sub>ID</sub>	L	H
Open	H	H	L	X	H	Z
X	Open	Z	Z	Open circuit	L	H
				X	Open	Z

(1) H= high level; L = low level; Z = high impedance; X = irrelevant; ? = indeterminate

EQUIVALENT INPUT AND OUTPUT SCHEMATIC DIAGRAMS

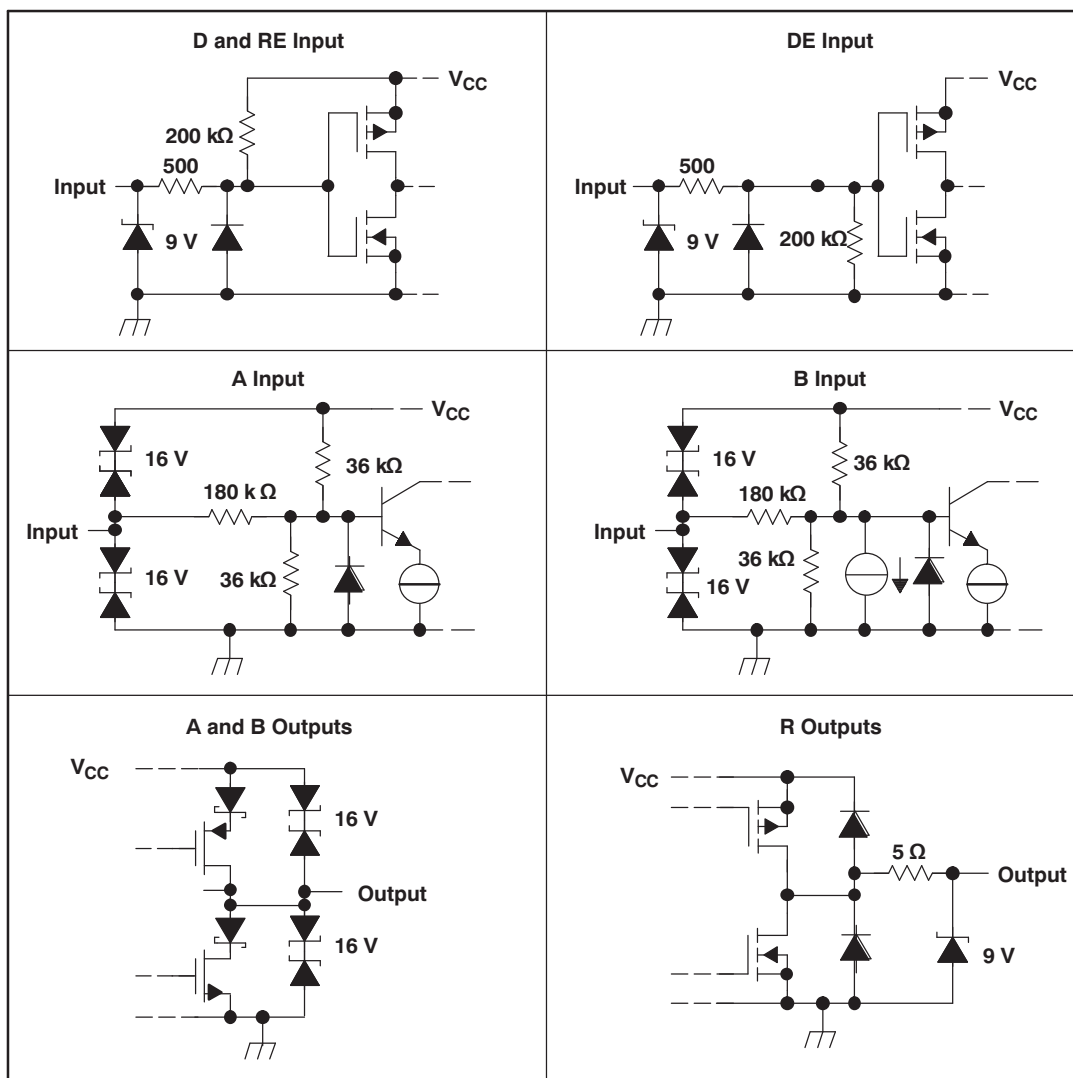

THERMAL CHARACTERISTICS

DGK PACKAGE			MIN	TYP	MAX	UNIT
$\theta_{JA}$	Junction-to-ambient thermal resistance <sup>(1)</sup>	Low-k <sup>(2)</sup> board, no air flow		266		°C/W
		High-k <sup>(3)</sup> board, no air flow		180		
$\theta_{JB}$	Junction-to-board thermal resistance	High-k <sup>(3)</sup> board, no air flow		108		°C/W
$\theta_{JC}$	Junction-to-case thermal resistance			66		
$P_{(AVG)}$	Average power dissipation	$R_L = 54\Omega$ , Input to D is a 10 Mbps 50% duty cycle square wave $V_{CC}$ at 5.5 V, $T_J = 130^\circ\text{C}$			219	mW
$T_A$	Ambient air temperature	JEDEC High K board model	-40		93	°C
		JEDEC Low K board model	-40		75	°C
$T_{SD}$	Thermal shut-down junction temperature			165		°C

(1) See TI application note [SZZA003](#), Package Thermal Characterization Methodologies, for an explanation of this parameter.  
 (2) JESD51-3 Low Effective Thermal Conductivity Test Board for Leaded Surface Mount Packages  
 (3) JESD51-7 High Effective Thermal Conductivity Test Board for Leaded Surface Mount Packages

**TYPICAL CHARACTERISTICS**

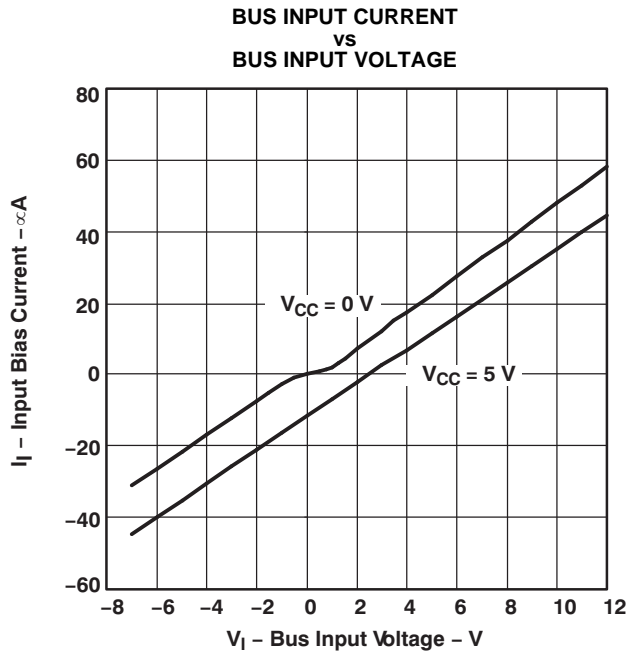

Figure 14.

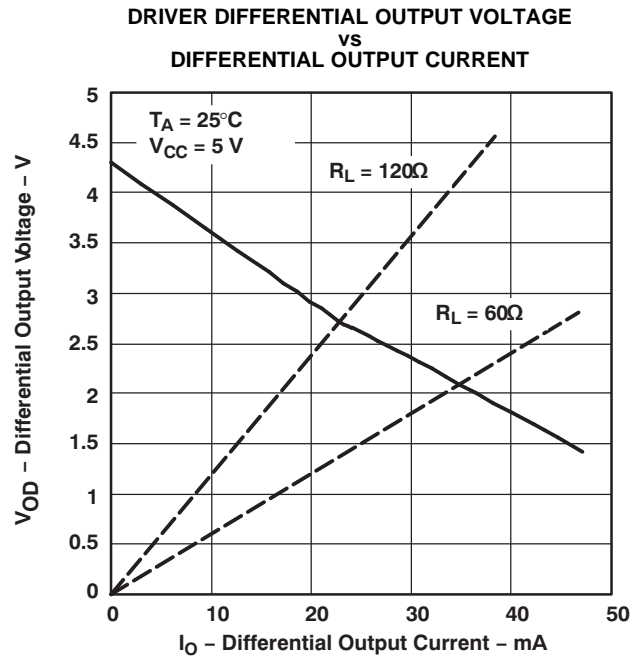
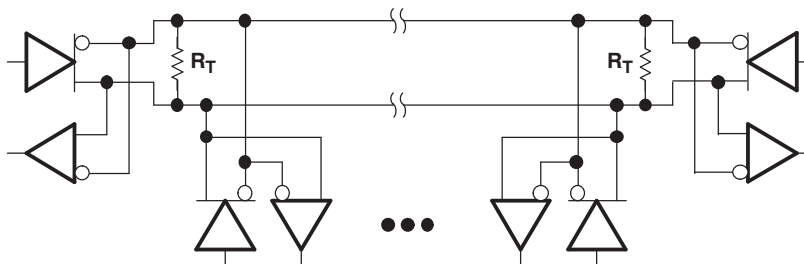

Figure 15.

## APPLICATION INFORMATION



NOTE: The line should be terminated at both ends with its characteristic impedance ( $R_T = Z_0$ ). Stub lengths off the main line should be kept as short as possible.

**Figure 16. Typical Application Circuit**

### POWER USAGE IN AN RS-485 TRANSCEIVER

Power consumption is a concern in many applications. Power supply current is delivered to the bus load as well as to the transceiver circuitry. For a typical RS-485 bus configuration, the load that an active driver must drive consists of all of the receiving nodes, plus the termination resistors at each end of the bus.

The load presented by the receiving nodes depends on the input impedance of the receiver. The TIA/EIA-485-A standard defines a unit load as allowing up to 1mA. With up to 32 unit loads allowed on the bus, the total current supplied to all receivers can be as high as 32mA. The HVD485E is rated as a 1/2 unit load device, so up to 64 can be connected on a bus.

The current in the termination resistors depends on the differential bus voltage. The standard requires active drivers to produce at least 1.5V of differential signal. For a bus terminated with one standard 120- $\Omega$  resistor at each end, this sums to 25 mA differential output current whenever the bus is active. Typically the HVD485E can drive more than 25mA to a 60 $\Omega$  load, resulting in a differential output voltage higher than the minimum required by the standard. (See [Figure 15](#).)

Supply current increases with signaling rate primarily due to the totum pole outputs of the driver. When these outputs change state, there is a moment when both the high-side and low-side output transistors are conducting and this creates a short spike in the supply current. As the frequency of state changes increases, more power is used.

**APPLICATION INFORMATION (continued)**

**THERMAL CHARACTERISTICS OF IC PACKAGES**

$\theta_{JA}$  (Junction-to-Ambient Thermal Resistance) is defined as the difference in junction temperature to ambient temperature divided by the operating power

$\theta_{JA}$  is NOT a constant and is a strong function of

- the PCB design (50% variation)
- altitude (20% variation)
- device power (5% variation)

$\theta_{JA}$  can be used to compare the thermal performance of packages if the specific test conditions are defined and used. Standardized testing includes specification of PCB construction, test chamber volume, sensor locations, and the thermal characteristics of holding fixtures.  $\theta_{JA}$  is often misused when it is used to calculate junction temperatures for other installations.

TI uses two test PCBs as defined by JEDEC specifications. The low-k board gives average in-use condition thermal performance and consists of a single trace layer 25 mm long and 2-oz thick copper. The high-k board gives best case in-use condition and consists of two 1-oz buried power planes with a single trace layer 25 mm long with 2-oz thick copper. A 4% to 50% difference in  $\theta_{JA}$  can be measured between these two test cards

$\theta_{JC}$  (Junction-to-Case Thermal Resistance) is defined as difference in junction temperature to case divided by the operating power. It is measured by putting the mounted package up against a copper block cold plate to force heat to flow from die, through the mold compound into the copper block.

$\theta_{JC}$  is a useful thermal characteristic when a heatsink is applied to package. It is NOT a useful characteristic to predict junction temperature as it provides pessimistic numbers if the case temperature is measured in a non-standard system and junction temperatures are backed out. It can be used with  $\theta_{JB}$  in 1-dimensional thermal simulation of a package system.

$\theta_{JB}$  (Junction-to-Board Thermal Resistance) is defined to be the difference in the junction temperature and the PCB temperature at the center of the package (closest to the die) when the PCB is clamped in a cold-plate structure.  $\theta_{JB}$  is only defined for the high-k test card.

$\theta_{JB}$  provides an overall thermal resistance between the die and the PCB. It includes a bit of the PCB thermal resistance (especially for BGA's with thermal balls) and can be used for simple 1-dimensional network analysis of package system (see [Figure 17](#)).

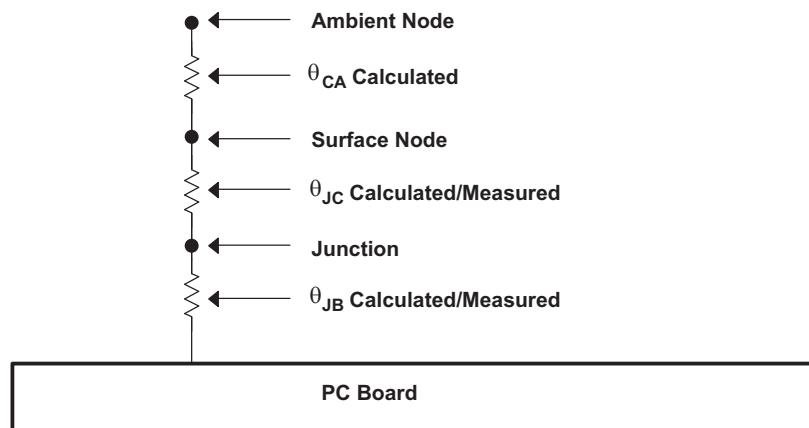

**Figure 17. Thermal Resistance**

**PACKAGING INFORMATION**

Orderable Device	Status <sup>(1)</sup>	Package Type	Package Drawing	Pins	Package Qty	Eco Plan <sup>(2)</sup>	Lead/ Ball Finish	MSL Peak Temp <sup>(3)</sup>	Samples (Requires Login)
SN65HVD485ED	ACTIVE	SOIC	D	8	75	Green (RoHS & no Sb/Br)	CU NIPDAU	Level-1-260C-UNLIM	
SN65HVD485EDG4	ACTIVE	SOIC	D	8	75	Green (RoHS & no Sb/Br)	CU NIPDAU	Level-1-260C-UNLIM	
SN65HVD485EDGK	ACTIVE	VSSOP	DGK	8	80	Green (RoHS & no Sb/Br)	CU NIPDAU	Level-1-260C-UNLIM	
SN65HVD485EDGKG4	ACTIVE	VSSOP	DGK	8	80	Green (RoHS & no Sb/Br)	CU NIPDAU	Level-1-260C-UNLIM	
SN65HVD485EDGKR	ACTIVE	VSSOP	DGK	8	2500	Green (RoHS & no Sb/Br)	CU NIPDAU	Level-1-260C-UNLIM	
SN65HVD485EDGKRG4	ACTIVE	VSSOP	DGK	8	2500	Green (RoHS & no Sb/Br)	CU NIPDAU	Level-1-260C-UNLIM	
SN65HVD485EDR	ACTIVE	SOIC	D	8	2500	Green (RoHS & no Sb/Br)	CU NIPDAU	Level-1-260C-UNLIM	
SN65HVD485EDRG4	ACTIVE	SOIC	D	8	2500	Green (RoHS & no Sb/Br)	CU NIPDAU	Level-1-260C-UNLIM	
SN65HVD485EP	ACTIVE	PDIP	P	8	50	Pb-Free (RoHS)	CU NIPDAU	N / A for Pkg Type	
SN65HVD485EPE4	ACTIVE	PDIP	P	8	50	Pb-Free (RoHS)	CU NIPDAU	N / A for Pkg Type	

<sup>(1)</sup> The marketing status values are defined as follows:

**ACTIVE:** Product device recommended for new designs.

**LIFEBUY:** TI has announced that the device will be discontinued, and a lifetime-buy period is in effect.

**NRND:** Not recommended for new designs. Device is in production to support existing customers, but TI does not recommend using this part in a new design.

**PREVIEW:** Device has been announced but is not in production. Samples may or may not be available.

**OBSOLETE:** TI has discontinued the production of the device.

<sup>(2)</sup> Eco Plan - The planned eco-friendly classification: Pb-Free (RoHS), Pb-Free (RoHS Exempt), or Green (RoHS & no Sb/Br) - please check <http://www.ti.com/productcontent> for the latest availability information and additional product content details.

**TBD:** The Pb-Free/Green conversion plan has not been defined.

**Pb-Free (RoHS):** TI's terms "Lead-Free" or "Pb-Free" mean semiconductor products that are compatible with the current RoHS requirements for all 6 substances, including the requirement that lead not exceed 0.1% by weight in homogeneous materials. Where designed to be soldered at high temperatures, TI Pb-Free products are suitable for use in specified lead-free processes.

**Pb-Free (RoHS Exempt):** This component has a RoHS exemption for either 1) lead-based flip-chip solder bumps used between the die and package, or 2) lead-based die adhesive used between the die and leadframe. The component is otherwise considered Pb-Free (RoHS compatible) as defined above.

**Green (RoHS & no Sb/Br):** TI defines "Green" to mean Pb-Free (RoHS compatible), and free of Bromine (Br) and Antimony (Sb) based flame retardants (Br or Sb do not exceed 0.1% by weight in homogeneous material)

<sup>(3)</sup> MSL, Peak Temp. -- The Moisture Sensitivity Level rating according to the JEDEC industry standard classifications, and peak solder temperature.

**Important Information and Disclaimer:** The information provided on this page represents TI's knowledge and belief as of the date that it is provided. TI bases its knowledge and belief on information provided by third parties, and makes no representation or warranty as to the accuracy of such information. Efforts are underway to better integrate information from third parties. TI has taken and continues to take reasonable steps to provide representative and accurate information but may not have conducted destructive testing or chemical analysis on incoming materials and chemicals. TI and TI suppliers consider certain information to be proprietary, and thus CAS numbers and other limited information may not be available for release.

In no event shall TI's liability arising out of such information exceed the total purchase price of the TI part(s) at issue in this document sold by TI to Customer on an annual basis.

**TAPE AND REEL INFORMATION**
**REEL DIMENSIONS**

**TAPE DIMENSIONS**

A0	Dimension designed to accommodate the component width
B0	Dimension designed to accommodate the component length
K0	Dimension designed to accommodate the component thickness
W	Overall width of the carrier tape
P1	Pitch between successive cavity centers

**TAPE AND REEL INFORMATION**

\*All dimensions are nominal

Device	Package Type	Package Drawing	Pins	SPQ	Reel Diameter (mm)	Reel Width W1 (mm)	A0 (mm)	B0 (mm)	K0 (mm)	P1 (mm)	W (mm)	Pin1 Quadrant
SN65HVD485EDGKR	VSSOP	DGK	8	2500	330.0	12.4	5.3	3.4	1.4	8.0	12.0	Q1
SN65HVD485EDR	SOIC	D	8	2500	330.0	12.4	6.4	5.2	2.1	8.0	12.0	Q1

**TAPE AND REEL BOX DIMENSIONS**

\*All dimensions are nominal

Device	Package Type	Package Drawing	Pins	SPQ	Length (mm)	Width (mm)	Height (mm)
SN65HVD485EDGKR	VSSOP	DGK	8	2500	367.0	367.0	35.0
SN65HVD485EDR	SOIC	D	8	2500	340.5	338.1	20.6

P (R-PDIP-T8)

PLASTIC DUAL-IN-LINE PACKAGE

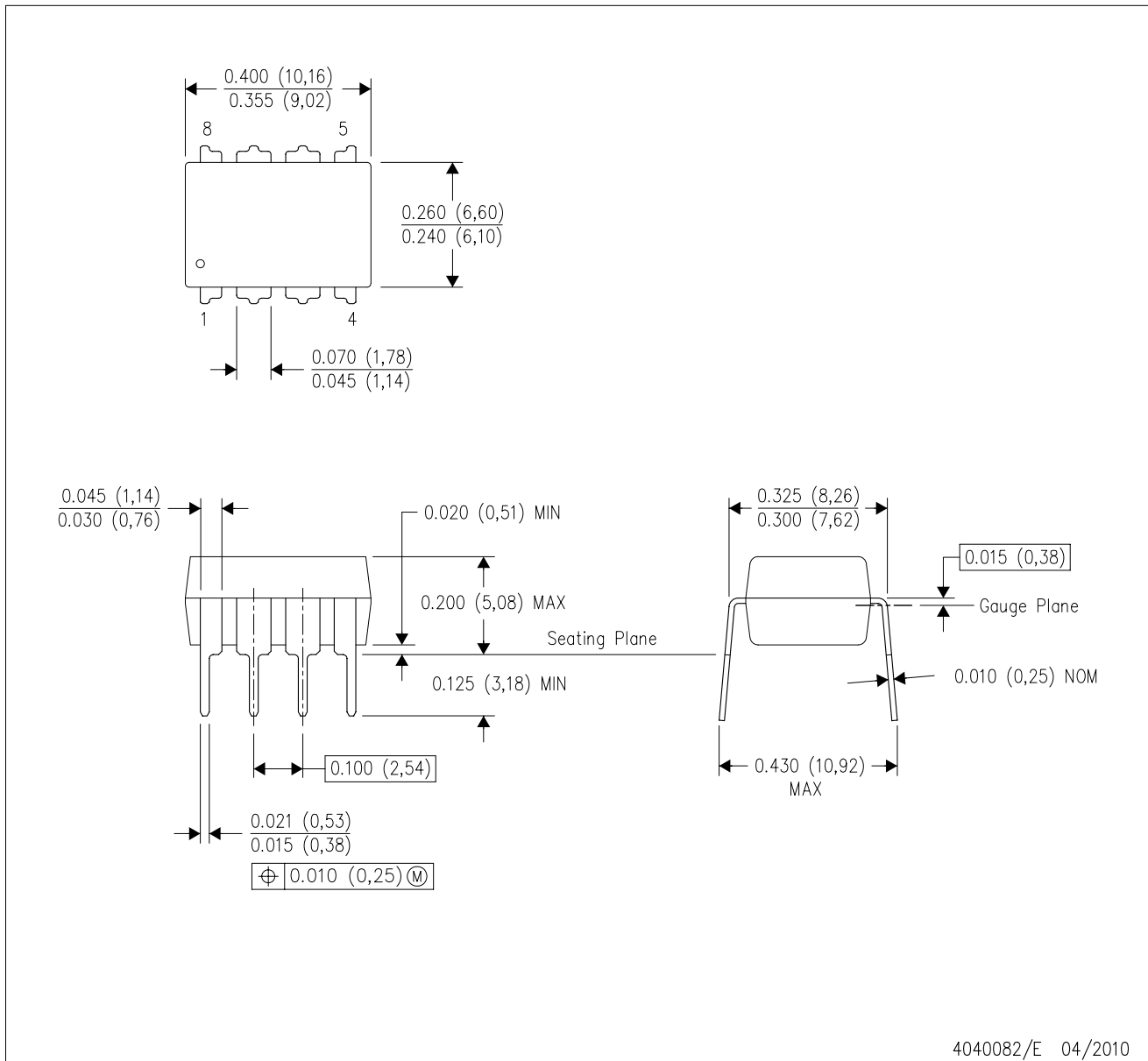

4040082/E 04/2010

- NOTES:
- A. All linear dimensions are in inches (millimeters).
  - B. This drawing is subject to change without notice.
  - C. Falls within JEDEC MS-001 variation BA.

DGK (S-PDSO-G8)

PLASTIC SMALL-OUTLINE PACKAGE



4073329/E 05/06

- NOTES:
- A. All linear dimensions are in millimeters.
  - B. This drawing is subject to change without notice.
  - C. Body length does not include mold flash, protrusions, or gate burrs. Mold flash, protrusions, or gate burrs shall not exceed 0.15 per end.
  - D. Body width does not include interlead flash. Interlead flash shall not exceed 0.50 per side.
  - E. Falls within JEDEC MO-187 variation AA, except interlead flash.

D (R-PDSO-G8)

PLASTIC SMALL OUTLINE

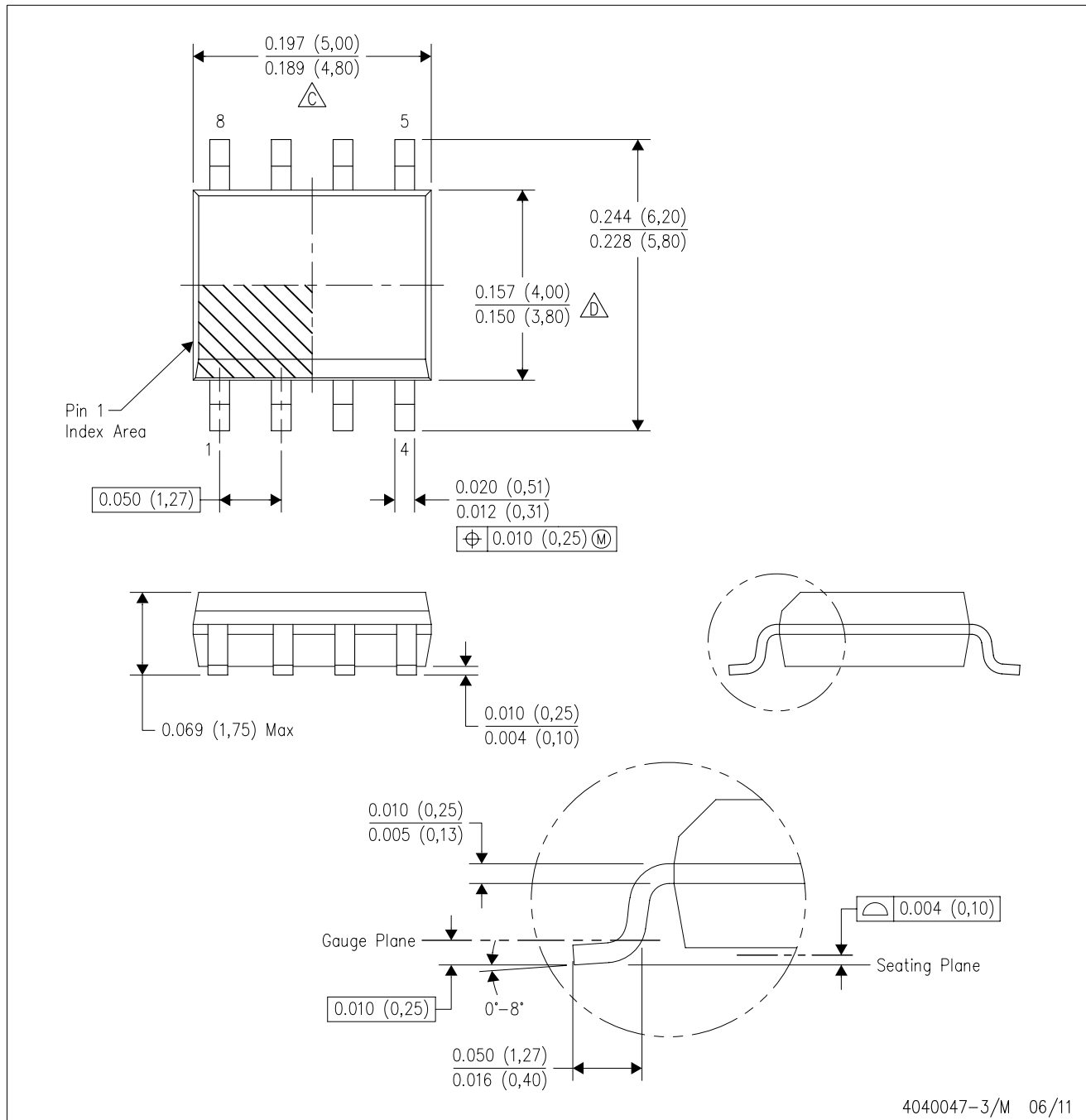

- NOTES:
- A. All linear dimensions are in inches (millimeters).
  - B. This drawing is subject to change without notice.
  - C. Body length does not include mold flash, protrusions, or gate burrs. Mold flash, protrusions, or gate burrs shall not exceed 0.006 (0,15) each side.
  - D. Body width does not include interlead flash. Interlead flash shall not exceed 0.017 (0,43) each side.
  - E. Reference JEDEC MS-012 variation AA.

D (R-PDSO-G8)

PLASTIC SMALL OUTLINE

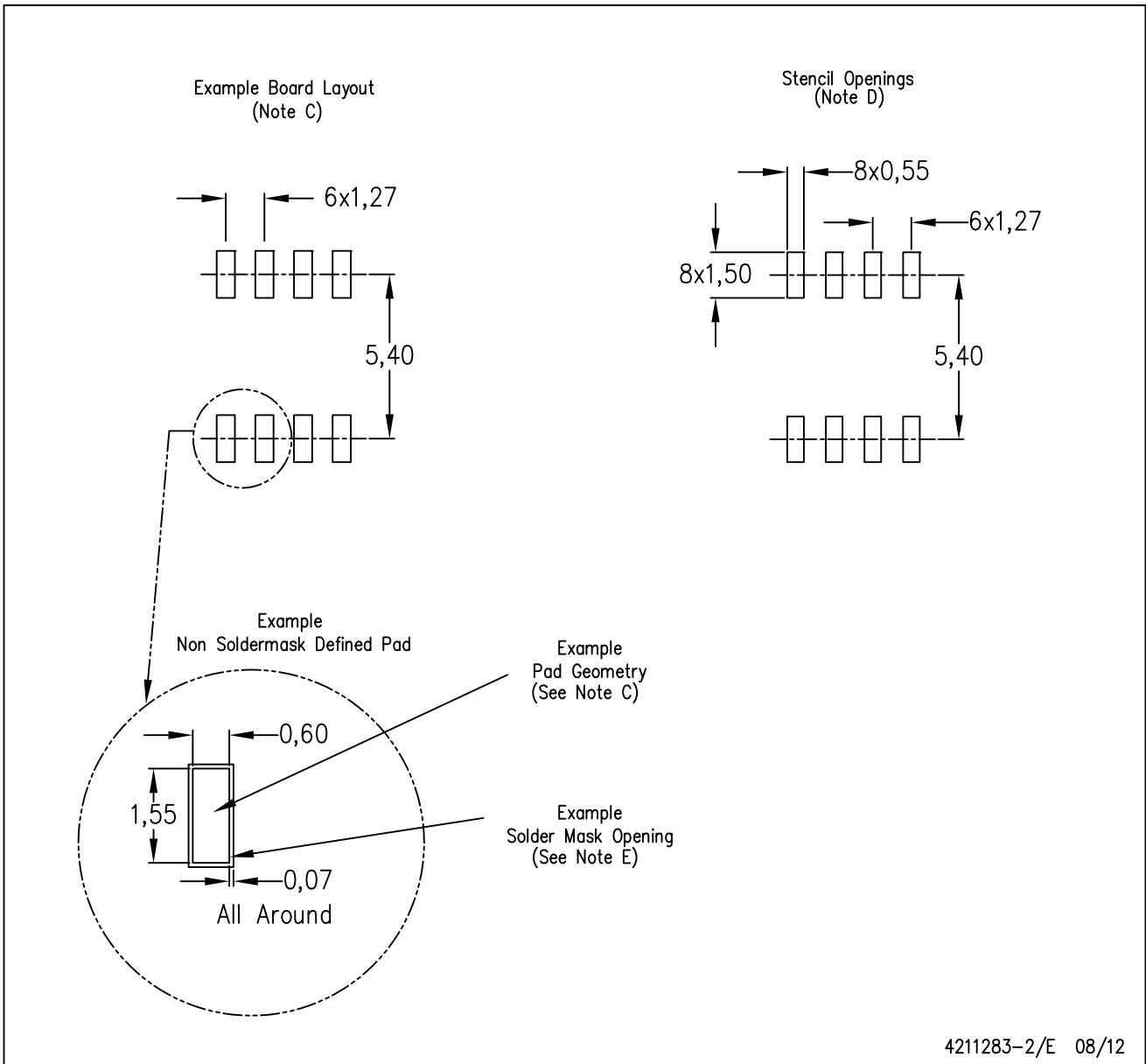

- NOTES:
- A. All linear dimensions are in millimeters.
  - B. This drawing is subject to change without notice.
  - C. Publication IPC-7351 is recommended for alternate designs.
  - D. Laser cutting apertures with trapezoidal walls and also rounding corners will offer better paste release. Customers should contact their board assembly site for stencil design recommendations. Refer to IPC-7525 for other stencil recommendations.
  - E. Customers should contact their board fabrication site for solder mask tolerances between and around signal pads.

## IMPORTANT NOTICE

Texas Instruments Incorporated and its subsidiaries (TI) reserve the right to make corrections, enhancements, improvements and other changes to its semiconductor products and services per JESD46, latest issue, and to discontinue any product or service per JESD48, latest issue. Buyers should obtain the latest relevant information before placing orders and should verify that such information is current and complete. All semiconductor products (also referred to herein as "components") are sold subject to TI's terms and conditions of sale supplied at the time of order acknowledgment.

TI warrants performance of its components to the specifications applicable at the time of sale, in accordance with the warranty in TI's terms and conditions of sale of semiconductor products. Testing and other quality control techniques are used to the extent TI deems necessary to support this warranty. Except where mandated by applicable law, testing of all parameters of each component is not necessarily performed.

TI assumes no liability for applications assistance or the design of Buyers' products. Buyers are responsible for their products and applications using TI components. To minimize the risks associated with Buyers' products and applications, Buyers should provide adequate design and operating safeguards.

TI does not warrant or represent that any license, either express or implied, is granted under any patent right, copyright, mask work right, or other intellectual property right relating to any combination, machine, or process in which TI components or services are used. Information published by TI regarding third-party products or services does not constitute a license to use such products or services or a warranty or endorsement thereof. Use of such information may require a license from a third party under the patents or other intellectual property of the third party, or a license from TI under the patents or other intellectual property of TI.

Reproduction of significant portions of TI information in TI data books or data sheets is permissible only if reproduction is without alteration and is accompanied by all associated warranties, conditions, limitations, and notices. TI is not responsible or liable for such altered documentation. Information of third parties may be subject to additional restrictions.

Resale of TI components or services with statements different from or beyond the parameters stated by TI for that component or service voids all express and any implied warranties for the associated TI component or service and is an unfair and deceptive business practice. TI is not responsible or liable for any such statements.

Buyer acknowledges and agrees that it is solely responsible for compliance with all legal, regulatory and safety-related requirements concerning its products, and any use of TI components in its applications, notwithstanding any applications-related information or support that may be provided by TI. Buyer represents and agrees that it has all the necessary expertise to create and implement safeguards which anticipate dangerous consequences of failures, monitor failures and their consequences, lessen the likelihood of failures that might cause harm and take appropriate remedial actions. Buyer will fully indemnify TI and its representatives against any damages arising out of the use of any TI components in safety-critical applications.

In some cases, TI components may be promoted specifically to facilitate safety-related applications. With such components, TI's goal is to help enable customers to design and create their own end-product solutions that meet applicable functional safety standards and requirements. Nonetheless, such components are subject to these terms.

No TI components are authorized for use in FDA Class III (or similar life-critical medical equipment) unless authorized officers of the parties have executed a special agreement specifically governing such use.

Only those TI components which TI has specifically designated as military grade or "enhanced plastic" are designed and intended for use in military/aerospace applications or environments. Buyer acknowledges and agrees that any military or aerospace use of TI components which have **not** been so designated is solely at the Buyer's risk, and that Buyer is solely responsible for compliance with all legal and regulatory requirements in connection with such use.

TI has specifically designated certain components which meet ISO/TS16949 requirements, mainly for automotive use. Components which have not been so designated are neither designed nor intended for automotive use; and TI will not be responsible for any failure of such components to meet such requirements.

### Products

Audio	<a href="http://www.ti.com/audio">www.ti.com/audio</a>
Amplifiers	<a href="http://amplifier.ti.com">amplifier.ti.com</a>
Data Converters	<a href="http://dataconverter.ti.com">dataconverter.ti.com</a>
DLP® Products	<a href="http://www.dlp.com">www.dlp.com</a>
DSP	<a href="http://dsp.ti.com">dsp.ti.com</a>
Clocks and Timers	<a href="http://www.ti.com/clocks">www.ti.com/clocks</a>
Interface	<a href="http://interface.ti.com">interface.ti.com</a>
Logic	<a href="http://logic.ti.com">logic.ti.com</a>
Power Mgmt	<a href="http://power.ti.com">power.ti.com</a>
Microcontrollers	<a href="http://microcontroller.ti.com">microcontroller.ti.com</a>
RFID	<a href="http://www.ti-rfid.com">www.ti-rfid.com</a>
OMAP Applications Processors	<a href="http://www.ti.com/omap">www.ti.com/omap</a>
Wireless Connectivity	<a href="http://www.ti.com/wirelessconnectivity">www.ti.com/wirelessconnectivity</a>

### Applications

Automotive and Transportation	<a href="http://www.ti.com/automotive">www.ti.com/automotive</a>
Communications and Telecom	<a href="http://www.ti.com/communications">www.ti.com/communications</a>
Computers and Peripherals	<a href="http://www.ti.com/computers">www.ti.com/computers</a>
Consumer Electronics	<a href="http://www.ti.com/consumer-apps">www.ti.com/consumer-apps</a>
Energy and Lighting	<a href="http://www.ti.com/energy">www.ti.com/energy</a>
Industrial	<a href="http://www.ti.com/industrial">www.ti.com/industrial</a>
Medical	<a href="http://www.ti.com/medical">www.ti.com/medical</a>
Security	<a href="http://www.ti.com/security">www.ti.com/security</a>
Space, Avionics and Defense	<a href="http://www.ti.com/space-avionics-defense">www.ti.com/space-avionics-defense</a>
Video and Imaging	<a href="http://www.ti.com/video">www.ti.com/video</a>

### TI E2E Community

[e2e.ti.com](http://e2e.ti.com)