

Dual Full Bridge PWM Motor Driver

Check for Samples: [DRV8412](#) [DRV8422](#) [DRV8432](#)

FEATURES

- **High-Efficiency Power Stage (up to 97%) with Low $R_{DS(on)}$ MOSFETs (80 m Ω at $T_J = 25^\circ\text{C}$)**
- **Operating Supply Voltage up to 50 V (70 V Absolute Maximum)**
- **DRV8412 (power pad down): up to 2 x 3 A Continuous Output Current (2 x 6 A Peak) in Dual Full Bridge Mode or 6 A Continuous Current in Parallel Mode (12 A Peak)**
- **DRV8422 (power pad up): up to 2 x 5 A Continuous Output Current (2 x 9 A Peak) in Dual Full Bridge Mode or 10 A Continuous Current in Parallel Mode (18 A Peak)**
- **DRV8432 (power pad up): up to 2 x 7 A Continuous Output Current (2 x 12 A Peak) in Dual Full Bridge Mode or 14 A Continuous Current in Parallel Mode (24 A Peak)**
- **PWM Operating Frequency up to 500 kHz**
- **Integrated Self-Protection Circuits Including Undervoltage, Overtemperature, Overload, and Short Circuit**
- **Programmable Cycle-by-Cycle Current Limit Protection**
- **Independent Supply and Ground Pins for Each Half Bridge**
- **Intelligent Gate Drive and Cross Conduction Prevention**
- **No External Snubber or Schottky Diode is Required**

APPLICATIONS

- **Brushed DC and Stepper Motors**
- **Three Phase Permanent Magnet Synchronous Motors**
- **Robotic and Haptic Control System**
- **Actuators and Pumps**
- **Precision Instruments**
- **TEC Drivers**

DESCRIPTION

The DRV8412/22/32 are high performance, integrated dual full bridge motor drivers with an advanced protection system.

Because of the low $R_{DS(on)}$ of the H-Bridge MOSFETs and intelligent gate drive design, the efficiency of these motor drivers can be up to 97%, which enables the use of smaller power supplies and heatsinks, and are good candidates for energy efficient applications.

The DRV8412/22/32 require two power supplies, one at 12 V for GVDD and VDD, and another up to 50 V for PVDD. The DRV8412/22/32 can operate at up to 500-kHz switching frequency while still maintain precise control and high efficiency. They also have an innovative protection system safeguarding the device against a wide range of fault conditions that could damage the system. These safeguards are short-circuit protection, overcurrent protection, undervoltage protection, and two-stage thermal protection. The DRV8412/22/32 have a current-limiting circuit that prevents device shutdown during load transients such as motor start-up. A programmable overcurrent detector allows adjustable current limit and protection level to meet different motor requirements.

The DRV8412/22/32 have unique independent supply and ground pins for each half bridge, which makes it possible to provide current measurement through external shunt resistor and support multiple motors with different power supply voltage requirements.

Simplified Application Diagram

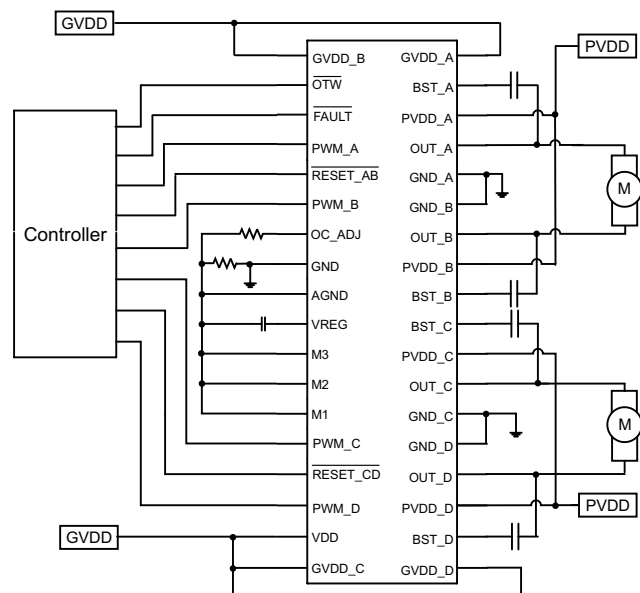

Please be aware that an important notice concerning availability, standard warranty, and use in critical applications of Texas Instruments semiconductor products and disclaimers thereto appears at the end of this data sheet.



This integrated circuit can be damaged by ESD. Texas Instruments recommends that all integrated circuits be handled with appropriate precautions. Failure to observe proper handling and installation procedures can cause damage.

ESD damage can range from subtle performance degradation to complete device failure. Precision integrated circuits may be more susceptible to damage because very small parametric changes could cause the device not to meet its published specifications.

ABSOLUTE MAXIMUM RATINGS

Over operating free-air temperature range unless otherwise noted ⁽¹⁾

	VALUE
VDD to GND	-0.3 V to 13.2 V
GVDD_X to GND	-0.3 V to 13.2 V
PVDD_X to GND_X ⁽²⁾	-0.3 V to 70 V
OUT_X to GND_X ⁽²⁾	-0.3 V to 70 V
BST_X to GND_X ⁽²⁾	-0.3 V to 80 V
Transient peak output current (per pin), pulse width limited by internal over-current protection circuit.	16 A
Transient peak output current for latch shut down (per pin)	20 A
VREG to AGND	-0.3 V to 4.2 V
GND_X to GND	-0.3 V to 0.3 V
GND to AGND	-0.3 V to 0.3 V
PWM_X to GND	-0.3 V to 4.2 V
OC_ADJ, M1, M2, M3 to AGND	-0.3 V to 4.2 V
RESET_X, FAULT, OTW to GND	-0.3 V to 7 V
Maximum continuous sink current (FAULT, OTW)	9 mA
Maximum operating junction temperature range, T _{OP}	-40°C to 150°C
Storage temperature, T _{STG}	-55°C to 150°C

- (1) Stresses beyond those listed under *Absolute Maximum Ratings* may cause permanent damage to the device. These are stress ratings only, and functional operation of the device at these or any other conditions beyond those indicated under *Recommended Operating Conditions* is not implied. Exposure to absolute-maximum-rated conditions for extended periods may affect device reliability.
- (2) These voltages represent the dc voltage + peak ac waveform measured at the terminal of the device in all conditions.

RECOMMENDED OPERATING CONDITIONS

		MIN	NOM	MAX	UNIT
PVDD_X	Half bridge X (A, B, C, or D) DC supply voltage	0	50	52.5	V
GVDD_X	Supply for logic regulators and gate-drive circuitry	10.8	12	13.2	V
VDD	Digital regulator supply voltage	10.8	12	13.2	V
I _{O_PULSE}	Pulsed peak current per output pin (could be limited by thermal)			15	A
I _O	Continuous current per output pin (DRV8432)			7	A
F _{SW}	PWM switching frequency			500	kHz
R _{OCP_CBC}	OC programming resistor range in cycle-by-cycle current limit modes	24		200	kΩ
R _{OCP_OCL}	OC programming resistor range in OC latching shutdown modes	22		200	kΩ
C _{BST}	Bootstrap capacitor range	33		220	nF
T _{ON_MIN}	Minimum PWM pulse duration, low		50		nS
T _J	Operating junction temperature	-40		125	°C

PACKAGE HEAT DISSIPATION RATINGS

PARAMETER	DRV8412	DRV8422	DRV8432
$R_{\theta JC}$, junction-to-case (power pad / heat slug) thermal resistance	1.1 °C/W	1.1 °C/W	0.9 °C/W
$R_{\theta JA}$, junction-to-ambient thermal resistance	25 °C/W	This device is not intended to be used without a heatsink. Therefore, $R_{\theta JA}$ is not specified. See the <i>Thermal Information</i> section.	This device is not intended to be used without a heatsink. Therefore, $R_{\theta JA}$ is not specified. See the <i>Thermal Information</i> section.
Exposed power pad / heat slug area	34 mm ²	34 mm ²	80 mm ²

PACKAGE POWER DERATINGS (DRV8412)⁽¹⁾

PACKAGE	$T_A = 25^\circ\text{C}$ POWER RATING	DERATING FACTOR ABOVE $T_A = 25^\circ\text{C}$	$T_A = 70^\circ\text{C}$ POWER RATING	$T_A = 85^\circ\text{C}$ POWER RATING
44-PIN TSSOP (DDW)	5.0 W	40.0 mW/°C	3.2 W	2.6 W

(1) Based on EVM board layout

MODE SELECTION PINS

MODE PINS			OUTPUT CONFIGURATION	DESCRIPTION
M3	M2	M1		
0	0	0	2 FB or 4 HB	Dual full bridges (two PWM inputs each full bridge) or four half bridges with cycle-by-cycle current limit
0	0	1	2 FB or 4 HB	Dual full bridges (two PWM inputs each full bridge) or four half bridges with OC latching shutdown (no cycle-by-cycle current limit)
0	1	0	1 PFB	Parallel full bridge with cycle-by-cycle current limit
0	1	1	2 FB	Dual full bridges (one PWM input each full bridge with complementary PWM on second half bridge) with cycle-by-cycle current limit
1	x	x		Reserved

DEVICE INFORMATION

Pin Assignment

Here are the pinouts for the DRV8412/22/32:

- DRV8412: 44-pin TSSOP power pad down DDW package. This package contains a thermal pad that is located on the bottom side of the device for dissipating heat through PCB.
- DRV8422: 44-pin TSSOP power pad up DDV package. This package contains a thermal pad that is located on the top side of the device for dissipating heat through heatsink.
- DRV8432: 36-pin PSOP3 DKD package. This package contains a thick heat slug that is located on the top side of the device for dissipating heat through heatsink.

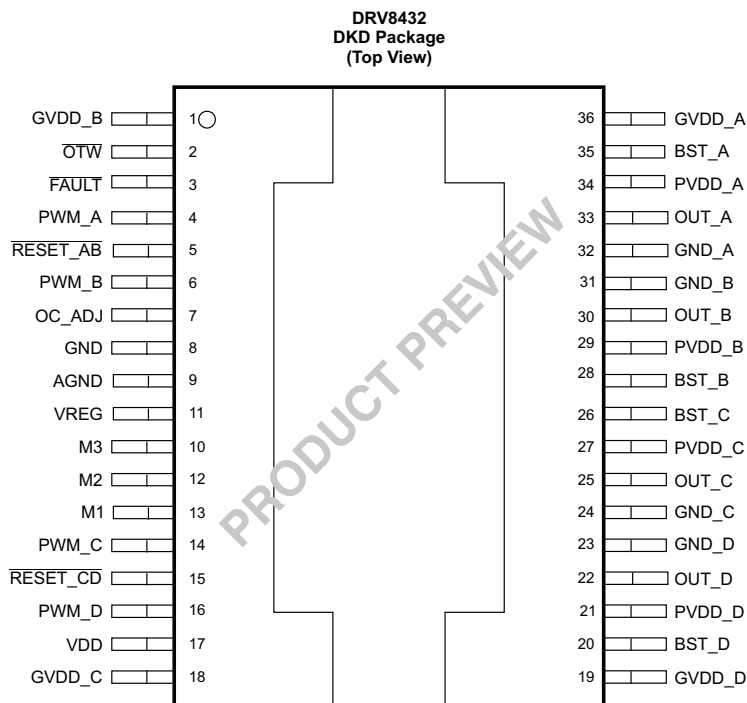
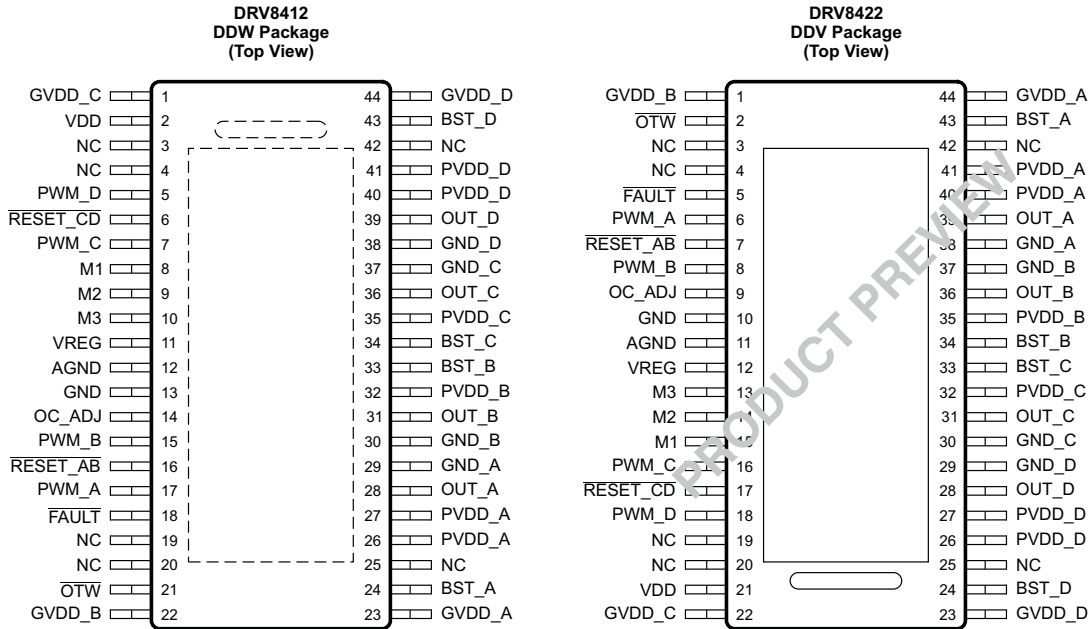

Pin Functions

NAME	PIN			FUNCTION (1)	DESCRIPTION
	DRV8412	DRV8422	DRV8432		
AGND	12	11	9	P	Analog ground
BST_A	24	43	35	P	High side bootstrap supply (BST), external capacitor to OUT_A required
BST_B	33	34	28	P	High side bootstrap supply (BST), external capacitor to OUT_B required
BST_C	34	33	27	P	High side bootstrap supply (BST), external capacitor to OUT_C required
BST_D	43	24	20	P	High side bootstrap supply (BST), external capacitor to OUT_D required
GND	13	10	8	P	Ground
GND_A	29	38	32	P	Power ground for half-bridge A requires close decoupling capacitor to ground
GND_B	30	37	31	P	Power ground for half-bridge B requires close decoupling capacitor to ground
GND_C	37	30	24	P	Power ground for half-bridge C requires close decoupling capacitor to ground
GND_D	38	29	23	P	Power ground for half-bridge D requires close decoupling capacitor to ground
GVDD_A	23	44	36	P	Gate-drive voltage supply
GVDD_B	22	1	1	P	Gate-drive voltage supply
GVDD_C	1	22	18	P	Gate-drive voltage supply
GVDD_D	44	23	19	P	Gate-drive voltage supply
M1	8	15	13	I	Mode selection pin
M2	9	14	12	I	Mode selection pin
M3	10	13	11	I	Reserved mode selection pin, AGND connection is recommended
NC	3,4,19,20,25,42	3,4,19,20,25,42	-	-	No connection pin. Ground connection is recommended
OC_ADJ	14	9	7	O	Analog overcurrent programming pin, requires resistor to AGND
$\overline{\text{OTW}}$	21	2	2	O	Overtemperature warning signal, open-drain, active-low. An internal pull-up resistor to VREG (3.3 V) is provided on output. Level compliance for 5-V logic can be obtained by adding external pull-up resistor to 5 V
OUT_A	28	39	33	O	Output, half-bridge A
OUT_B	31	36	30	O	Output, half-bridge B
OUT_C	36	31	25	O	Output, half-bridge C
OUT_D	39	28	22	O	Output, half-bridge D
PVDD_A	26,27	40,41	34	P	Power supply input for half-bridge A requires close decoupling capacitor to ground.
PVDD_B	32	35	29	P	Power supply input for half-bridge B requires close decoupling capacitor to ground.
PVDD_C	35	32	26	P	Power supply input for half-bridge C requires close decoupling capacitor to ground.
PVDD_D	40,41	26,27	21	P	Power supply input for half-bridge D requires close decoupling capacitor to ground.
PWM_A	17	6	4	I	Input signal for half-bridge A
PWM_B	15	8	6	I	Input signal for half-bridge B
PWM_C	7	16	14	I	Input signal for half-bridge C
PWM_D	5	18	16	I	Input signal for half-bridge D
$\overline{\text{RESET_AB}}$	16	7	5	I	Reset signal for half-bridge A and half-bridge B, active-low
$\overline{\text{RESET_CD}}$	6	17	15	I	Reset signal for half-bridge C and half-bridge D, active-low
$\overline{\text{FAULT}}$	18	5	3	O	Fault signal, open-drain, active-low. An internal pull-up resistor to VREG (3.3 V) is provided on output. Level compliance for 5-V logic can be obtained by adding external pull-up resistor to 5 V
VDD	2	21	17	P	Power supply for digital voltage regulator requires caacitor to ground for decoupling.
VREG	11	12	10	P	Digital regulator supply filter pin requires 0.1- μF capacitor to AGND.

(1) I = input, O = output, P = power

SYSTEM BLOCK DIAGRAM

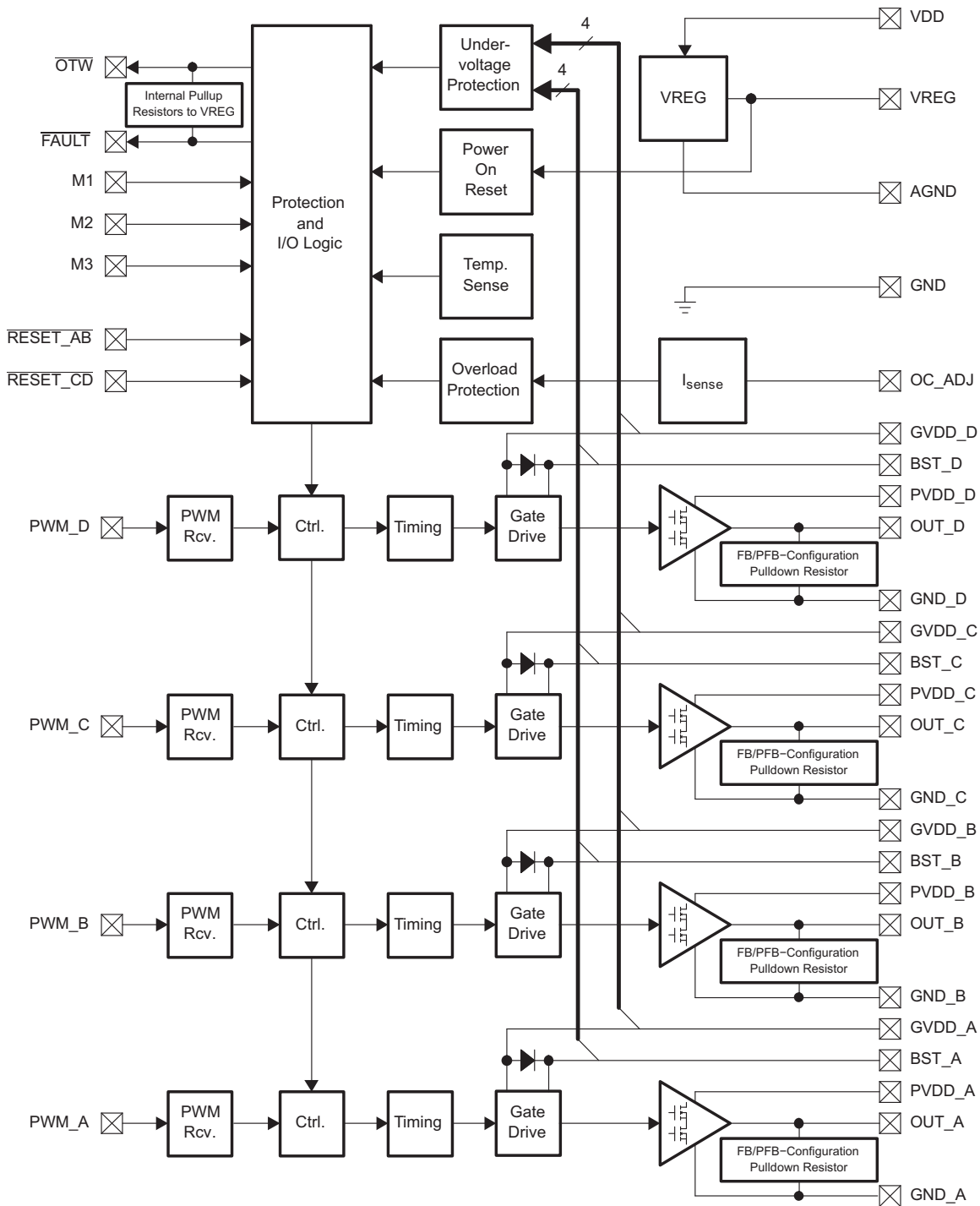

ELECTRICAL CHARACTERISTICS

$T_A = 25^\circ\text{C}$, $PVDD = 50\text{ V}$, $GVDD = VDD = 12\text{ V}$, $f_{\text{sw}} = 400\text{ kHz}$, unless otherwise noted. All performance is in accordance with recommended operating conditions unless otherwise specified.

PARAMETER		TEST CONDITIONS	MIN	TYP	MAX	UNIT
Internal Voltage Regulator and Current Consumption						
V_{REG}	Voltage regulator, only used as a reference node	$VDD = 12\text{ V}$	3	3.3	3.6	V
I_{VDD}	VDD supply current	Idle, reset mode		9	12	mA
		Operating, 50% duty cycle		10.5		
I_{GVDD_X}	Gate supply current per half-bridge	Reset mode		1.7	2	mA
		Operating, 50% duty cycle		8		
I_{PVDD_X}	Half-bridge X (A, B, C, or D) idle current	Reset mode		0.7	1	mA
Output Stage						
$R_{\text{DS(on)}}$	MOSFET drain-to-source resistance, low side (LS)	$T_J = 25^\circ\text{C}$, $GVDD = 12\text{ V}$		80		m Ω
	MOSFET drain-to-source resistance, high side (HS)	$T_J = 25^\circ\text{C}$, $GVDD = 12\text{ V}$		80		m Ω
V_F	Diode forward voltage drop	$T_J = 25^\circ\text{C} - 125^\circ\text{C}$, $I_O = 5\text{ A}$		1		V
t_R	Output rise time	Resistive load, $I_O = 5\text{ A}$		14		nS
t_F	Output fall time	Resistive load, $I_O = 5\text{ A}$		14		nS
$t_{\text{PD_ON}}$	Propagation delay when FET is on	Resistive load, $I_O = 5\text{ A}$		38		nS
$t_{\text{PD_OFF}}$	Propagation delay when FET is off	Resistive load, $I_O = 5\text{ A}$		38		nS
t_{DT}	Dead time between HS and LS FETs	Resistive load, $I_O = 5\text{ A}$		5		nS
I/O Protection						
$V_{\text{uvp,G}}$	Gate supply voltage $GVDD_X$ undervoltage protection threshold			8.5		V
$V_{\text{uvp,hyst}}^{(1)}$	Hysteresis for gate supply undervoltage event			0.8		V
$OTW^{(1)}$	Overtemperature warning		115	125	135	$^\circ\text{C}$
$OTW_{\text{hyst}}^{(1)}$	Hysteresis temperature to reset OTW event			25		$^\circ\text{C}$
$OTSD^{(1)}$	Overtemperature shut down			150		$^\circ\text{C}$
$OTE-OTW_{\text{differential}}^{(1)}$	OTE-OTW overtemperature detect temperature difference			25		$^\circ\text{C}$
$OTSD_{\text{HYST}}^{(1)}$	Hysteresis temperature for $\overline{\text{FAULT}}$ to be released following an $OTSD$ event			25		$^\circ\text{C}$
I_{OC}	Overcurrent limit protection	Resistor—programmable, nominal, $R_{\text{OCP}} = 27\text{ k}\Omega$		9.7		A
I_{OCT}	Overcurrent response time	Time from application of short condition to Hi-Z of affected FET(s)		250		ns
R_{PD}	Internal pulldown resistor at the output of each half-bridge	Connected when $\overline{\text{RESET_AB}}$ or $\overline{\text{RESET_CD}}$ is active to provide bootstrap capacitor charge		1		k Ω
Static Digital Specifications						
V_{IH}	High-level input voltage	PWM_A , PWM_B , PWM_C , PWM_D , M1, M2, M3		2	3.6	V
V_{IH}	High-level input voltage	$\overline{\text{RESET_AB}}$, $\overline{\text{RESET_CD}}$		2	5.5	V
V_{IL}	Low-level input voltage	PWM_A , PWM_B , PWM_C , PWM_D , M1, M2, M3, $\overline{\text{RESET_AB}}$, $\overline{\text{RESET_CD}}$			0.8	V
I_{ikg}	Input leakage current		-100		100	μA
OTW / FAULT						
$R_{\text{INT_PU}}$	Internal pullup resistance, $\overline{\text{OTW}}$ to V_{REG} , $\overline{\text{FAULT}}$ to V_{REG}		20	26	35	k Ω
V_{OH}	High-level output voltage	Internal pullup resistor only	3	3.3	3.6	V
		External pullup of 4.7 k Ω to 5 V	4.5		5	
V_{OL}	Low-level output voltage	$I_O = 4\text{ mA}$		0.2	0.4	V

(1) Specified by design

TYPICAL CHARACTERISTICS

EFFICIENCY
 vs
 SWITCHING FREQUENCY (DRV8432)

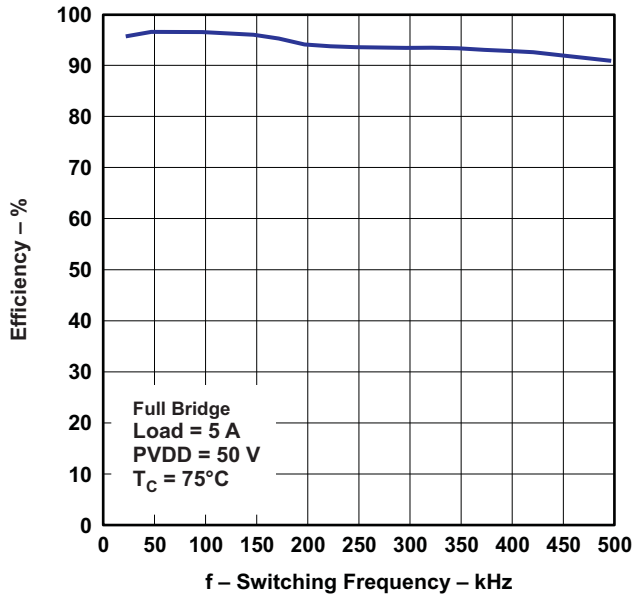

Figure 1.

NORMALIZED $R_{DS(on)}$
 vs
 GATE DRIVE

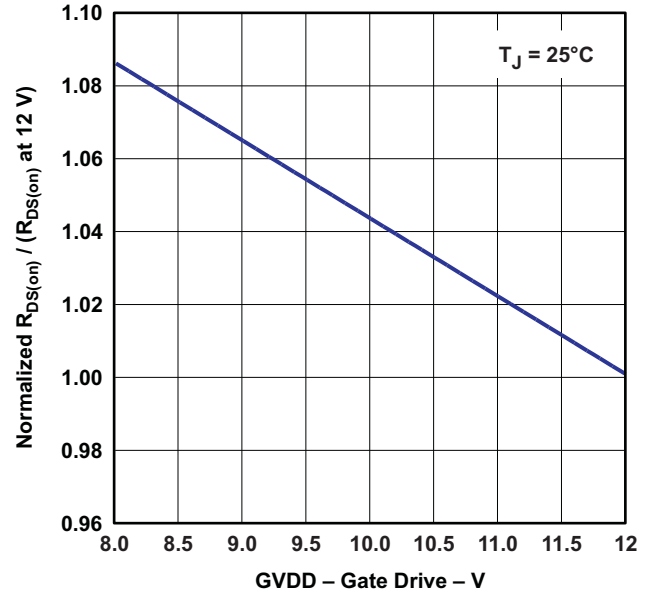

Figure 2.

NORMALIZED $R_{DS(on)}$
 vs
 JUNCTION TEMPERATURE

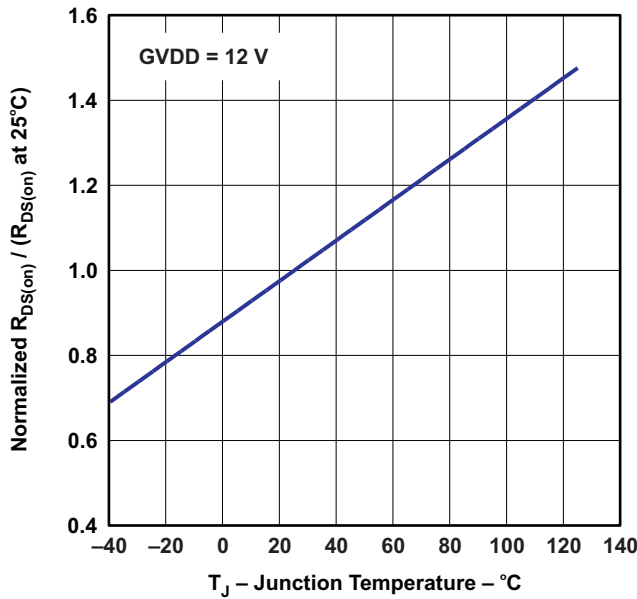

Figure 3.

DRAIN TO SOURCE DIODE FORWARD
 ON CHARACTERISTICS

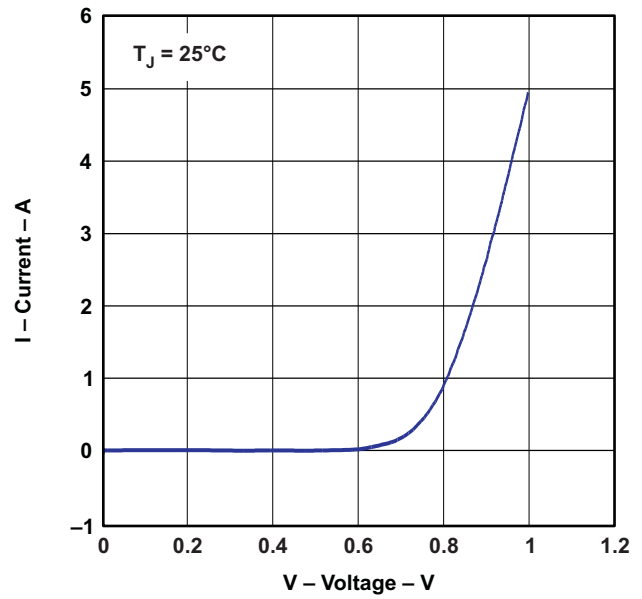

Figure 4.

TYPICAL CHARACTERISTICS (continued)

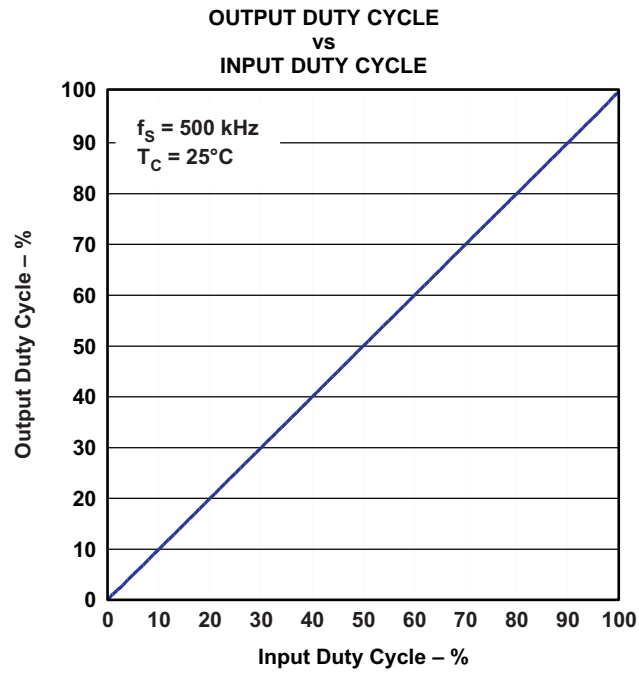

Figure 5.

THEORY OF OPERATION

POWER SUPPLIES

To facilitate system design, the DRV8412/22/32 need only a 12-V supply in addition to H-Bridge power supply (PVDD). An internal voltage regulator provides suitable voltage levels for the digital and low-voltage analog circuitry. Additionally, the high-side gate drive requiring a floating voltage supply, which is accommodated by built-in bootstrap circuitry requiring external bootstrap capacitor.

To provide symmetrical electrical characteristics, the PWM signal path, including gate drive and output stage, is designed as identical, independent half-bridges. For this reason, each half-bridge has a separate gate drive supply (GVDD_X), a bootstrap pin (BST_X), and a power-stage supply pin (PVDD_X). Furthermore, an additional pin (VDD) is provided as supply for all common circuits. Special attention should be paid to place all decoupling capacitors as close to their associated pins as possible. In general, inductance between the power supply pins and decoupling capacitors must be avoided. Furthermore, decoupling capacitors need a short ground path back to the device.

For a properly functioning bootstrap circuit, a small ceramic capacitor (an X5R or better) must be connected from each bootstrap pin (BST_X) to the power-stage output pin (OUT_X). When the power-stage output is low, the bootstrap capacitor is charged through an internal diode connected between the gate-drive power-supply pin (GVDD_X) and the bootstrap pin. When the power-stage output is high, the bootstrap capacitor potential is shifted above the output potential and thus provides a suitable voltage supply for the high-side gate driver. In an application with PWM switching frequencies in the range from 10 kHz to 500 kHz, the use of 100-nF ceramic capacitors (X5R or better), size 0603 or 0805, is recommended for the bootstrap supply. These 100-nF capacitors ensure sufficient energy storage, even during minimal PWM duty cycles, to keep the high-side power stage FET fully turned on during the remaining part of the PWM cycle. In an application running at a switching frequency lower than 10 kHz, the bootstrap capacitor might need to be increased in value.

Special attention should be paid to the power-stage power supply; this includes component selection, PCB placement, and routing. As indicated, each half-bridge has independent power-stage supply pin (PVDD_X). For optimal electrical performance, EMI

compliance, and system reliability, it is important that each PVDD_X pin is decoupled with a ceramic capacitor (X5R or better) placed as close as possible to each supply pin. It is recommended to follow the PCB layout of the DRV8412/22/32 EVM board.

The 12-V supply should be from a low-noise, low-output-impedance voltage regulator. Likewise, the 50-V power-stage supply is assumed to have low output impedance and low noise. The power-supply sequence is not critical as facilitated by the internal power-on-reset circuit. Moreover, the DRV8412/22/32 are fully protected against erroneous power-stage turn-on due to parasitic gate charging. Thus, voltage-supply ramp rates (dv/dt) are non-critical within the specified voltage range (see the *Recommended Operating Conditions* section of this data sheet).

SYSTEM POWER-UP/POWER-DOWN SEQUENCE

Powering Up

The DRV8412/22/32 do not require a power-up sequence. The outputs of the H-bridges remain in a high impedance state until the gate-drive supply voltage GVDD_X and VDD voltage are above the undervoltage protection (UVP) voltage threshold (see the *Electrical Characteristics* section of this data sheet). Although not specifically required, holding RESET_AB and RESET_CD in a low state while powering up the device is recommended. This allows an internal circuit to charge the external bootstrap capacitors by enabling a weak pulldown of the half-bridge output.

Powering Down

The DRV8412/22/32 do not require a power-down sequence. The device remains fully operational as long as the gate-drive supply (GVDD_X) voltage and VDD voltage are above the UVP voltage threshold (see the *Electrical Characteristics* section of this data sheet). Although not specifically required, it is a good practice to hold RESET_AB and RESET_CD low during power down to prevent any unknown state during this transition.

ERROR REPORTING

The $\overline{\text{FAULT}}$ and $\overline{\text{OTW}}$ pins are both active-low, open-drain outputs. Their function is for protection-mode signaling to a PWM controller or other system-control device.

Any fault resulting in device shutdown, such as overtemperature shut down, overcurrent shut-down, or undervoltage protection, is signaled by the $\overline{\text{FAULT}}$ pin going low. Likewise, $\overline{\text{OTW}}$ goes low when the device junction temperature exceeds 125°C (see [Table 1](#)).

Table 1. Protection Mode Signal Descriptions

$\overline{\text{FAULT}}$	$\overline{\text{OTW}}$	DESCRIPTION
0	0	Overtemperature warning and (overtemperature shut down or overcurrent shut down or undervoltage protection) occurred
0	1	Overcurrent shut-down or GVDD undervoltage protection occurred
1	0	Overtemperature warning
1	1	Device under normal operation

TI recommends monitoring the $\overline{\text{OTW}}$ signal using the system microcontroller and responding to an $\overline{\text{OTW}}$ signal by reducing the load current to prevent further heating of the device resulting in device overtemperature shutdown (OTSD).

To reduce external component count, an internal pullup resistor to VREG (3.3 V) is provided on both $\overline{\text{FAULT}}$ and $\overline{\text{OTW}}$ outputs. Level compliance for 5-V logic can be obtained by adding external pull-up resistors to 5 V (see the *Electrical Characteristics* section of this data sheet for further specifications).

DEVICE PROTECTION SYSTEM

The DRV8412/22/32 contain advanced protection circuitry carefully designed to facilitate system integration and ease of use, as well as to safeguard the device from permanent failure due to a wide range of fault conditions such as short circuits, overcurrent, overtemperature, and undervoltage. The DRV8412/22/32 respond to a fault by immediately setting the half bridge outputs in a high-impedance (Hi-Z) state and asserting the $\overline{\text{FAULT}}$ pin low. In situations other than overcurrent or overtemperature, the device automatically recovers when the fault condition has been removed or the gate supply voltage has increased. For highest possible reliability, reset the device externally no sooner than 1 second after the shutdown when recovering from an overcurrent shut down (OCSD) or OTSD fault.

Bootstrap Capacitor Under Voltage Protection

When the device runs at a low switching frequency (e.g. less than 10 kHz with a 100-nF bootstrap capacitor), the bootstrap capacitor voltage might not be able to maintain a proper voltage level for the high-side gate driver. A bootstrap capacitor undervoltage protection circuit (BST_UVP) will prevent potential failure of the high-side MOSFET. When the voltage on the bootstrap capacitors is less than the required value for safe operation, the DRV8412/22/32 will initiate bootstrap capacitor recharge sequences (turn off high side FET for a short period) until the bootstrap capacitors are properly charged for safe operation. This function may also be activated when PWM duty cycle is too high (e.g. less than 20 ns off time at 10 kHz). Note that bootstrap capacitor might not be able to be charged if no load or extremely light load is presented at output during BST_UVP operation, so it is recommended to turn on the low side FET for at least 50 ns for each PWM cycle to avoid BST_UVP operation if possible.

Overcurrent (OC) Protection

The DRV8412/22/32 have independent, fast-reacting current detectors with programmable trip threshold (OC threshold) on all high-side and low-side power-stage FETs. There are two settings for OC protection through mode selection pins: cycle-by-cycle (CBC) current limiting mode and OC latching (OCL) shut down mode.

In CBC current limiting mode, the detector outputs are monitored by two protection systems. The first protection system controls the power stage in order to prevent the output current from further increasing, i.e., it performs a CBC current-limiting function rather than prematurely shutting down the device. This feature could effectively limit the inrush current during motor start-up or transient without damaging the device. During short to power and short to ground conditions, the current limit circuitry might not be able to control the current to a proper level, a second protection system triggers a latching shutdown, resulting in the related half bridge being set in the high-impedance (Hi-Z) state. Current limiting and overcurrent protection are independent for half-bridges A, B, C, and, D, respectively.

[Figure 6](#) illustrates cycle-by-cycle operation with high side OC event and [Figure 7](#) shows cycle-by-cycle operation with low side OC. Dashed lines are the operation waveforms when no CBC event is triggered and solid lines show the waveforms when CBC event is triggered. In CBC current limiting mode, when low side FET OC is detected, device will turn

off the affected low side FET and keep the high side FET at the same half bridge off until next PWM cycle; when high side FET OC is detected, device will turn off the affected high side FET and turn on the low side FET at the half bridge until next PWM cycle.

In OC latching shut down mode, the CBC current limit and error recovery circuitries are disabled and an overcurrent condition will cause the device to shutdown immediately. After shutdown, `RESET_AB` and/or `RESET_CD` must be asserted to restore normal operation after the overcurrent condition is removed.

For added flexibility, the OC threshold is programmable using a single external resistor connected between the `OC_ADJ` pin and GND pin. See [Table 2](#) for information on the correlation between programming-resistor value and the OC threshold. It should be noted that a properly functioning overcurrent detector assumes the presence of a proper inductor or power ferrite bead at the power-stage output. Short-circuit protection is not guaranteed with direct short at the output pins of the power stage.

Table 2. Programming-Resistor Values and OC Threshold

OC-ADJUST RESISTOR VALUES (kΩ)	MAXIMUM CURRENT BEFORE OC OCCURS (A)
22 ⁽¹⁾	11.6
24	10.7
27	9.7
30	8.8
36	7.4
39	6.9
43	6.3
47	5.8
56	4.9
68	4.1
82	3.4
100	2.8
120	2.4
150	1.9
200	1.4

(1) Recommended to use in OC Latching Mode Only

Overtemperature Protection

The DRV8412/22/32 have a two-level temperature-protection system that asserts an active-low warning signal (`OTW`) when the device junction temperature exceeds 125°C (nominal) and, if the device junction temperature exceeds 150°C (nominal), the device is put into thermal shutdown, resulting in all half-bridge outputs being set in the high-impedance (Hi-Z) state and `FAULT` being asserted low. `OTSD` is latched in this case and `RESET_AB` and `RESET_CD` must be asserted low to clear the latch.

Undervoltage Protection (UVP) and Power-On Reset (POR)

The UVP and POR circuits of the DRV8412/22/32 fully protect the device in any power-up/down and brownout situation. While powering up, the POR circuit resets the overcurrent circuit and ensures that all circuits are fully operational when the `GVDD_X` and `VDD` supply voltages reach 9.8 V (typical). Although `GVDD_X` and `VDD` are independently monitored, a supply voltage drop below the UVP threshold on any `VDD` or `GVDD_X` pin results in all half-bridge outputs immediately being set in the high-impedance (Hi-Z) state and `FAULT` being asserted low. The device automatically resumes operation when all supply voltage on the bootstrap capacitors have increased above the UVP threshold.

DEVICE RESET

Two reset pins are provided for independent control of half-bridges A/B and C/D. When `RESET_AB` is asserted low, all four power-stage FETs in half-bridges A and B are forced into a high-impedance (Hi-Z) state. Likewise, asserting `RESET_CD` low forces all four power-stage FETs in half-bridges C and D into a high-impedance state. To accommodate bootstrap charging prior to switching start, asserting the reset inputs low enables weak pulldown of the half-bridge outputs.

A rising-edge transition on reset input allows the device to resume operation after a shut-down fault. E.g., when either or both half-bridge A and B have OC shutdown, a low to high transition of `RESET_AB` pin will clear the fault and `FAULT` pin; when either or both half-bridge C and D have OC shutdown, a low to high transition of `RESET_CD` pin will clear the fault and `FAULT` pin as well. When an `OTSD` or `GVDD` undervoltage occurs, both `RESET_AB` and `RESET_CD` need to have a low to high transition to clear the fault and `FAULT` signal.

DIFFERENT OPERATIONAL MODES

The DRV8412/22/32 support four different modes of operation:

1. Dual full bridges (FB) (two PWM inputs each full bridge) or four half bridges (HB) with CBC current limit
2. Dual full bridges (two PWM inputs each full bridge) or four half bridges with OC latching shutdown (no CBC current limit)
3. Parallel full bridge (PFB) with CBC current limit
4. Dual full bridges (one PWM input each full bridge) with CBC current limit

In mode 1 and 2, PWM_A controls half bridge A, PWM_B controls half bridge B, etc. [Figure 8](#) shows an application example for full bridge mode operation.

In parallel full bridge mode (mode 3), PWM_A controls both half bridges A and B, and PWM_B controls both half bridges C and D, while PWM_C and PWM_D pins are not used (recommended to connect to ground). Bridges A and B are synchronized internally (even during CBC), and so are bridges C and D. OUT_A and OUT_B should be connected together and OUT_C and OUT_D should be connected together after the output inductor or ferrite bead. [Figure 9](#) shows an example of parallel full bridge mode connection.

In mode 4, one PWM signal controls one full bridge to relieve some I/O resource from MCU, i.e., PWM_A controls half bridges A and B and PWM_C controls

half bridges C and D. In this mode, the operation of half bridge B is complementary to half bridge A, and the operation of half bridge D is complementary to half bridge C. For example, when PWM_A is high, high side FET in half bridge A and low side FET in half bridge B will be on and low side FET in half bridge A and high side FET in half bridge B will be off. Since PWM_B and PWM_D pins are not used in this mode, it is recommended to connect them to ground.

Because each half bridge has independent supply and ground pins, a shunt sensing resistor can be inserted between PVDD to PVDD_X or GND_X to GND (ground plane). A high side shunt resistor between PVDD and PVDD_X is recommended for differential current sensing because a high bias voltage on the low side sensing could affect device operation. If low side sensing has to be used, a shunt resistor value of 10 mΩ or less or sense voltage 100 mV or less is recommended.

The DRV8412/22/32 can be used for stepper motor applications as illustrated in [Figure 10](#); they can be also used in three phase permanent magnet synchronous motor (PMSM) and sinewave brushless DC motor applications. [Figure 11](#) and [Figure 12](#) show the three-phase application example with different current sense locations.

[Figure 13](#) shows an example of a TEC driver application. Same configuration can also be used for DC output applications.

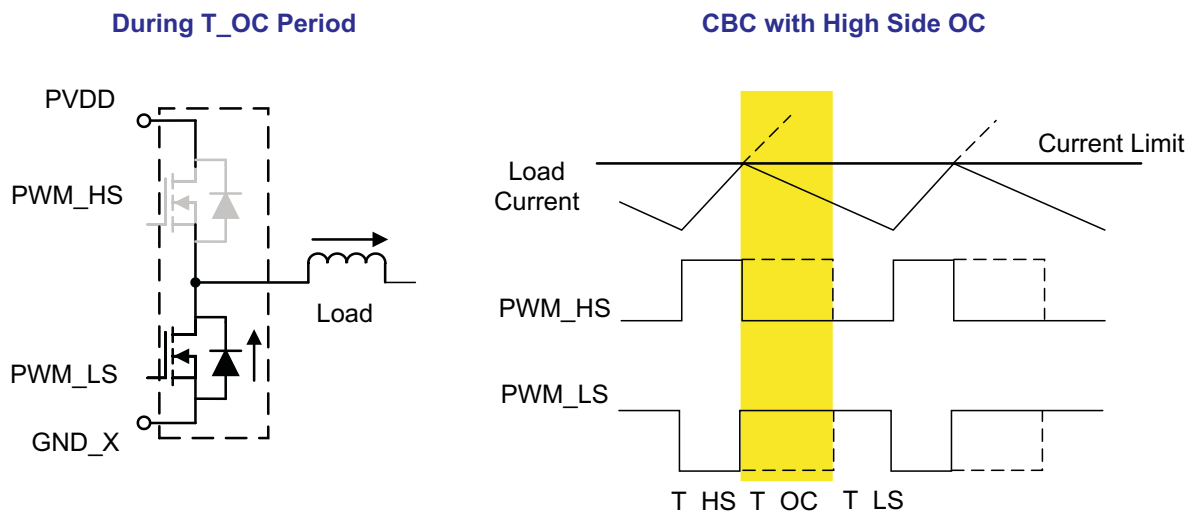

Figure 6. Cycle-by-Cycle Operation with High Side OC (dashed line: normal operation; solid line: CBC event)

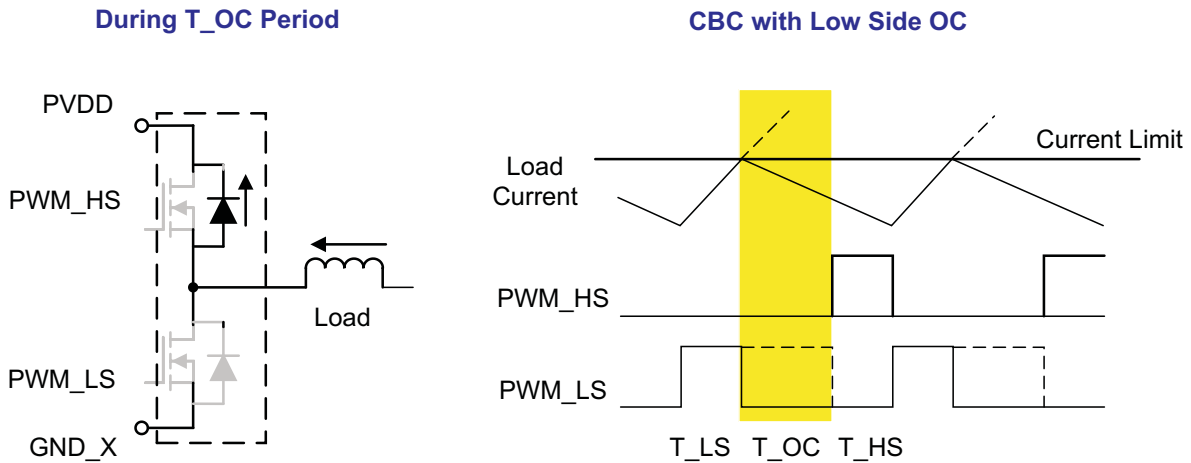

Figure 7. Cycle-by-Cycle Operation with Low Side OC (dashed line: normal operation; solid line: CBC event)

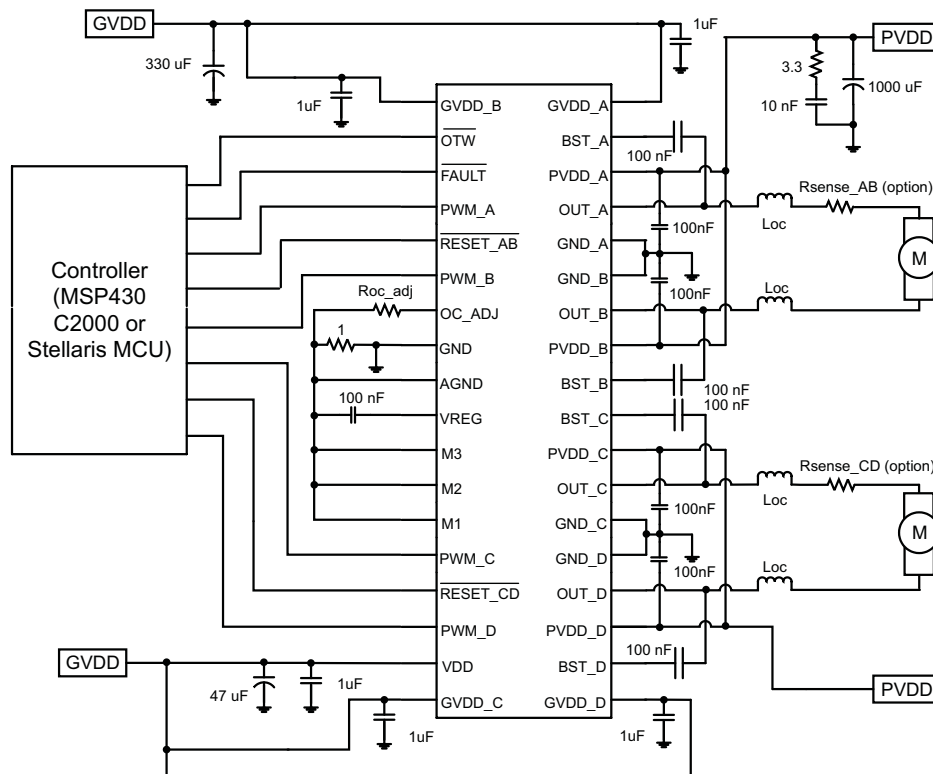
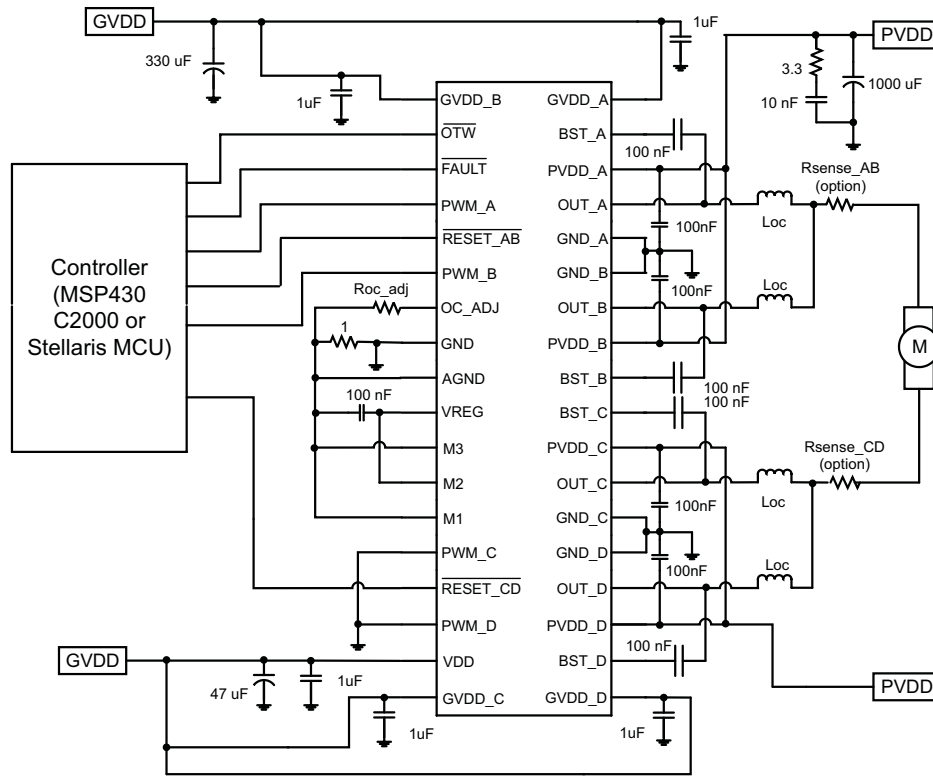

Figure 8. Application Diagram Example for Full Bridge Mode Operation



PWM_A controls OUT_A and OUT_B; PWM_B controls OUT_C and OUT_D.

Figure 9. Application Diagram Example for Parallel Full Bridge Mode Operation

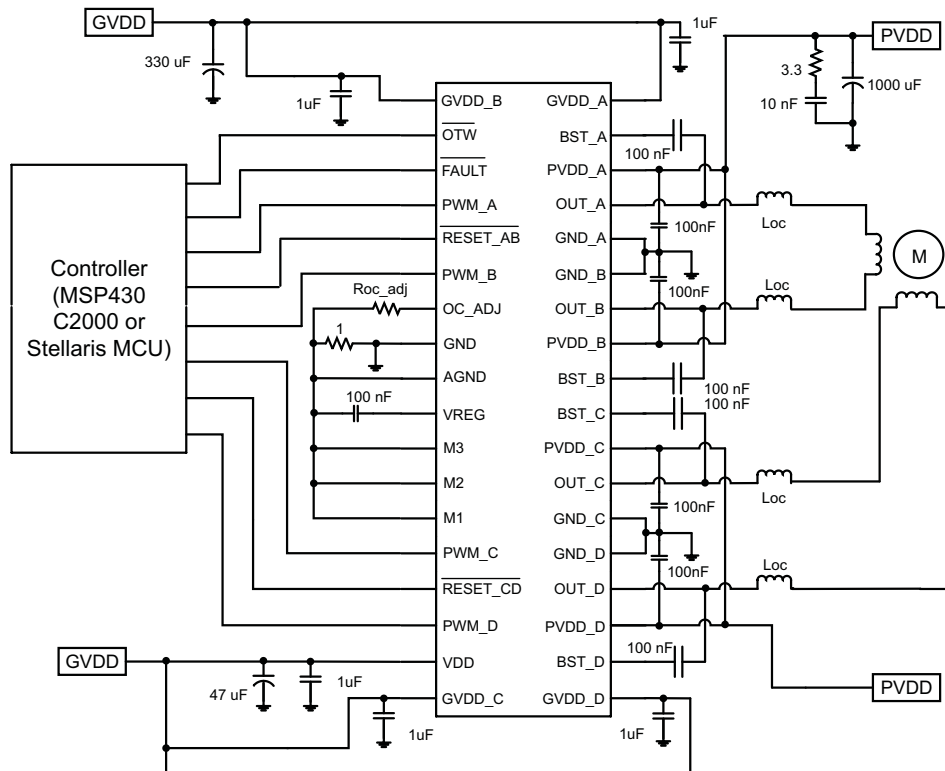

Figure 10. Application Diagram Example for Stepper Motor Operation

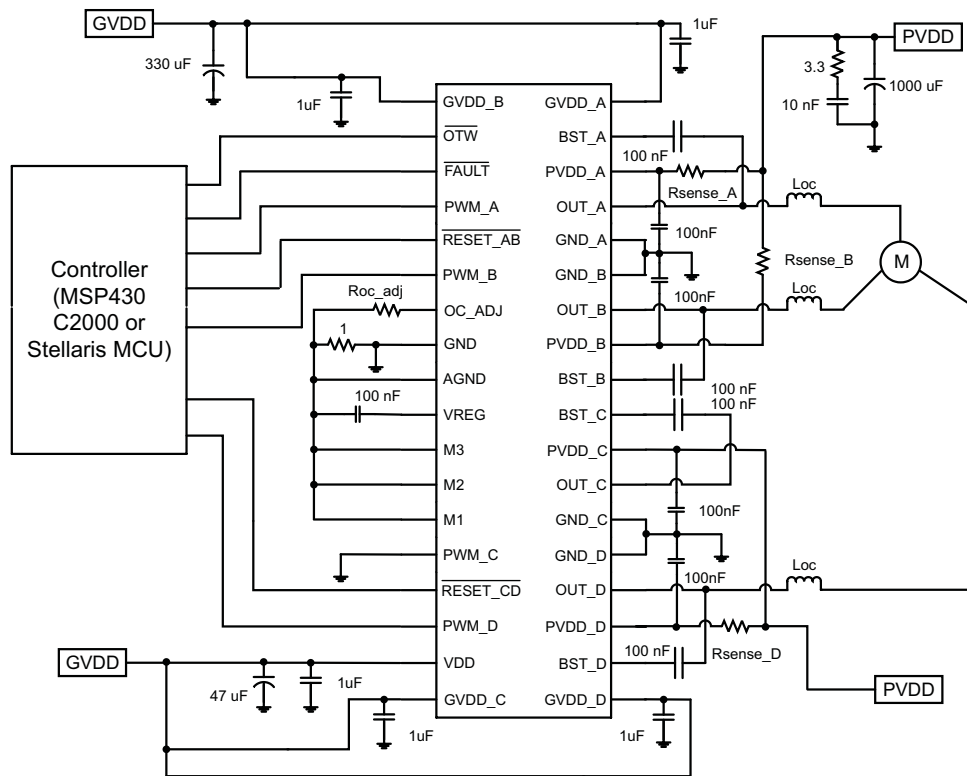

Figure 11. Application Diagram Example for Three Phase PMSM PVDD Sense Operation

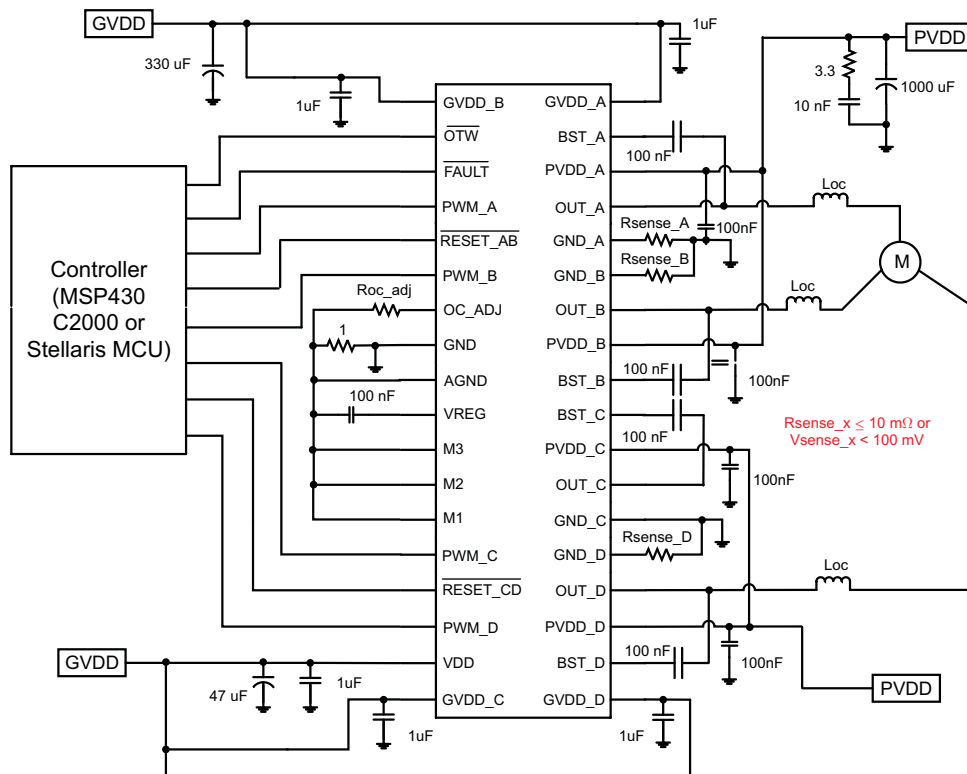

Figure 12. Application Diagram Example for Three Phase PMSM GND Sense Operation

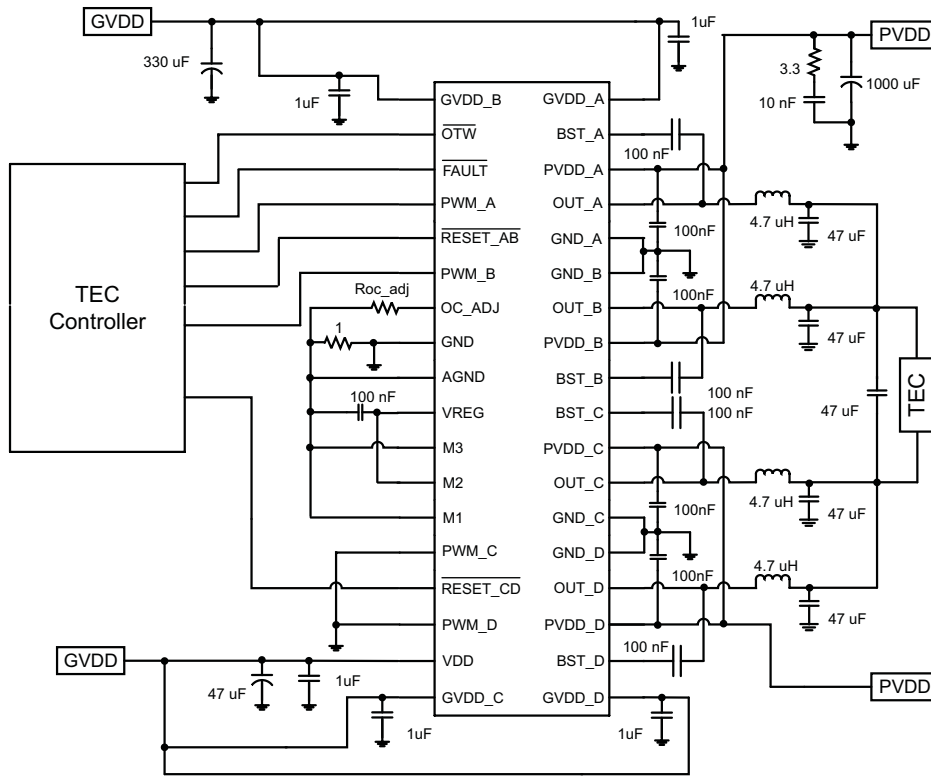

Figure 13. Application Diagram Example for TEC Driver

APPLICATION INFORMATION

SYSTEM DESIGN RECOMMENDATIONS

Voltage of Decoupling Capacitor

The voltage of the decoupling capacitors should be selected in accordance with good design practices. Temperature, ripple current, and voltage overshoot must be considered. The high frequency decoupling capacitor should use ceramic capacitor with X5R or better rating. For a 50-V application, a minimum voltage rating of 63 V is recommended.

VREG Pin

The VREG pin is used for internal logic and not recommended to be used as a voltage source for external circuitry.

VDD Pin

The transient current in VDD pin could be significantly higher than average current through that pin. A low resistive path to GVDD should be used. A 22- μ F to 47- μ F capacitor should be placed on VDD pin beside the 100-nF to 1- μ F decoupling capacitor to provide a constant voltage during transient.

OTW Pin

\overline{OTW} reporting indicates the device approaching high junction temperature. This signal can be used with MCU to decrease system power when \overline{OTW} is low in order to prevent OT shut down at a higher temperature.

Mode Select Pin

Mode select pins (M1, M2, and M3) should be connected to either VREG (for logic high) or AGND for logic low. It is not recommended to connect mode pins to board ground if 1- Ω resistor is used between AGND and GND.

Output Inductor Selection

For normal operation, inductance in motor (assume larger than 10 μ H) is sufficient to provide low di/dt output (e.g. for EMI) and proper protection during overload condition (CBC current limiting feature). So no additional output inductors are needed during normal operation.

However during a short condition, the motor (or other load) is shorted, so the load inductance is not present in the system anymore; the current in the device can reach such a high level that may exceed the abs max current rating due to extremely low impedance in the short circuit path and high di/dt before oc detection circuit kicks in. So a ferrite bead or inductor is recommended to utilize the short circuit protection feature in DRV8412/22/32. With an external inductance or ferrite bead, the current will rise at a much slower rate and reach a lower current level before oc protection starts. The device will then either operate CBC current limit or OC shut down automatically (when current is well above the current limit threshold) to protect the system.

For a system that has limited space, a power ferrite bead can be used instead of an inductor. The current rating of ferrite bead has to be higher than the RMS current of the system at normal operation. A ferrite bead designed for very high frequency is NOT recommended. A minimum impedance of 10 Ω or higher is recommended at 10 MHz or lower frequency to effectively limit the current rising rate during short circuit condition.

The TDK MPZ2012S300A and MPZ2012S101A (with size of 0805 inch type) have been tested in our system to meet a short circuit condition in the DRV8412. But other ferrite beads that have similar frequency characteristics can be used as well.

For higher power applications, such as in the DRV8422 and DRV8432, there might be limited options to select suitable ferrite bead with high current rating. If an adequate ferrite bead cannot be found, an inductor can be used.

The inductance can be calculated as:

$$L_{oc_min} = \frac{PVDD \cdot T_{oc_delay}}{I_{peak} - I_{ave}} \quad (1)$$

Where $T_{oc_delay} = 250$ nS, $I_{peak} = 15$ A (below abs max rating).

Because an inductor usually saturates pretty quickly after reaching its current rating, it is recommended to use an inductor with a doubled value or an inductor with a current rating well above the operating condition.

Parallel Mode Operation

For a device operated in parallel mode, a minimum of 30 nH to 100 nH inductance or a ferrite bead is required after the output pins (e.g. OUT_A and OUT_B) before connecting the two channels together. This will help to prevent any shoot through between two paralleled channels during switching transient due to mismatch of paralleled channels (e.g., processor variation, unsymmetrical PCB layout, etc).

TEC Driver Application

For TEC driver or other non-motor related applications (e.g. resistive load or dc output), a low-pass LC filter can be used to meet the requirement.

PCB LAYOUT RECOMMENDATION

PCB Material Recommendation

FR-4 Glass Epoxy material with 2 oz. copper on both top and bottom layer is recommended for improved thermal performance (better heat sinking) and less noise susceptibility (lower PCB trace inductance).

Ground Plane

Because of the power level of these devices, it is recommended to use a big unbroken single ground plane for the whole system / board. The ground plane can be easily made at bottom PCB layer. In order to minimize the impedance and inductance of ground traces, the traces from ground pins should keep as short and wide as possible before connected to bottom ground plane through vias. Multiple vias are suggested to reduce the impedance of vias. Try to clear the space around the device as much as possible especially at bottom PCB side to improve the heat spreading.

Decoupling Capacitor

High frequency decoupling capacitors (100 nF) on PVDD_X pins should be placed close to these pins and with a short ground return path to minimize the inductance on the PCB trace.

AGND

AGND is a localized internal ground for logic signals. A 1-Ω resistor is recommended to be connected between GND and AGND to isolate the noise from board ground to AGND. There are other two components are connected to this local ground: 0.1-μF capacitor between VREG to AGND and Roc_adj resistor between OC_ADJ and AGND. Capacitor for VREG should be placed close to VREG and AGND pin and connected without vias.

Current Shunt Resistor

If current shunt resistor is connected between GND_X to GND or PVDD_X to PVDD, make sure there is only one single path to connect each GND_X or PVDD_X pin to shunt resistor, and the path is short and symmetrical on each sense path to minimize the measurement error due to additional resistance on the trace.

PCB LAYOUT EXAMPLE

An example of the schematic and PCB layout of DRV8412 are shown in [Figure 14](#), [Figure 15](#), and [Figure 16](#).

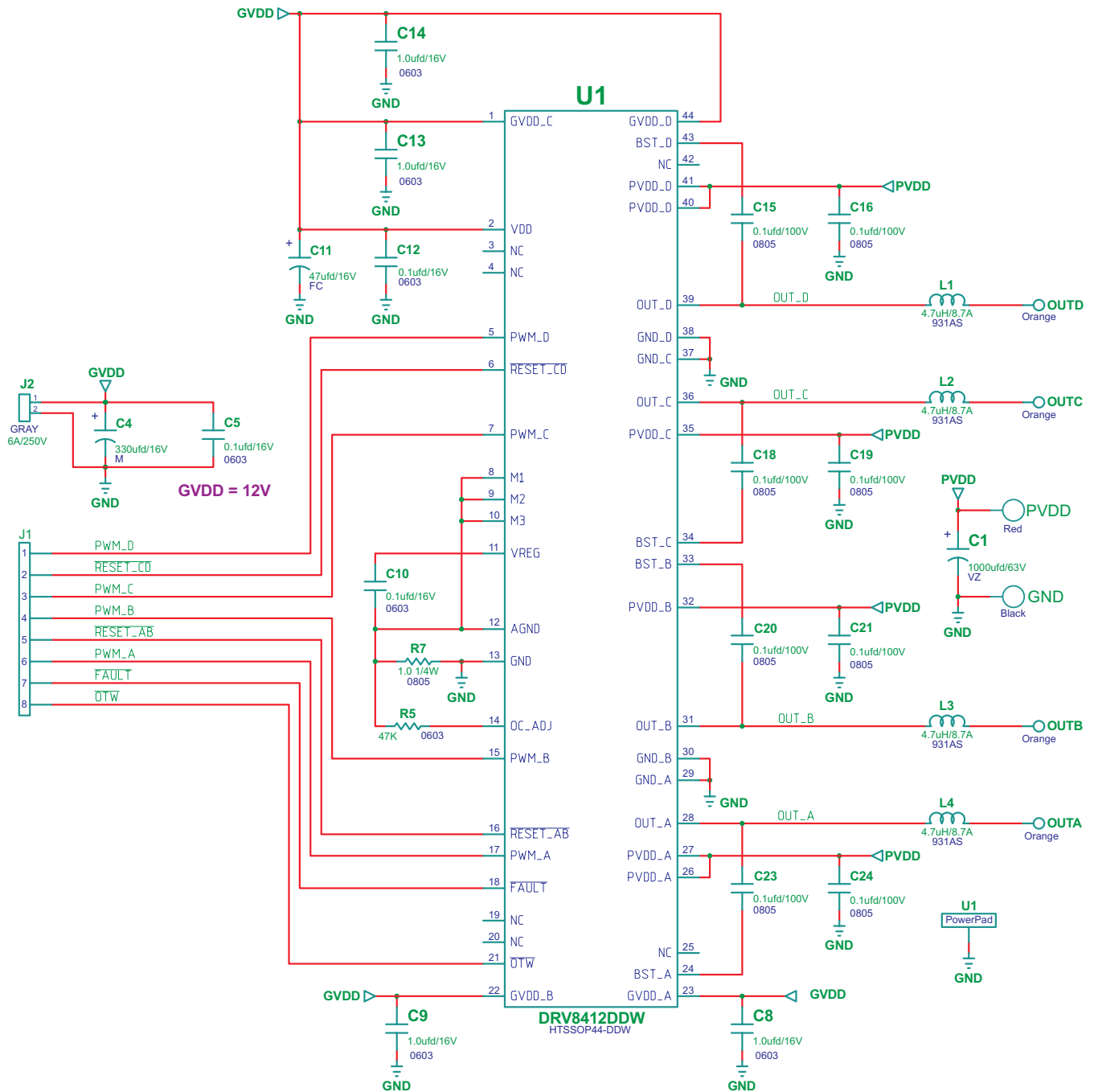
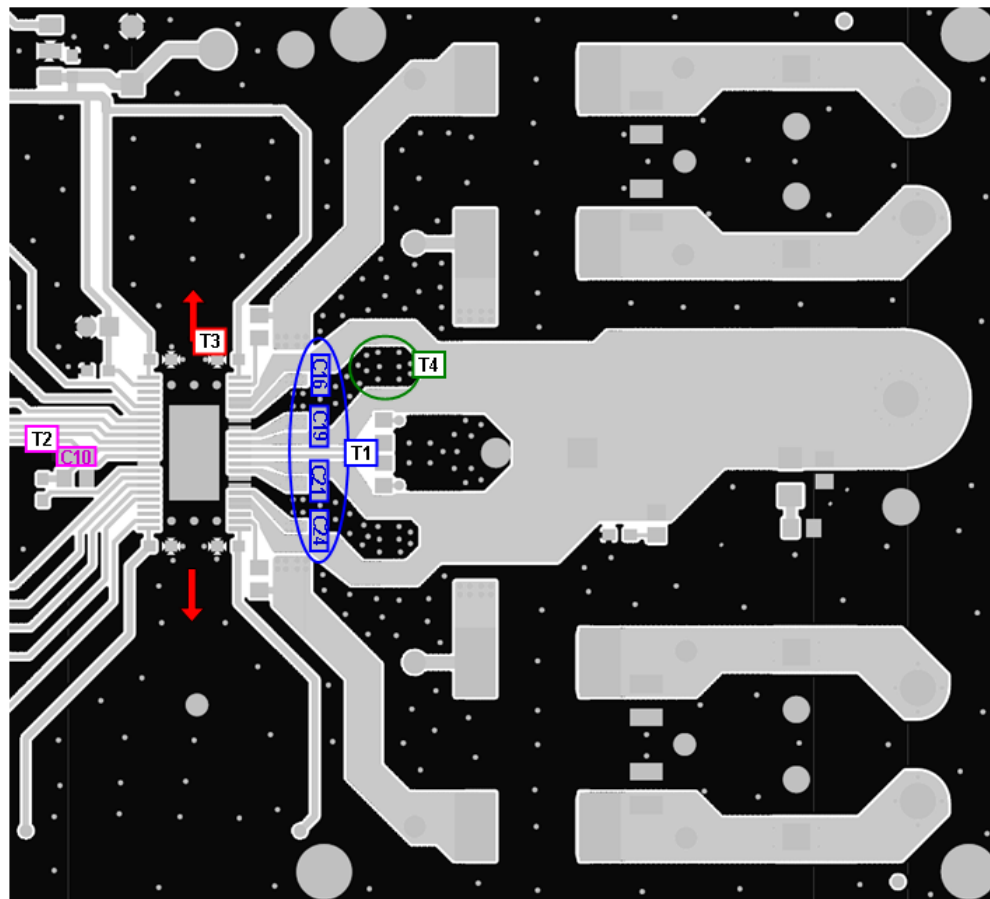

Figure 14. DRV8412 Schematic Example



T1: PVDD decoupling capacitors C16, C19, C21, and C24 should be placed very close to PVDD_X pins and ground return path.

T2: VREG decoupling capacitor C10 should be placed very close to VREG and AGND pins.

T3: Clear the space above and below the device as much as possible to improve the thermal spreading.

T4: Add many vias to reduce the impedance of ground path through top to bottom side. Make traces as wide as possible for ground path such as GND_X path.

Figure 15. Printed Circuit Board – Top Layer

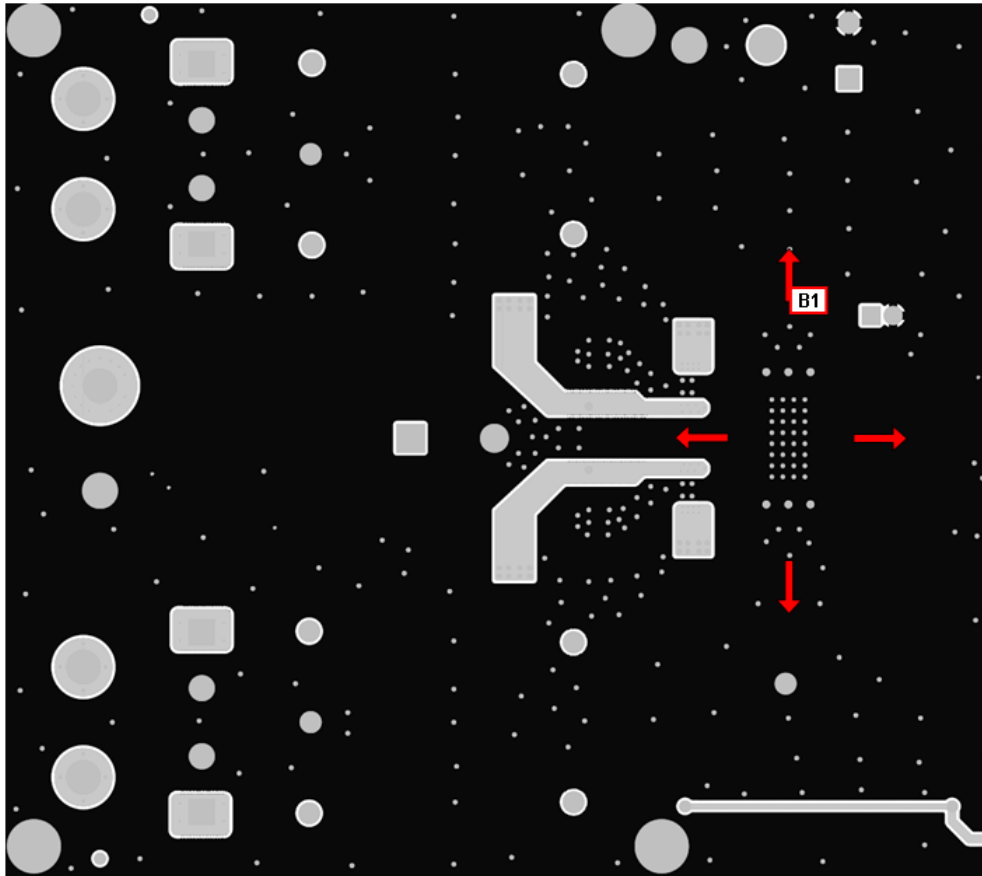

B1: Do not block the heat transfer path at bottom side. Clear as much space as possible for better heat spreading.

Figure 16. Printed Circuit Board – Bottom Layer

THERMAL INFORMATION

The thermally enhanced package provided with the DRV8422/32 is designed to interface directly to heat sink using a thermal interface compound, (e.g., Ceramique from Arctic Silver, TIMTronics 413, etc.). The heat sink then absorbs heat from the ICs and couples it to the local air. It is also a good practice to connect the heatsink to system ground on the PCB board to reduce the ground noise.

$R_{\theta JA}$ is a system thermal resistance from junction to ambient air. As such, it is a system parameter with the following components:

- $R_{\theta JC}$ (the thermal resistance from junction to case, or in this example the power pad or heat slug)
- Thermal grease thermal resistance
- Heat sink thermal resistance

The thermal grease thermal resistance can be calculated from the exposed power pad or heat slug area and the thermal grease manufacturer's area thermal resistance (expressed in °C-in²/W or °C-mm²/W). The approximate exposed heat slug size is as follows:

- DRV8422, 44-pin TSSOP 0.053 in² (34 mm²)
- DRV8432, 36-pin PSOP3 0.124 in² (80 mm²)

The thermal resistance of thermal pads is considered higher than a thin thermal grease layer and is not recommended. Thermal tape has an even higher thermal resistance and should not be used at all. Heat sink thermal resistance is predicted by the heat sink vendor, modeled using a continuous flow dynamics (CFD) model, or measured.

Thus the system $R_{\theta JA} = R_{\theta JC} + \text{thermal grease resistance} + \text{heat sink resistance}$.

See the TI application report, *IC Package Thermal Metrics* (SPRA953A), for more thermal information.

DRV8412 Thermal Via Design Recommendation

Thermal pad of the DRV8412 is attached at bottom of device to improve the thermal capability of the device. The thermal pad has to be soldered with a very good coverage on PCB in order to deliver the power specified in the datasheet. The figure below shows the recommended thermal via and land pattern design for the DRV8412. For additional information, see TI application report, *PowerPad Made Easy* (SLMA004B) and *PowerPad Layout Guidelines* (SOLA120).

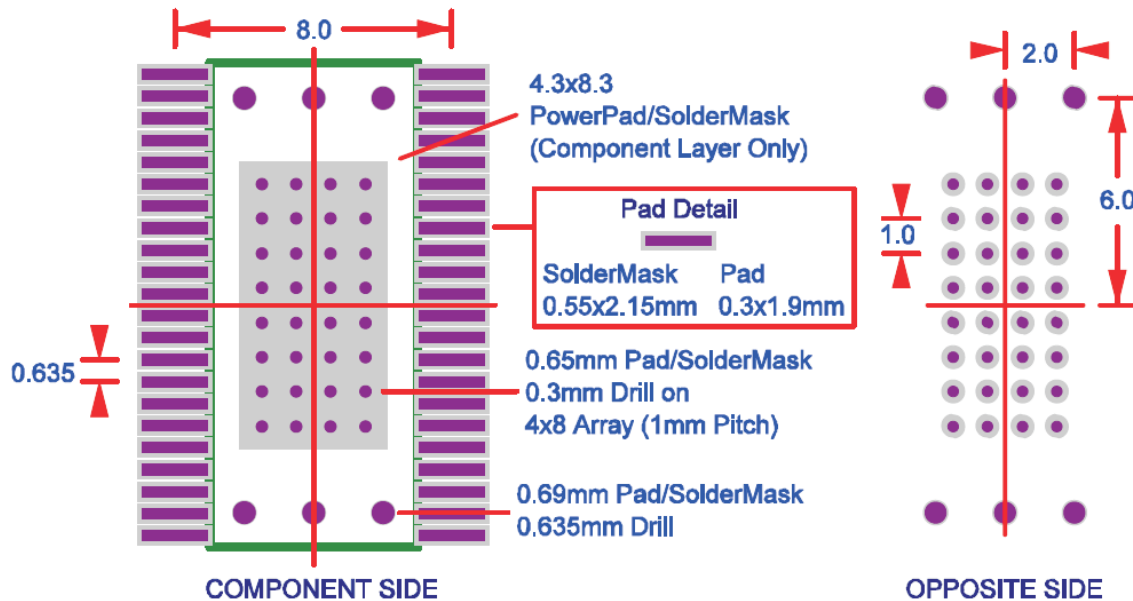

Figure 17. DRV8412 Thermal Via Footprint

PACKAGING INFORMATION

Orderable Device	Status ⁽¹⁾	Package Type	Package Drawing	Pins	Package Qty	Eco Plan ⁽²⁾	Lead/Ball Finish	MSL Peak Temp ⁽³⁾
DRV8412DDW	ACTIVE	HTSSOP	DDW	44	35	Green (RoHS & no Sb/Br)	CU NIPDAU	Level-3-260C-168 HR
DRV8412DDWR	ACTIVE	HTSSOP	DDW	44	2000	Green (RoHS & no Sb/Br)	CU NIPDAU	Level-3-260C-168 HR
DRV8422DDV	PREVIEW	HTSSOP	DDV	44	35	TBD	Call TI	Call TI
DRV8422DDVR	PREVIEW	HTSSOP	DDV	44	2000	TBD	Call TI	Call TI

⁽¹⁾ The marketing status values are defined as follows:

ACTIVE: Product device recommended for new designs.

LIFEBUY: TI has announced that the device will be discontinued, and a lifetime-buy period is in effect.

NRND: Not recommended for new designs. Device is in production to support existing customers, but TI does not recommend using this part in a new design.

PREVIEW: Device has been announced but is not in production. Samples may or may not be available.

OBSOLETE: TI has discontinued the production of the device.

⁽²⁾ Eco Plan - The planned eco-friendly classification: Pb-Free (RoHS), Pb-Free (RoHS Exempt), or Green (RoHS & no Sb/Br) - please check <http://www.ti.com/productcontent> for the latest availability information and additional product content details.

TBD: The Pb-Free/Green conversion plan has not been defined.

Pb-Free (RoHS): TI's terms "Lead-Free" or "Pb-Free" mean semiconductor products that are compatible with the current RoHS requirements for all 6 substances, including the requirement that lead not exceed 0.1% by weight in homogeneous materials. Where designed to be soldered at high temperatures, TI Pb-Free products are suitable for use in specified lead-free processes.

Pb-Free (RoHS Exempt): This component has a RoHS exemption for either 1) lead-based flip-chip solder bumps used between the die and package, or 2) lead-based die adhesive used between the die and leadframe. The component is otherwise considered Pb-Free (RoHS compatible) as defined above.

Green (RoHS & no Sb/Br): TI defines "Green" to mean Pb-Free (RoHS compatible), and free of Bromine (Br) and Antimony (Sb) based flame retardants (Br or Sb do not exceed 0.1% by weight in homogeneous material)

⁽³⁾ MSL, Peak Temp. -- The Moisture Sensitivity Level rating according to the JEDEC industry standard classifications, and peak solder temperature.

Important Information and Disclaimer:The information provided on this page represents TI's knowledge and belief as of the date that it is provided. TI bases its knowledge and belief on information provided by third parties, and makes no representation or warranty as to the accuracy of such information. Efforts are underway to better integrate information from third parties. TI has taken and continues to take reasonable steps to provide representative and accurate information but may not have conducted destructive testing or chemical analysis on incoming materials and chemicals. TI and TI suppliers consider certain information to be proprietary, and thus CAS numbers and other limited information may not be available for release.

In no event shall TI's liability arising out of such information exceed the total purchase price of the TI part(s) at issue in this document sold by TI to Customer on an annual basis.

MECHANICAL DATA

DDW (R-PDSO-G44)

PowerPAD™ PLASTIC SMALL-OUTLINE PACKAGE (PAD DOWN)

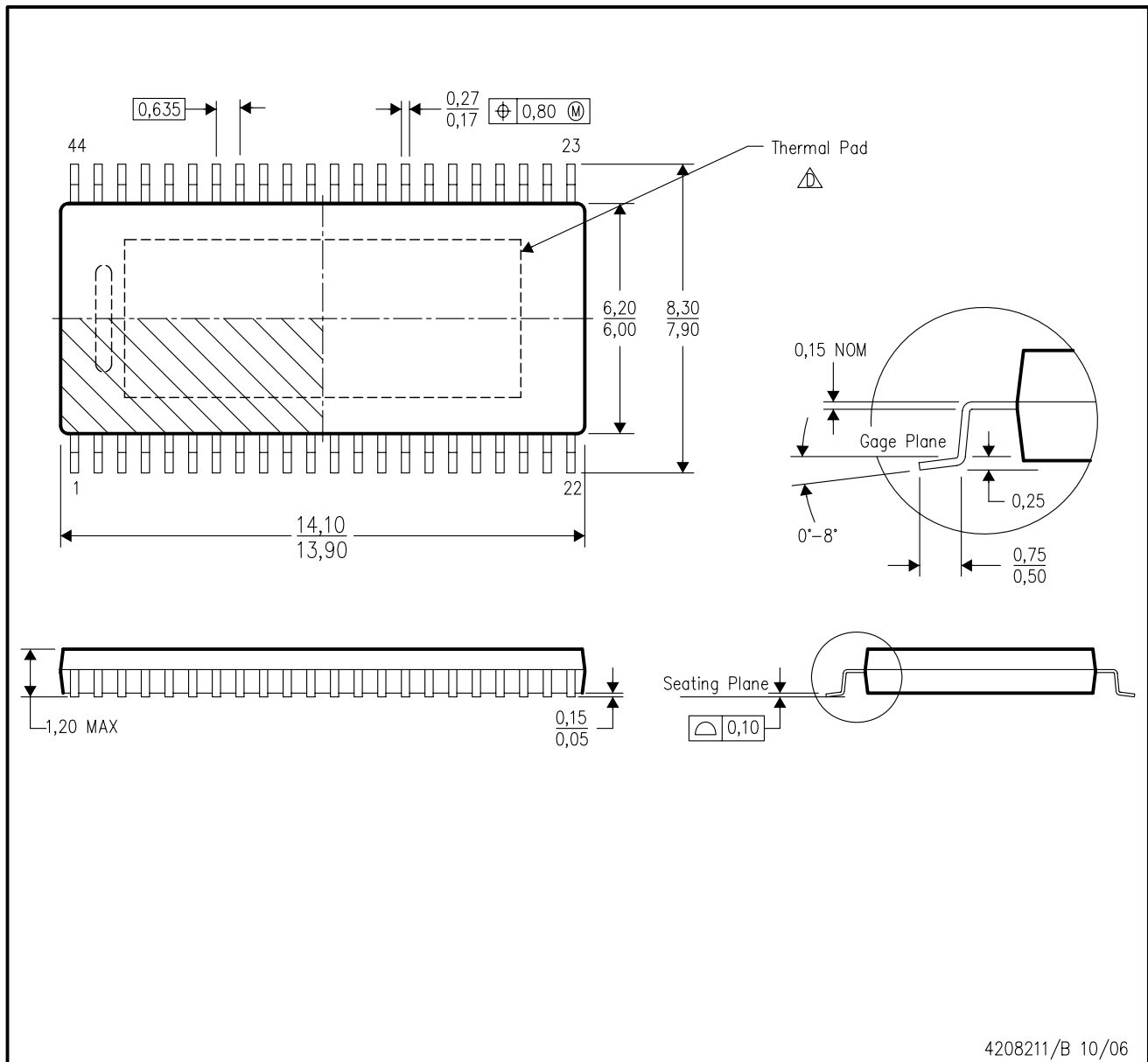

4208211/B 10/06

- NOTES:
- A. All linear dimensions are in millimeters.
 - B. This drawing is subject to change without notice.
 - C. Body dimensions do not include mold flash or protrusion not to exceed 0,15.
 - △ This package thermal performance is optimized for conductive cooling with attachment to an external heat sink. See the product data sheet for details regarding the exposed thermal pad dimensions.

PowerPAD is a trademark of Texas Instruments.

THERMAL INFORMATION

This PowerPAD™ package incorporates an exposed thermal pad that is designed to be attached to a printed circuit board (PCB). The thermal pad must be soldered directly to the PCB. After soldering, the PCB can be used as a heatsink. In addition, through the use of thermal vias, the thermal pad can be attached directly to the appropriate copper plane shown in the electrical schematic for the device, or alternatively, can be attached to a special heatsink structure designed into the PCB. This design optimizes the heat transfer from the integrated circuit (IC).

For additional information on the PowerPAD package and how to take advantage of its heat dissipating abilities, refer to Technical Brief, PowerPAD Thermally Enhanced Package, Texas Instruments Literature No. SLMA002 and Application Brief, PowerPAD Made Easy, Texas Instruments Literature No. SLMA004. Both documents are available at www.ti.com.

The exposed thermal pad dimensions for this package are shown in the following illustration.

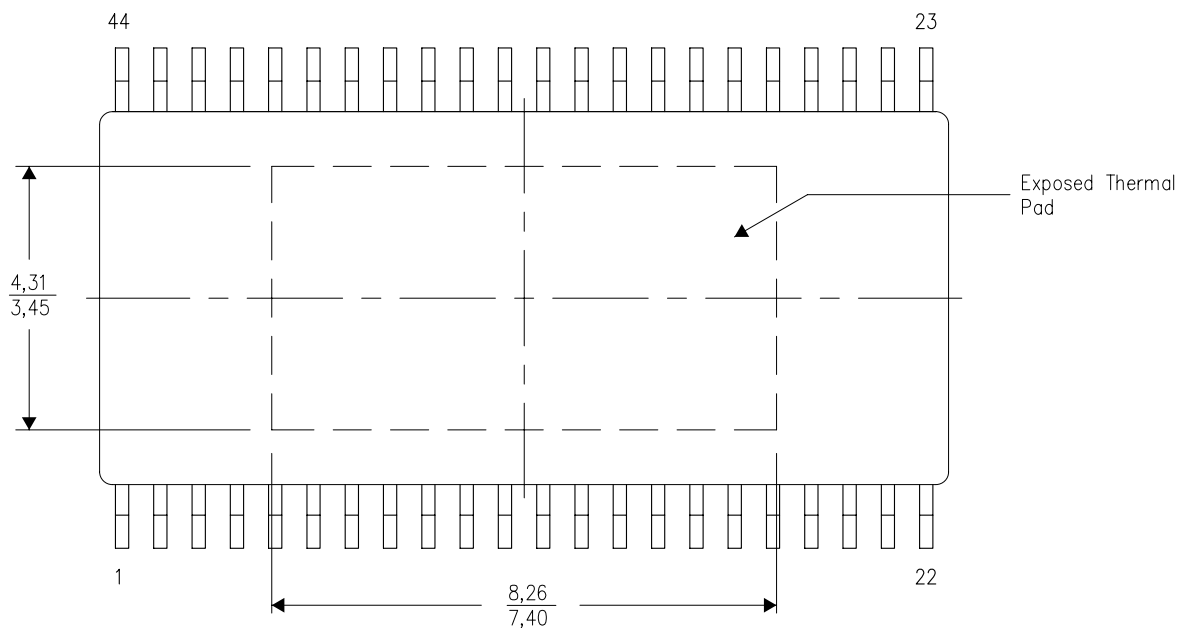

Top View

NOTE: All linear dimensions are in millimeters

Exposed Thermal Pad Dimensions

MECHANICAL DATA

DDV (R-PDSO-G44)

PowerPAD™ PLASTIC SMALL-OUTLINE PACKAGE (DIE DOWN)

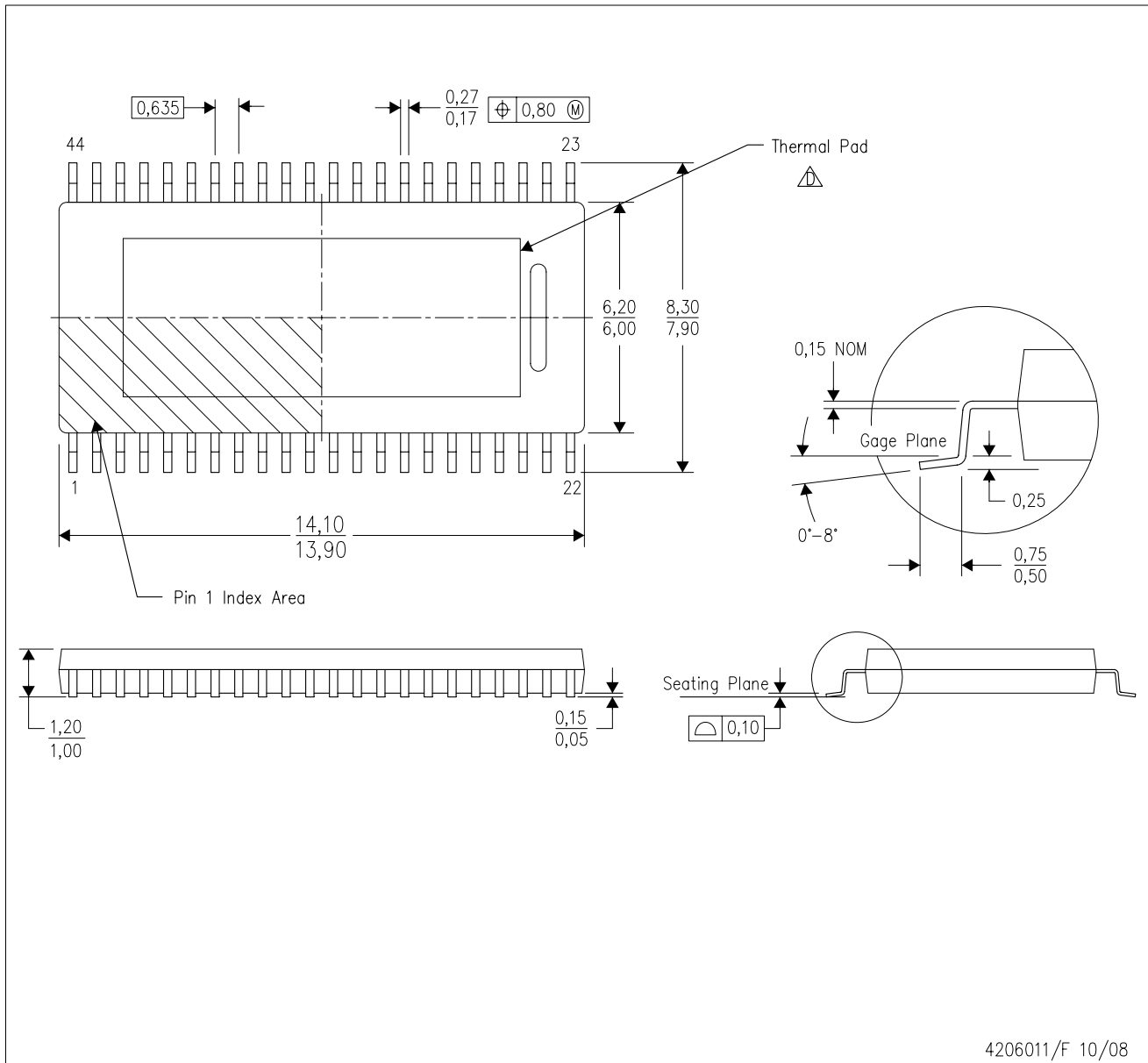

4206011/F 10/08

- NOTES:
- A. All linear dimensions are in millimeters. Dimensioning and tolerancing per ASME Y14.5M-1994.
 - B. This drawing is subject to change without notice.
 - C. Body dimensions do not include mold flash or protrusion not to exceed 0,15.
- △ This package is designed to be attached directly to an external heatsink. Refer to Technical Brief, PowerPad Thermally Enhanced Package, Texas Instruments Literature No. SLMA002 for information regarding recommended board layout. This document is available at www.ti.com <<http://www.ti.com>>. See the product data sheet for details regarding the exposed thermal pad dimensions.

PowerPAD is a trademark of Texas Instruments.

IMPORTANT NOTICE

Texas Instruments Incorporated and its subsidiaries (TI) reserve the right to make corrections, modifications, enhancements, improvements, and other changes to its products and services at any time and to discontinue any product or service without notice. Customers should obtain the latest relevant information before placing orders and should verify that such information is current and complete. All products are sold subject to TI's terms and conditions of sale supplied at the time of order acknowledgment.

TI warrants performance of its hardware products to the specifications applicable at the time of sale in accordance with TI's standard warranty. Testing and other quality control techniques are used to the extent TI deems necessary to support this warranty. Except where mandated by government requirements, testing of all parameters of each product is not necessarily performed.

TI assumes no liability for applications assistance or customer product design. Customers are responsible for their products and applications using TI components. To minimize the risks associated with customer products and applications, customers should provide adequate design and operating safeguards.

TI does not warrant or represent that any license, either express or implied, is granted under any TI patent right, copyright, mask work right, or other TI intellectual property right relating to any combination, machine, or process in which TI products or services are used. Information published by TI regarding third-party products or services does not constitute a license from TI to use such products or services or a warranty or endorsement thereof. Use of such information may require a license from a third party under the patents or other intellectual property of the third party, or a license from TI under the patents or other intellectual property of TI.

Reproduction of TI information in TI data books or data sheets is permissible only if reproduction is without alteration and is accompanied by all associated warranties, conditions, limitations, and notices. Reproduction of this information with alteration is an unfair and deceptive business practice. TI is not responsible or liable for such altered documentation. Information of third parties may be subject to additional restrictions.

Resale of TI products or services with statements different from or beyond the parameters stated by TI for that product or service voids all express and any implied warranties for the associated TI product or service and is an unfair and deceptive business practice. TI is not responsible or liable for any such statements.

TI products are not authorized for use in safety-critical applications (such as life support) where a failure of the TI product would reasonably be expected to cause severe personal injury or death, unless officers of the parties have executed an agreement specifically governing such use. Buyers represent that they have all necessary expertise in the safety and regulatory ramifications of their applications, and acknowledge and agree that they are solely responsible for all legal, regulatory and safety-related requirements concerning their products and any use of TI products in such safety-critical applications, notwithstanding any applications-related information or support that may be provided by TI. Further, Buyers must fully indemnify TI and its representatives against any damages arising out of the use of TI products in such safety-critical applications.

TI products are neither designed nor intended for use in military/aerospace applications or environments unless the TI products are specifically designated by TI as military-grade or "enhanced plastic." Only products designated by TI as military-grade meet military specifications. Buyers acknowledge and agree that any such use of TI products which TI has not designated as military-grade is solely at the Buyer's risk, and that they are solely responsible for compliance with all legal and regulatory requirements in connection with such use.

TI products are neither designed nor intended for use in automotive applications or environments unless the specific TI products are designated by TI as compliant with ISO/TS 16949 requirements. Buyers acknowledge and agree that, if they use any non-designated products in automotive applications, TI will not be responsible for any failure to meet such requirements.

Following are URLs where you can obtain information on other Texas Instruments products and application solutions:

Products

Amplifiers	amplifier.ti.com
Data Converters	dataconverter.ti.com
DLP® Products	www.dlp.com
DSP	dsp.ti.com
Clocks and Timers	www.ti.com/clocks
Interface	interface.ti.com
Logic	logic.ti.com
Power Mgmt	power.ti.com
Microcontrollers	microcontroller.ti.com
RFID	www.ti-rfid.com
RF/IF and ZigBee® Solutions	www.ti.com/lprf

Applications

Audio	www.ti.com/audio
Automotive	www.ti.com/automotive
Broadband	www.ti.com/broadband
Digital Control	www.ti.com/digitalcontrol
Medical	www.ti.com/medical
Military	www.ti.com/military
Optical Networking	www.ti.com/opticalnetwork
Security	www.ti.com/security
Telephony	www.ti.com/telephony
Video & Imaging	www.ti.com/video
Wireless	www.ti.com/wireless

Mailing Address: Texas Instruments, Post Office Box 655303, Dallas, Texas 75265
Copyright © 2009, Texas Instruments Incorporated